

Cable Trolleys for C-Rails

Program 0250 | 0255 | 0260



CONDUCTIX
wampfler

Ⓞ DELACHAUX GROUP

Contents

C-Rail and Accessories Program 0250

C-Rail 50 x 50.....	4
Track Coupler	4
End Stops.....	4
Track Support Brackets.....	4
Support Arm and Girder Clip.....	5
Brackets.....	5

Cable Trolleys Program 0250

Cable Trolleys for Flat Cables.....	6
Cable Trolleys for Round Cables	7
Pairs of Rollers for Cable Trolleys.....	7

C-Rail and Accessories Program 0255

C-Rail 63 x 63.....	8
Track Coupler	8
End Stops.....	8
Track Support Brackets.....	8
Support Arm and Girder Clip.....	9
Brackets.....	9

Cable Trolleys Program 0255

Cable Trolleys for Flat Cables.....	10
Cable Trolleys for Round Cables	11
Pairs of Rollers for Cable Trolleys.....	11

C-Rail and Accessories Program 0260

C-Rail 80 x 80.....	12
Track Coupler	12
End Stop	12
Track Support Bracket.....	12
Brackets.....	13

Cable Trolleys Program 0260

Cable Trolleys for Flat Cables.....	14
Cable Trolleys for Round Cables	15
Pairs of Rollers for Cable Trolleys.....	15

Cable Trolleys Light Version

Cable Trolleys for Flat Cables.....	16
Cable Trolleys for Round Cables	16
Trolleys with 4 Rollers	17
Spring Safety Hook	17
End Stops.....	17

Accessories for Festoon Systems Program 0250, 0255 and 0260

Towing Ropes.....	18
Damping Devices	18
Round Cable Clamps	19
Spacers	19
Flat Cable Organizer	20

Helpful Hints / Spare Parts

Helpful Hints.....	21
Wear Parts	25

C-Rail and Accessories Program 0250

C-Rail 50 x 50

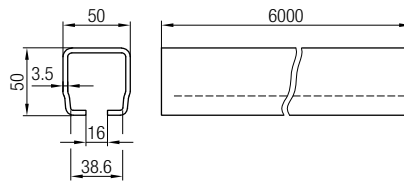

$$I_x = 17.8 \text{ cm}^4; W_x = 6.4 \text{ cm}^3$$

Order No.

025100*

Technical details

- Material: sendzimir galvanized steel
- Weight: 4.36 kg/m
- Standard Length: 6 m

*Standard range

Track Coupler

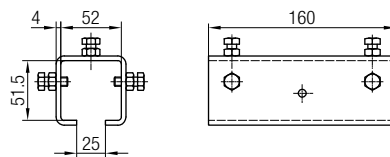

Order No.

025105*

Technical details

- Material: galvanized steel
- Weight: 1.0 kg

*Standard range

End Stops

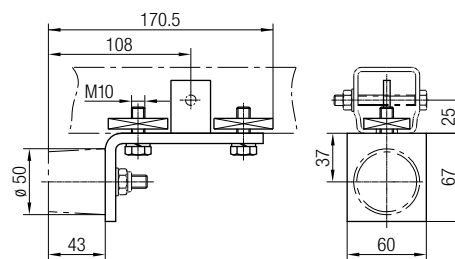

Order No.

025110

without Rubber Buffer

025111*

with Rubber Buffer

Technical details

- Material: galvanized steel
- Weight: 1.0 kg

To avoid system damage we recommend the fitting of a securing bolt as illustrated.

*Standard range

Track Support Brackets

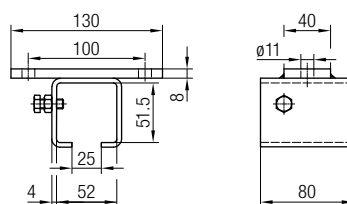

Order No.

025121

Technical details

- Material: galvanized steel
- Perm. Load: 320 kg
- Weight: 0.8 kg

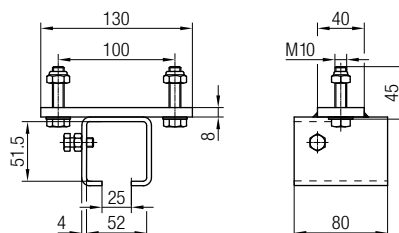

Order No.

025123

Technical details

- Material: galvanized steel
- Perm. Load: 320 kg
- Weight: 0.9 kg

C-Rail and Accessories Program 0250

Track Support Bracket

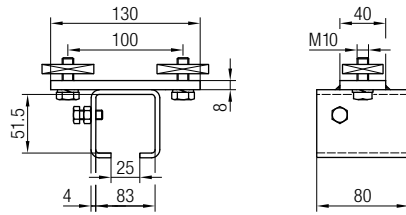

Order No.

025122*

Technical details

- Material: galvanized steel
- Hardware: galvanized steel
- Perm. Load: 320 kg
- Weight: 0.9 kg

*Standard range

Support Arm and Girder Clip

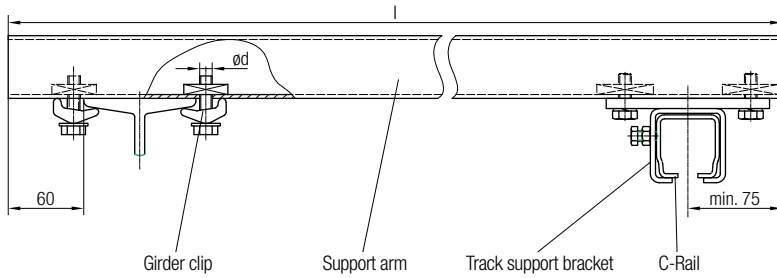

Description	Order No.	l [mm]	Weight [kg]
Support arm	020277-1000*	1000	4.4

Material: sendzimir galvanized steel

Description	Order No.	ø d [mm]	Weight [kg]
Girder clip	020180-12/550*	M12	0.3

Material: galvanized steel

*Standard range

Brackets

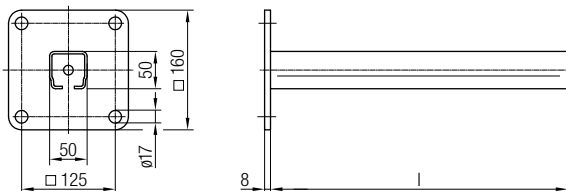

Order No.	l [mm]	Material	Weight [kg]
020191-0500	500	galvanized steel	3.8
020191-0800	800		5.1

Cable Trolleys Program 0250

Cable Trolleys for Flat Cables

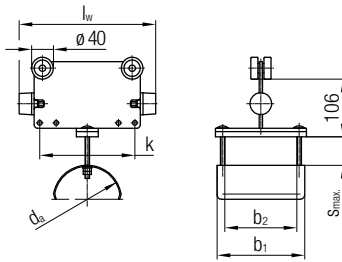

Cable Trolley

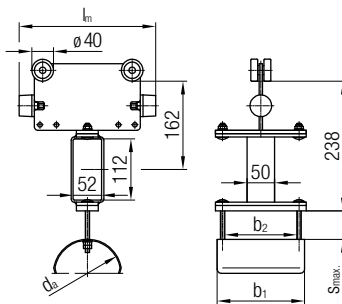

Towing Trolley

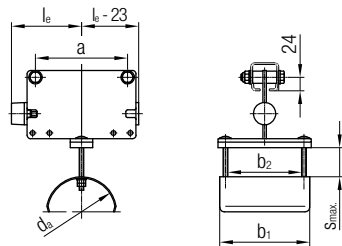

End Clamp¹⁾

Technical details

- Max. Load Capacity: 50 kg
- Max. Travel Speed 100 m/min
- Basic trolley and cable support: Steel, hot-dipped galvanized
- Hardware: Galvanized steel
- Standard roller: Ball bearing, galvanized steel

Ordering Example:

Cable Trolley for Flat Cable

Example:

Order a cable trolley with standard-rollers for a flat cable package with a size of 110 x 45 mm (width x thickness).

Selected:

Cable Trolley with
 $d_a = 125$ mm (According to minimum bend diameter of cable)
 $b_2 = 130$ mm
 $s = 55$ mm

Order No.:

Cable Trolley
 Order No.: 025252-250x160

1) For assembly- 2 holes $\phi 12.5$ mm to be drilled into the C-Rail at distance a.

Cable Trolley Order No.	[kg]	Towing Trolley Order No.	[kg]	End Clamp Order No.	[kg]	d_a [mm]	l_w [mm]	k [mm]	b_1 [mm]	b_2 [mm]	s [mm]	l_m [mm]	l_e [mm]	a [mm]
025250-160x100*	1.7	025260-200x100*	2.7	025240-160x100*	1.5	80	160	84	100	70	35	200	80	74
025250-160x160*	1.9	025260-200x160*	3.1	025240-160x160*	1.8				160	130				
025250-200x100	1.9	025260-200x100	2.7	025240-200x100	1.8		200	124	100	70	55	200	100	114
025250-200x160*	2.2	025260-200x160*	3.1	025240-200x160*	2.0				160	130				
025252-200x160*	2.3	025262-200x160*	3.2	025242-200x160*	2.2	125	200	124	160	130	30	200	100	114
025252-250x100	2.3	025262-250x100	3.1	025242-250x100	2.2				250	174				
025252-250x160*	2.6	025262-250x160*	3.5	025242-250x160*	2.5		160	130						
025252-250x200	3.0	025262-250x200	3.8	025242-250x200	2.9		200	170						
025253-250x160*	2.9	025263-250x160*	3.8	025243-250x160*	2.8	160	250	174	175	130	40	250	125	164
025253-250x200	3.2	025263-250x200	4.0	025243-250x200	3.1				215	170				

*Standard range

Cable Trolleys Program 0250

Cable Trolleys for Round Cables

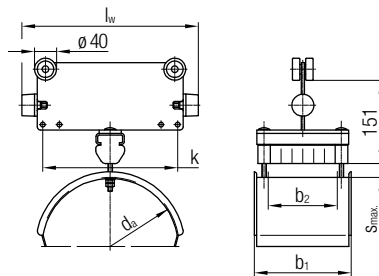

Cable Trolley

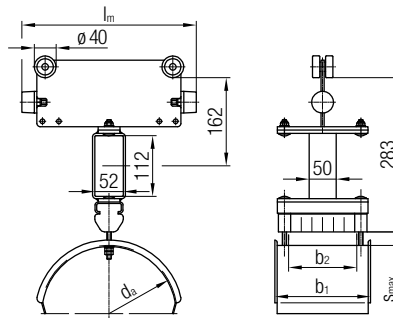

Towing Trolley

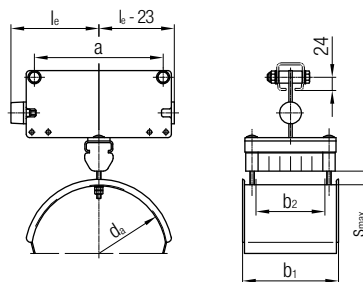

End Clamp¹⁾

Technical details

- Max. Load Capacity: 50 kg
- Max. Travel Speed 100 m/min
- Basic trolley and cable support: Steel, hot-dipped galvanized
- Hardware: Galvanized steel
- Standard roller: Ball bearing, galvanized steel

Ordering Example:

Cable Trolley for Round Cable

Example:

Order a cable trolley with rollers with seal disks for several round cables $\varnothing 25$ mm and a support width of 200 mm.

Selected:

Cable Trolley with
 $d_a = 250$ mm (According to minimum bend diameter of cable)
 $b_2 = 215$ mm
 Roller with Seal Disks 2 RS .../010

Order No.:

Cable Trolley
 Order No.: 025355-320x250/010

1) For assembly- 2 holes $\varnothing 12.5$ mm to be drilled into the C-Rail at distance a.

Cable Trolley Order No.	[kg]	Towing Trolley Order No.	[kg]	End Clamp Order No.	[kg]	d_a [mm]	l_w [mm]	k [mm]	b_1 [mm]	b_2 [mm]	s [mm]	l_m [mm]	l_e [mm]	a [mm]
025354-250x160*	3.7	025364-250x160*	4.5	025344-250x160*	3.6	200	250	174	175	125	20	250	125	164
025354-250x200*	4.0	025364-250x200*	4.8	025344-250x200*	3.9				215	165				
025355-320x160*	4.3	025365-320x160*	5.1	025345-320x160*	4.2	250	320	244	175	125	25	320	160	234
025355-320x250*	5.3	025365-320x250*	6.1	025345-320x250*	5.2				265	215				
025357-400x160	5.1	025367-400x160	5.9	025347-400x160	5.0	320	400	324	175	125	32	400	200	314
025357-400x250	6.2	025367-400x250	7.0	025347-400x250	6.0				265	215				

*Standard range

Pairs of Rollers for Cable Trolleys Program 0250

Description	Roller Type	Sealing Type	Load Capacity [kg]	Special Roller Additional-Order No.
Standard Roller	Ball Bearing, galvanized steel	2 Z	50	-
Roller with Seal Disks		2 RS		.../010

C-Rail and Accessories Program 0255

C-Rail 63 x 63

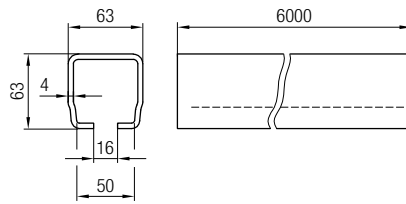
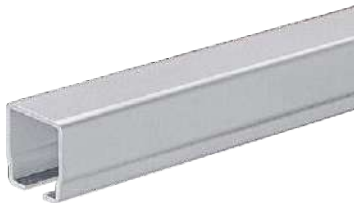

$$I_x = 44.4 \text{ cm}^4; W_x = 13.0 \text{ cm}^3$$

Order No.

025600*

Technical details

- Material: sendzimir galvanized steel
- Weight: 6.55 kg/m
- Standard Length: 6 m

*Standard range

Track Coupler

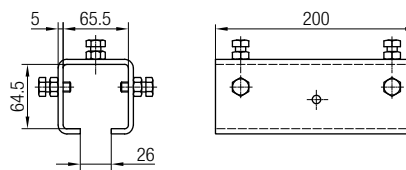

Order No.

025605*

Technical details

- Material: galvanized steel
- Weight: 1.9 kg

*Standard range

End Stops

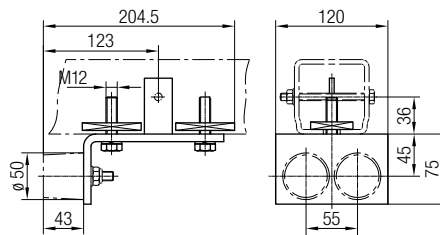

Order No.

025610

without Rubber Buffer

025611*

with Rubber Buffer

Technical details

- Material: galvanized steel
- Weight: 2.5 kg

To avoid system damage we recommend the fitting of a securing bolt as illustrated.

*Standard range

Track Support Brackets

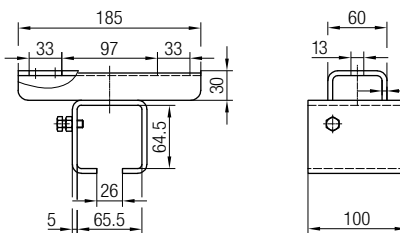

Order No.

025621

Technical details

- Material: galvanized steel
- Perm. Load: 500 kg
- Weight: 1.65 kg

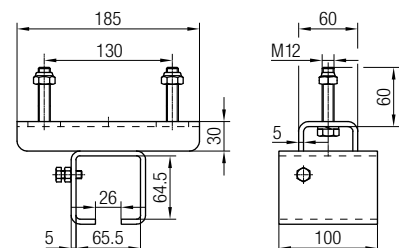

Order No.

025623

Technical details

- Material: galvanized steel
- Perm. Load: 500 kg
- Weight: 1.8 kg

C-Rail and Accessories Program 0255

Track Support Bracket

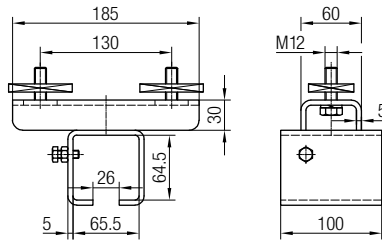

Order No.

025622*

Technical details

- Material: galvanized steel
- Perm. Load: 500 kg
- Weight: 1.8 kg

*Standard range

Support Arm and Girder Clip

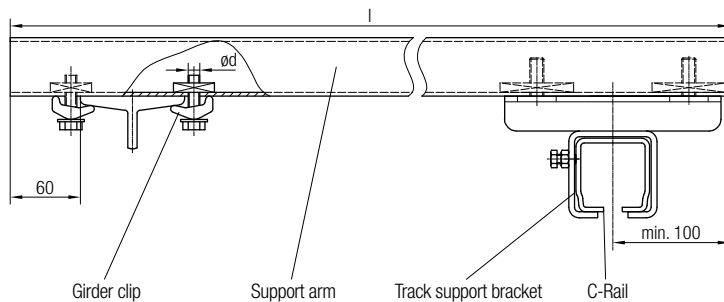

Description	Order No.	l [mm]	Weight [kg]
Support arm	020273-1000*	1000	6.6

Material: sendzimir galvanized steel

Description	Order No.	ø d [mm]	Weight [kg]
Girder clip	020180-12/550*	M12	0.3

Material: galvanized steel

*Standard range

Brackets

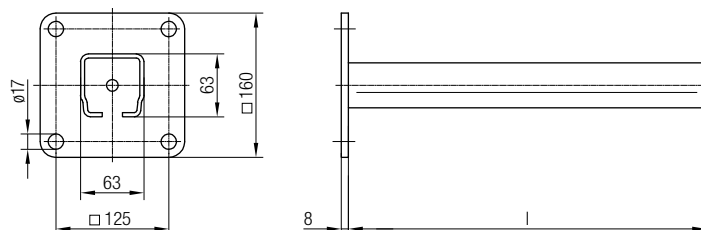

Order No.	l [mm]	Material	Weight [kg]
020192-0500	500	galvanized steel	4.8
020192-0800	800		6.8

Cable Trolleys Program 0255

Cable Trolleys for Flat Cables

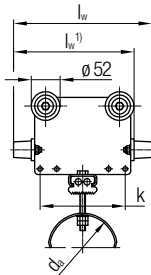

Cable Trolley

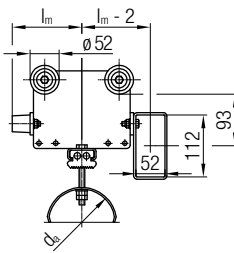
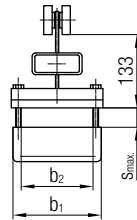

Towing Trolley

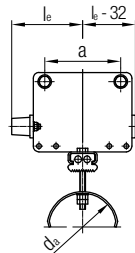
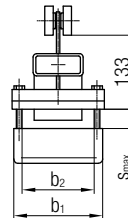

End Clamp¹⁾

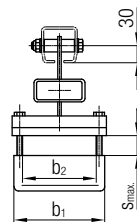

Technical details

- Max. Load Capacity: 80 kg
- Max. Travel Speed 120 m/min
- Basic trolley and cable support: Steel, hot-dipped galvanized
- Hardware: Galvanized steel
- Standard roller: Ball bearing, galvanized steel

Ordering Example:

Cable Trolley for Flat Cable

Example:

Order a cable trolley with standard-rollers for a flat cable package with a size of 140 x 50 mm (width x thickness).

Selected:

Cable Trolley with
 $d_a = 125$ mm (According to minimum bend diameter of cable)
 $b_2 = 168$ mm
 $s = 55$ mm

Order No.:

Cable Trolley
 Order No.: 025772-250x200

1) For assembly- 2 holes $\phi 12.5$ mm to be drilled into the C-Rail at distance a .

Cable Trolley Order No.	[kg]	Towing Trolley Order No.	[kg]	End Clamp Order No.	[kg]	d_a [mm]	l_w [mm]	k [mm]	b_1 [mm]	b_2 [mm]	s [mm]	l_m [mm]	l_e [mm]	a [mm]
025772-220x160*	3.4	025782-320x160*	4.9	025792-320x160*	3.5	125	220 ¹⁾	154	160	128	40	160	160	204
025772-220x200	3.6	025782-320x200	5.1	025792-320x200	3.8				200	168				
025772-250x160*	3.6	025782-320x160*	4.9	025792-320x160*	3.5		250	154	160	128				
025772-250x200*	3.8	025782-320x200*	5.1	025792-320x200*	3.8				200	168				
025773-290x160	4.2	025783-320x160	5.2	025793-320x160	3.8	160	290 ¹⁾	224	175	128	55	160	160	204
025773-290x200	4.3	025783-320x200	5.3	025793-320x200	4.0				215	168				
025773-320x160*	4.3	025783-320x160*	5.2	025793-320x160*	3.8		320	224	175	128				
025773-320x200*	4.5	025783-320x200*	5.3	025793-320x200*	4.0				215	168				
025774-320x160	4.5	025784-320x160	5.3	025794-320x160	4.0	200	320	224	175	128	50	160	160	204
025774-320x200	4.8	025784-320x200	5.6	025794-320x200	4.3				215	168				

*Standard range

Cable Trolleys Program 0255

Cable Trolleys for Round Cables

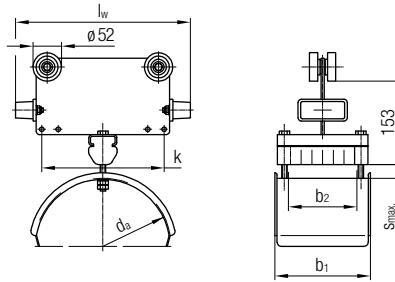

Cable Trolley

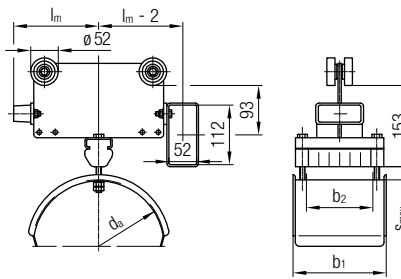

Towing Trolley

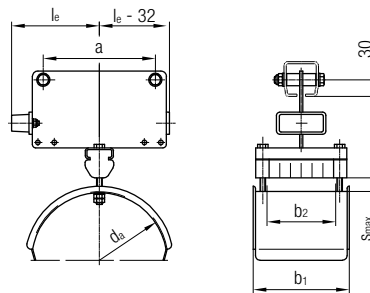

End Clamp¹⁾

Technical details

- Max. Load Capacity: 80 kg
- Max. Travel Speed 120 m/min
- Basic trolley and cable support: Steel, hot-dipped galvanized
- Hardware: Galvanized steel
- Standard roller: Ball bearing, galvanized steel

Ordering Example:

Cable Trolley for Round Cable

Example:

Order a cable trolley with rollers with seal disks for several round cables $\varnothing 25$ mm and a support width of 200 mm.

Selected:

Cable Trolley with
 $d_a = 250$ mm (According to minimum bend diameter of cable)
 $b_2 = 211$ mm
 Roller with Seal Disks 2 RS .../015

Order No.:

Cable Trolley
 Order No.: 025875-320x250/015

1) For assembly- 2 holes $\varnothing 12.5$ mm to be drilled into the C-Rail at distance a.

Cable Trolley Order No.	[kg]	Towing Trolley Order No.	[kg]	End Clamp Order No.	[kg]	d_a [mm]	l_w [mm]	k [mm]	b_1 [mm]	b_2 [mm]	s [mm]	l_m [mm]	l_e [mm]	a [mm]
025875-320x200*	5.3	025885-320x200*	6.1	025895-320x200*	4.7	250	320	224	215	161	25	160	160	204
025875-320x250*	5.8	025885-320x250*	6.6	025895-320x250*	5.3				265	211				
025877-400x200*	6.2	025887-400x200*	7.0	025897-400x200*	5.7	320	400	304	215	161	32	200	200	284
025877-400x250*	6.7	025887-400x250*	7.5	025897-400x250*	6.2				265	211				

*Standard range

Pairs of Rollers for Cable Trolleys Program 0255

Description	Roller Type	Sealing Type	Load Capacity [kg]	Special Roller Additional-Order No.
Standard Roller	Ball Bearing, galvanized steel	2 Z	80	-
Roller with Seal Disks		2 RS		.../015

C-Rail and Accessories Program 0260

C-Rail 80 x 80

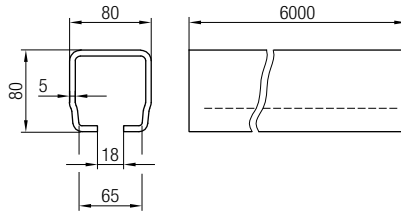

$$I_x = 117.8 \text{ cm}^4; W_x = 27.4 \text{ cm}^3$$

Order No.

148005*

Technical details

- Material: galvanized steel
- Weight: 10.6 kg/m
- Standard Length: 6 m

*Standard range

Track Coupler

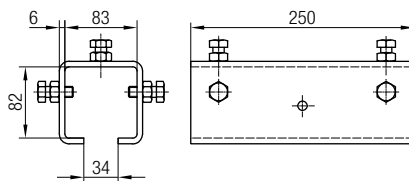

Order No.

026105*

Technical details

- Material: galvanized steel
- Weight: 3.6 kg

*Standard range

End Stop

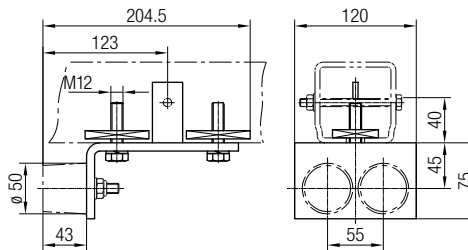

Order No.

026111*

with Rubber Buffer

Technical details

- Material: galvanized steel
- Weight: 2.4 kg

To avoid system damage we recommend the fitting of a securing bolt as illustrated.

*Standard range

Track Support Bracket

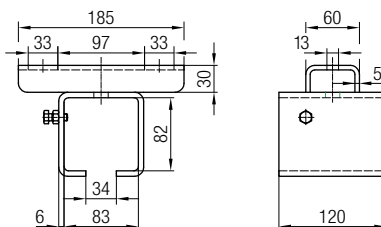

Order No.

026121*

Technical details

- Material: galvanized steel
- Perm. Load: 630 kg
- Weight: 2.4 kg

*Standard range

C-Rail and Accessories Program 0260

Track Support Brackets

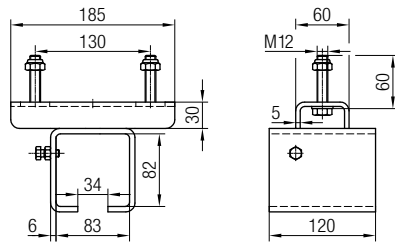

Order No.

026123

Technical details

- Material: galvanized steel
- Perm. Load: 630 kg
- Weight: 2.5 kg

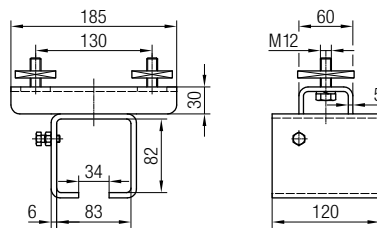

Order No.

026122

Technical details

- Material: galvanized steel
- Perm. Load: 630 kg
- Weight: 2.5 kg

Brackets

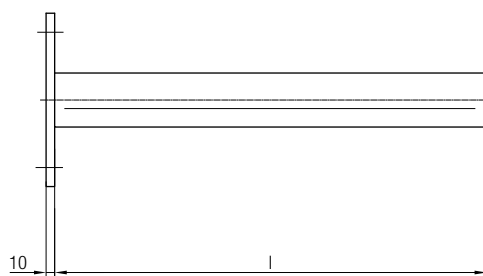
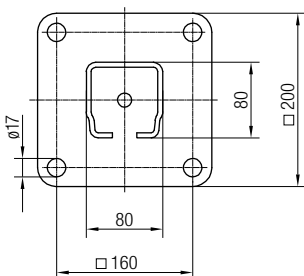

Order No.	l [mm]	Material	Weight [kg]
020193-0500	500	galvanized steel	8.4
020193-0800	800		11.6

Cable Trolleys Program 0260

Cable Trolleys for Flat Cables

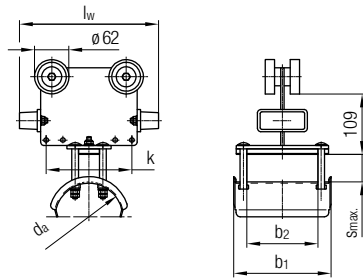

Cable Trolley

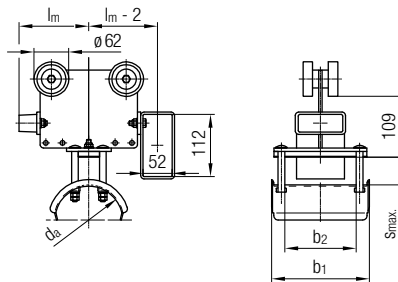

Towing Trolley

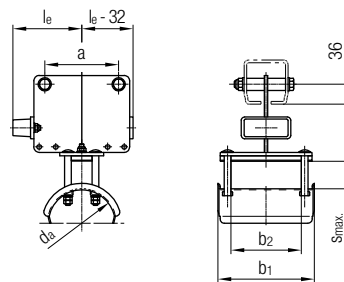

End Clamp¹⁾

Technical details

- Max. Load Capacity: 125 kg
- Max. Travel Speed 120 m/min
- Basic trolley and cable support: Steel, hot-dipped galvanized
- Hardware: Galvanized steel
- Standard roller: Ball bearing, galvanized steel

Ordering Example:

Cable Trolley for Flat Cable

Example:

To order a cable trolley with standard-rollers for a flat cable package with a size of 160 x 60 mm (width x thickness).

Selected:

Cable Trolley with
 $d_a = 160$ mm (According to minimum bend diameter of cable)
 $b_2 = 168$ mm
 $s = 70$ mm

Order No.:

Cable Trolley
 Order No.: 026273-320x200

1) For assembly- 2 holes $\phi 12.5$ mm to be drilled into the C-Rail at distance a.

Cable Trolley Order No.	[kg]	Towing Trolley Order No.	[kg]	End Clamp Order No.	[kg]	d_a [mm]	l_w [mm]	k [mm]	b_1 [mm]	b_2 [mm]	s [mm]	l_m [mm]	l_e [mm]	a [mm]
026272-250x160*	4.6	026282-320x160*	5.9	026292-320x160*	3.6	125	250	154	175	128	55	160	160	204
026272-250x200*	4.9	026282-320x200*	6.2	026292-320x200*	3.9				215	168				
026272-250x250	5.2	026282-320x250	6.6	026292-320x250	4.3				265	218				
026273-320x160*	5.2	026283-320x160*	6.1	026293-320x160*	3.7	160	320	224	175	128	70	160	160	204
026273-320x200	5.6	026283-320x200	6.4	026293-320x200	4.1				215	170				
026273-320x250*	6.0	026283-320x250*	6.8	026293-320x250*	4.5				265	218				

*Standard range

Cable Trolleys Program 0260

Cable Trolleys for Round Cables

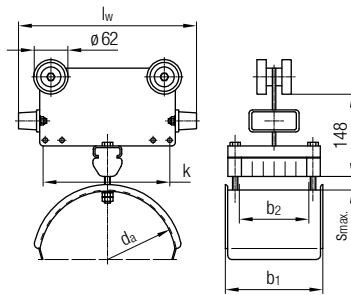

Cable Trolley

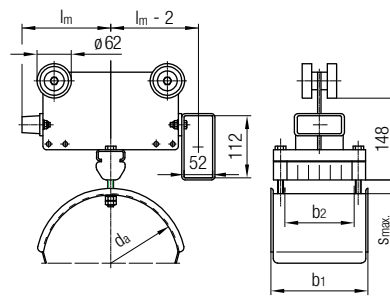

Towing Trolley

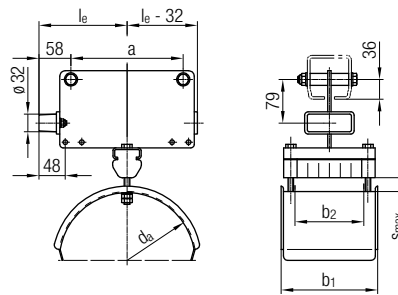

End Clamp¹⁾

Technical details

- Max. Load Capacity: 125 kg
- Max. Travel Speed 120 m/min
- Basic trolley and cable support: Steel, hot-dipped galvanized
- Hardware: Galvanized steel
- Standard roller: Ball bearing, galvanized steel

Ordering Example:

Cable Trolley for Round Cable

Example:

Order a cable trolley with rollers with seal disks for several round cables $\varnothing 32$ mm and a support width of 108 mm.

Selected:

Cable Trolley with
 $d_a = 320$ mm (According to minimum bend diameter of cable)
 $b_2 = 211$ mm
 Roller with Seal Disks 2 RS .../015

Order No.:

Cable Trolley
 Order No.: 026377-400x250/015

1) For assembly- 2 holes $\varnothing 12.5$ mm to be drilled into the C-Rail at distance a.

Cable Trolley Order No.	[kg]	Towing Trolley Order No.	[kg]	End Clamp Order No.	[kg]	d_a [mm]	l_w [mm]	k [mm]	b_1 [mm]	b_2 [mm]	s [mm]	l_m [mm]	l_e [mm]	a [mm]
026375-320x200*	5.9	026385-320x200*	6.7	026395-320x200*	4.8	250	320	224	215	161	25	160	160	204
026375-320x250*	6.4	026385-320x250*	7.3	026395-320x250*	5.4				265	211				
026377-400x200	6.8	026387-400x200	7.7	026397-400x200	5.8	320	400	304	215	161	32	200	200	284
026377-400x250	7.3	026387-400x250	8.2	026397-400x250	6.3				265	211				

*Standard range

Pairs of Rollers for Cable Trolleys Program 0260

Description	Roller Type	Sealing Type	Load Capacity [kg]	Special Roller Additional-Order No.
Standard Roller	Ball Bearing, galvanized steel	2 Z	125	-
Roller with Seal Disks		2 RS		.../015

Cable Trolleys Light Version

Cable Trolleys for Flat Cables

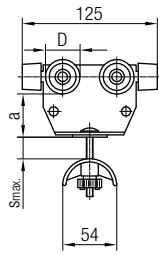

Cable Trolley

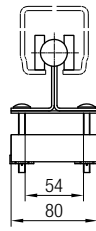

End Clamp

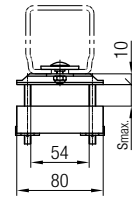
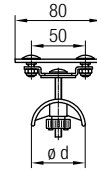

Technical details

- Main Body: sendzimir galvanized steel
- Buffer: rubber
- Support: plastic
- Insulating Plate: plastic
- Split Nut: plastic
- Hardware: galvanized steel

For C-Rail	Program	Cable Trolley Order No.	[kg]	End Clamp Order No.	[kg]	D [mm]	ø d [mm]	a [mm]	s [mm]	Load Capacity [kg]
50 x 50	0250	025270-125x080*	0.45	025290*	0.20	25	50	42	35	20
		025271-125x080*	0.47	025291*	0.23		80	42	20	
63 x 63	0255	025770-125x080*	0.56	025290*	0.20	32	50	38	35	32
		025771-125x080*	0.58	025291*	0.23		80	38	20	
80 x 80	0260	026270-125x080*	0.58	025290*	0.22	32	50	38	35	32
		026271-125x080*	0.60	025291*	0.25		80	38	20	

*Standard range

Cable Trolleys for Round Cables

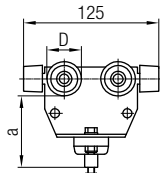

Cable Trolley

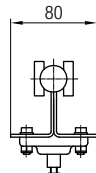

End Clamp

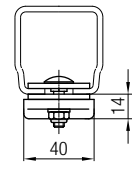
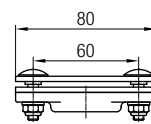

Technical details

- Main Body: sendzimir galvanized steel
- Buffer: rubber
- Ball Joint: plastic
- Connecting Plate: plastic
- Hardware: galvanized steel

For C-Rail	Program	Cable Trolley Order No.	[kg]	End Clamp Order No.	[kg]	D [mm]	ø d [mm]	Load Capacity [kg]
50 x 50	0250	025306*	0.35	025308*	0.25	25	70	20
63 x 63	0255	025806*	0.45	025808*	0.25	32	66	32
80 x 80	0260	026306*	0.48	025808*	0.27			

*Standard range

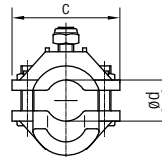
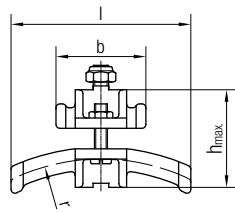

If required, it is possible to fit one or more similar or different sized cable clips to a trolley. When fitting different sized cable clips, the largest cable clip must be fitted on top.

Order No.	ø d [mm]	r [mm]	l [mm]	h [mm]	b [mm]	c [mm]	Cable clip Material	Fasteners	Weight [kg]
020131-16*	10-16	80	70	38	35	42	Plastic	Galvanized Steel	0.04
020131-25*	17-25	125	100	47	50	50			0.06
020131-36*	26-36	180	140	58	70	64			0.12

*Standard range

Cable Trolleys

Light Version

Trolleys with 4 Rollers

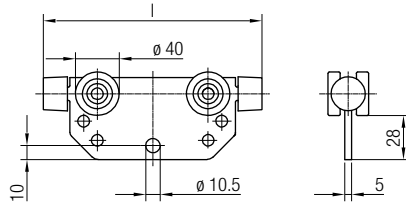

Technical details

- Main body: galvanized steel
- Roller (ball bearing): galvanized steel
- Buffer: rubber

For C-Rail	Program	Order No.	Weight [kg]	l [mm]	Load Capacity [kg]
50 x 50	0250	025440-125	0.42	125	50
		025440-160	0.50	160	

Spring Safety Hook

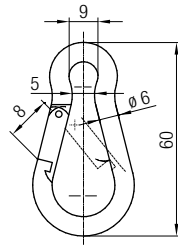

Order No.

020215-60x6

Technical details

- Material galvanized steel

End Stops

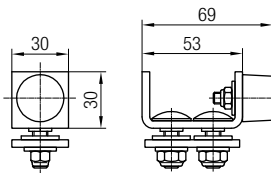

Technical details

- Material: galvanized steel
- Hardware: galvanized steel
- Buffer: rubber

For C-Rail	Program	Order No.	Type	Weight [kg]
50 x 50	0250	025115*	with Buffer	0.20
63 x 63	0255	025115*		0.20
80 x 80	0260	026115*		0.22

*Standard range

Accessories for Festoon Systems Program 0250, 0255 and 0260

Towing Ropes

Type B

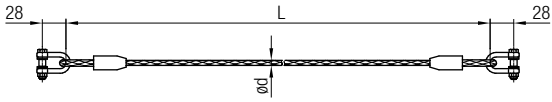

Type C

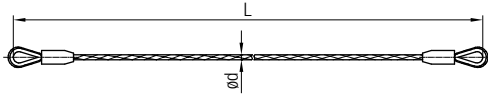

Type C suggested for use with damping devices.
Different types and lengths available upon request.

Order No.	ø d [mm]	Material Rope	Type	for Program
020328-06	6	Galvanized Steel	B	0250, 0255, 0260
020329-08	8	Galvanized Steel with PVC Jacket		
020325-08	8	Galvanized Steel with PVC Jacket	C	

Damping Devices

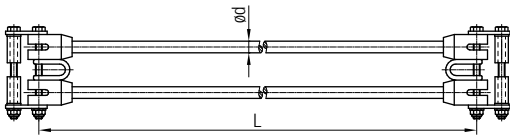

Different types and lengths available upon request.

Order No.	ø d [mm]	Material Rope	for Program
020337-10	10	Rubber core with Nylon jacket	0250, 0255, 0260
020337-14	14		

Accessories for Festoon Systems Program 0250, 0255 and 0260

Round Cable Clamps

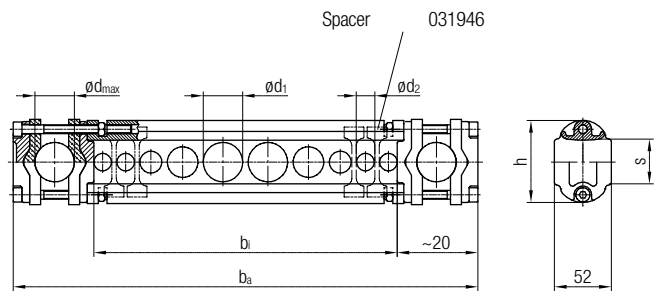

Order No.	$\varnothing d_{max}$ [mm]	b_i [mm]	b_a [mm]	h [mm]	s [mm]	$\Sigma d^{1)}$ [mm]	Support Rail	Material Cable Clip	Fasteners
031941-026x100/400	26	100	236	64	30	34	Aluminum	Rubber	Stainless Steel
031941-026x150/400		150	286						
031941-026x200/400		200	336						
031941-026x250/400		250	386						
031941-036x100/400	36	100	256	74	40	46			
031941-036x150/400		150	306						
031941-036x200/400		200	356						
031941-036x250/400		250	406						

1) A cable separator is required between cables if the sum of the diameters of two adjacent cables is smaller than the value Σd .

Spacers

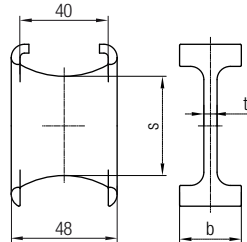

Order No.	s [mm]	t [mm]	b [mm]	Material	Used with Round Cable Clamp
031946-26	25	4	18	Plastic	031941-026x...
031946-36	35	5	19		031941-036x...

Accessories for Festoon Systems Program 0250, 0255 and 0260

Flat Cable Organizer



Power cables are clamped in upper window s_1 , control cables are contained in lower window s_2 with sufficient space ($> 2\text{ mm}$) to allow the cables to move freely.

Flat cable clamps are supplied pre-assembled with upper window s_1 of minimum size and lower window s_2 of maximum size. The cable clamps can be adjusted to fit cable packages by transferring spacers from window s_2 to window s_1 .

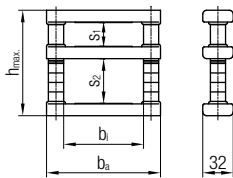
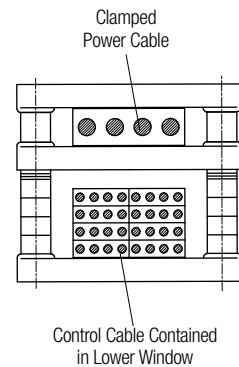

Order No.
020126... and 031953...

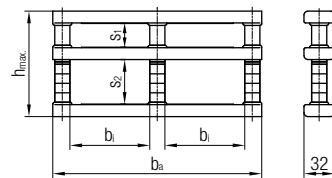

Order No. 031955...

Order No.	b_i [mm]	b_a [mm]	$s_1 + s_2$ [mm]		$s_{1min.}$ [mm]	$h_{max.}$ [mm]	Material		Weight [kg]
							Cable Clamps	Fasteners	
020126-054x018	54	90	18	+2.5	3	50	Galvanized Steel	0.07	
020126-054x028			28			60		0.08	
020126-054x038			38			70		0.09	
031953-084x025/400	84	120	25	+2.5	5	60	Plastic	0.16	
031953-084x035/400			35			70		0.17	
031953-084x045/400			45			80		0.18	
031953-084x055/400			55			90		0.19	
031953-084x065/400			65			100		0.21	
031953-136x025/400			25			60		0.22	
031953-136x035/400			35			70		0.23	
031953-136x045/400	45	80	0.24						
031953-136x055/400	55	90	0.25						
031953-136x065/400	65	100	0.26						
031953-136x075/400	75	110	0.27						
031953-136x085/400	85	120	0.28						
031955-084x035/400	84	220	35	+2.5	5	70	Stainless Steel	0.41	
031955-084x045/400			45			80		0.43	
031955-084x055/400			55			90		0.44	
031955-084x065/400			65			100		0.46	
031955-084x075/400			75			110		0.48	
031955-103x025/400	103	258	25	+2.5	5	60	Stainless Steel	0.42	
031955-103x035/400			35			70		0.43	
031955-103x045/400			45			80		0.46	
031955-103x055/400			55			90		0.47	
031955-103x065/400			65			100		0.49	
031955-103x075/400			75			110		0.51	

Helpful Hints

Determining the Support Distance for C-Rail Program 0250

Technical Data / Calculation Assumptions

The required support distance of the C-rail can be determined using the diagram below.
The following calculation assumptions have been taken into consideration:

1. Simply-supported beam, uniform load symmetrical to middle of the beam
2. The load of one trolley F_{LW} [kg/trolley] is distributed over trolley length l_W as a uniform load p [kg/m]
3. Total length of the uniform load results from the cable trolley storage length l_b [m] of all trolleys side by side
4. $\sigma_{b_{zul}} = 100\text{N/mm}^2$, without consideration of the lower flange stress
5. $\sigma_V \leq 160\text{N/mm}^2$, reference stress from bending stress and lower flange stress
6. $f = l_A/250$ permissible deflection from the load and net weight of the rail
7. As track support bracket load the load of a field symmetrical to the mounting (bracket) is assumed

Example:

Given:

F_{LW} = Cable Trolley Load: 28 kg (X axis value on the left-hand graph below)
 l_W = Cable Trolley Length: 200 mm (blue line on the left graph)
 Z = Overall number of Cable Trolleys: 8
 l_b = Cable Trolley Storage Length: 1.6 m (X axis on the right-hand graph below)
 (m) = $Z \times l_W / 1000$

Load Diagram for C-Rail 50 x 50 x 3.5 (025100)

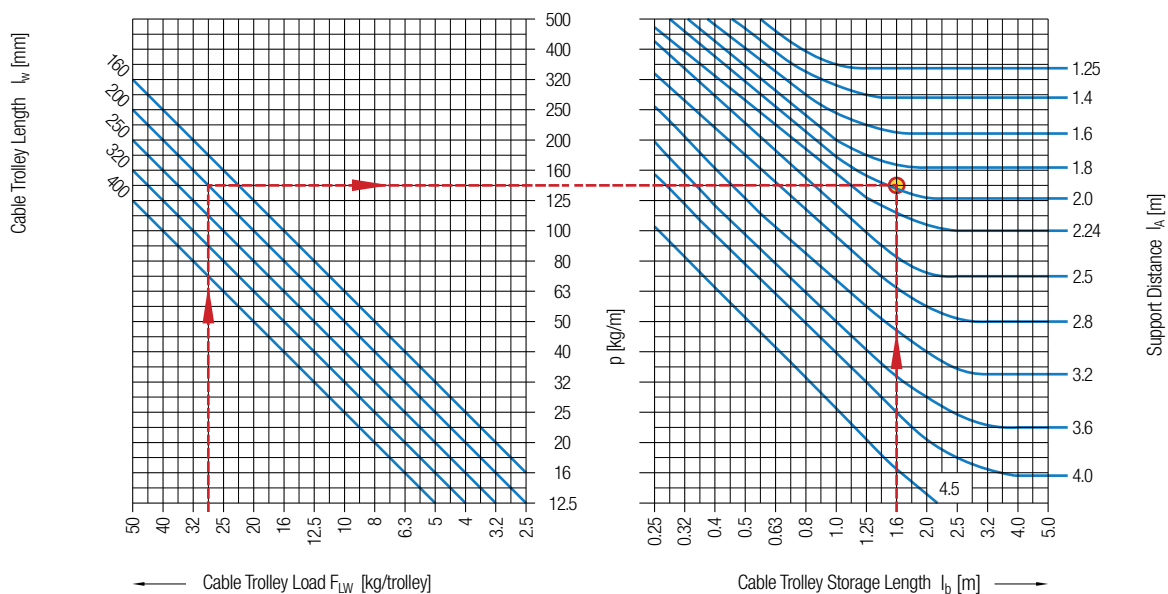

Solution for C-Rail 50 x 50 x 3.5

From diagram: Required Support Distance $l_A = 1.9$ m

Helpful Hints

Load diagram for C-Rail 63 x 63 x 4 (025600)

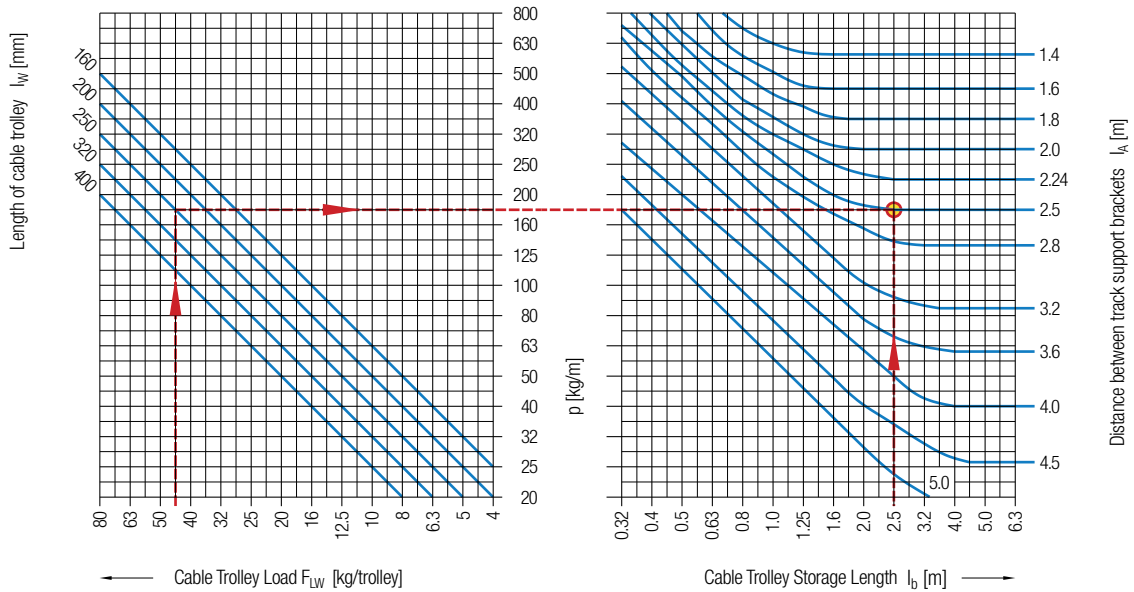

Example:

Given:

F_{LW} = Cable Trolley Load: 45 kg
 l_w = Cable Trolley Length: 250 mm
 Z = Overall number of Cable Trolleys: 10
 l_b = Cable Trolley Storage Length: 2.5 m
 $(m) = Z \times l_w / 1000$

Solution for C-Rail 63 x 63 x 4

From Diagram: Required Support Distance $l_A = 2.5$ m

Load diagram for C-Rail 80 x 80 x 5 (148005)

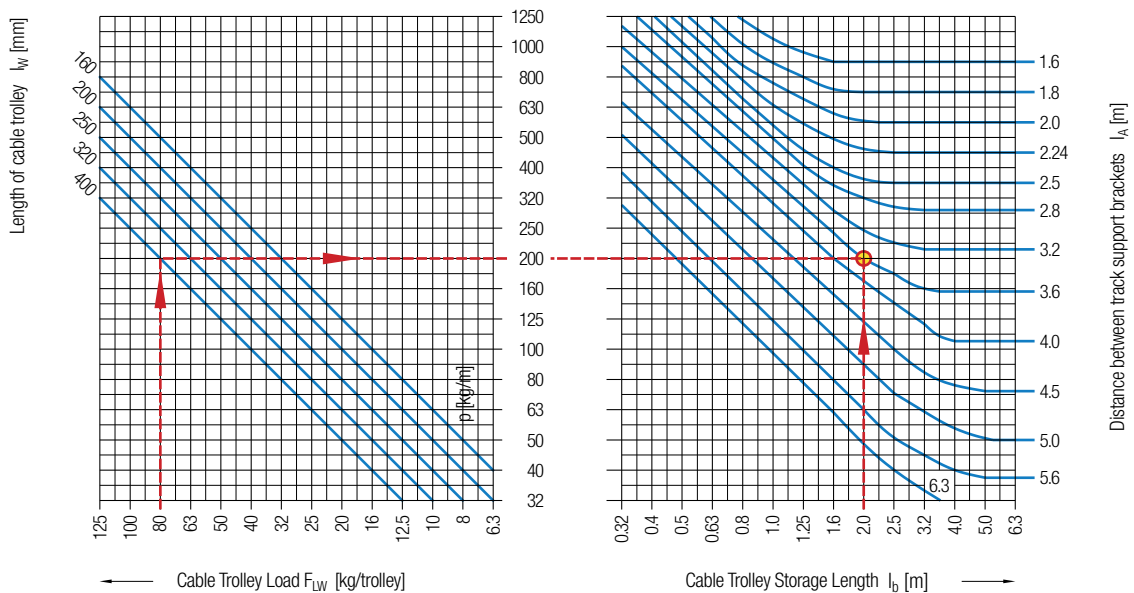

Example:

Given:

F_{LW} = Cable Trolley Load: 80 kg
 l_w = Cable Trolley Length: 400 mm
 Z = Overall number of Cable Trolleys: 5
 l_b = Cable Trolley Storage Length: 2 m
 $(m) = Z \times l_w / 1000$

Solution for C-Rail 80 x 80 x 5

From Diagram: Required Support Distance $l_A = 3.6$ m

Helpful Hints

Technical Data

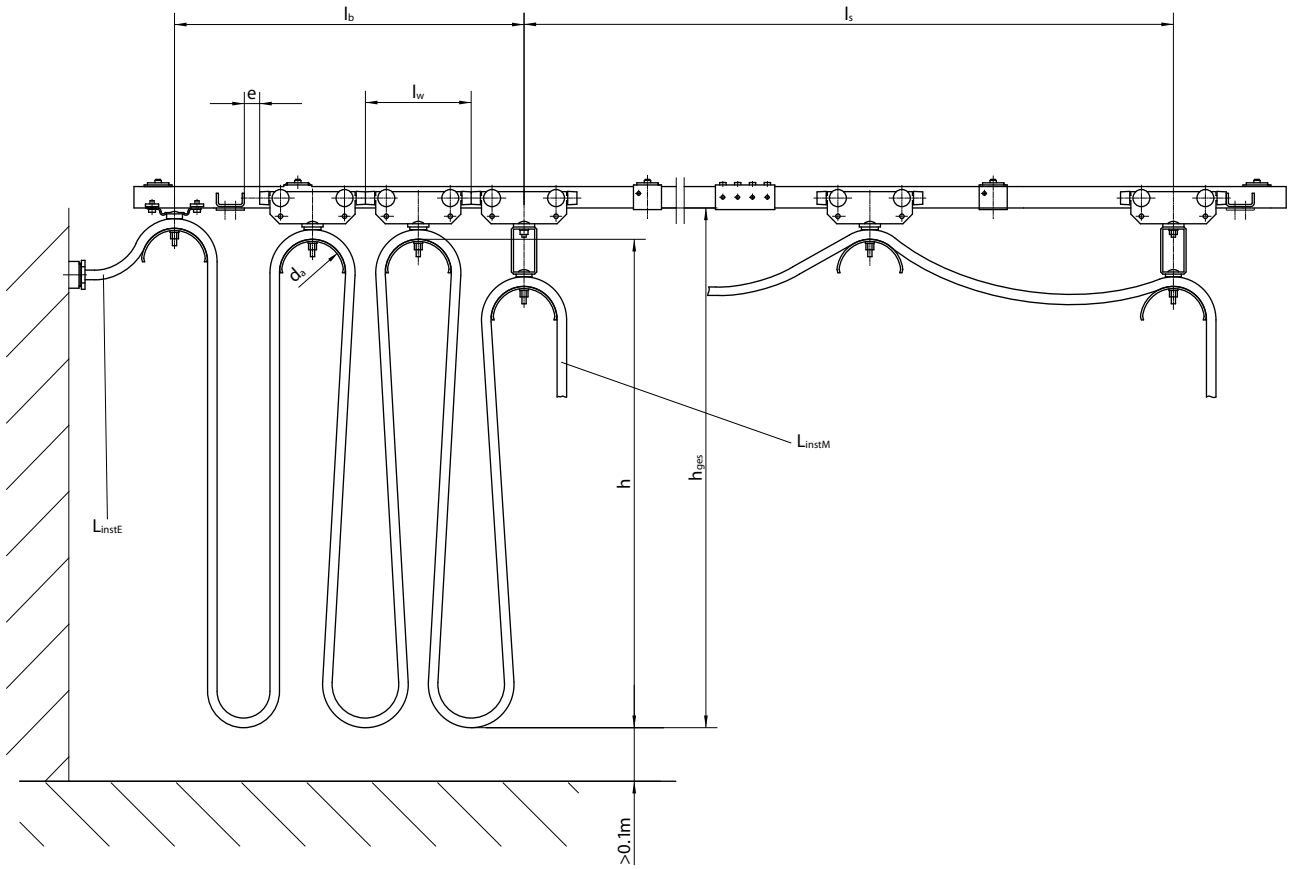

Formulas to Determine the Number of Loops, Cable Length and Loop Depth

Number of loops:

$$n = \frac{f(l_s + e)}{2 \cdot h + 1.25 d_a - f \cdot l_w}$$

Storage length:

$$l_b \approx n \cdot l_w + e \quad [\text{m}]$$

System cable length:

$$L_{\text{Syst}} = f(l_s + l_b) \quad [\text{m}]$$

Total cable length:

$$L_{\text{Best}} = L_{\text{Syst}} + L_{\text{instE}} + L_{\text{instM}} \quad [\text{m}]$$

Loop length:

$$L_{\text{Schl}} = \frac{L_{\text{Syst}}}{n} \quad [\text{m}]$$

Loop depth:

$$h = \frac{L_{\text{Schl}}}{2} - 0.63 \cdot d_a \quad [\text{m}]$$

- d_a [m] = cable support diameter
- e [m] = free space in storage area (recommendation ≥ 0.1 m)
- f = recommended cable factor (see table page 24)
- h [m] = loop depth (measured from top edge of cable support)
- h_{ges} [m] = loop depth (measured from lower edge of track profile)
- l_b [m] = storage length incl. free space
- l_s [m] = travel distance
- l_w [m] = cable trolley length
- L_{Best} [m] = total cable length
- L_{instE} [m] = installation length, end clamp side
- L_{instM} [m] = installation length, towing side
- L_{Schl} [m] = cable length per loop
- L_{Syst} [m] = required cable length (measured from mid of end clamp to mid of towing trolley or towing clamp)
- n = number of loops

Helpful Hints

Definition of the cable arrangement and cable trolley selection

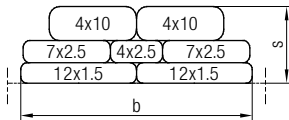

Example for flat cable trolleys

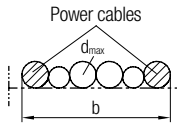

Example for round cable trolleys

1. Formula for calculating the approximate load per trolley F_{LW}

$$F_{LW} \approx 2 \cdot h \cdot G_L \quad [\text{kg}]$$

G_L [kg/m] = weight of the cable package

2. Selection of the cable trolley type
3. Required cable support diameter based upon minimum bending radius of the cables
4. Select cable support width b_2 to accommodate the cable package width
5. Determine length of trolley l_w

For round cables:

$$l_w \geq d_a + 2 \cdot d_{\max} + 10 \quad [\text{mm}]$$

For flat cables:

$$l_w \geq d_a + 2 \cdot s + 10 \quad [\text{mm}]$$

Cable Factors

Travel Speed v [m/min]	Cable Factor f at h [m]				
	< 0.8	0.8 - 1.2	1.3 - 2	2.1 - 3.2	3.3 - 5
< 32	1.10	1.10	1.10	1.10	1.10
32 - 040	1.15	1.10	1.10	1.10	1.10
41 - 050	1.20	1.15	1.10	1.10	1.10
51 - 063	1.25	1.20	1.15	1.10	1.10
64 - 080	-	1.25	1.20	1.15	1.10
81 - 100	-	-	1.25	1.20	1.15
101 - 120	-	-	-	1.25	1.20

Depending on the operating conditions the cables must be installed with an additional cable length. The additional length is calculated by taking into account the cable factor f . We recommend to select the cable factor according to above table. For values outside the gray area, please contact us directly. Special precautions might be required in those cases under extreme operating conditions, such as the installation of shock cords.

Permissible Loads of the Rollers

Travel Speed v [m/min]	Average Running Time per Day [h]				
	4 - 8	8 - 16	> 16	-	-
< 25	4 - 8	8 - 16	> 16	-	-
25 - 50	2 - 4	4 - 8	8 - 16	> 16	-
51 - 80	< 2	2 - 4	4 - 8	8 - 16	> 16
101 - 120	-	-	2 - 4	4 - 8	8 - 16

Program	Steel Roller \emptyset [mm]	Permissible Load per Trolley [kg]				
		80	63	50	40	32
0250	40	80	63	50	40	32
0255	52	125	100	80	63	50
0260	62	200	160	125	100	80

Program	PU Roller \emptyset [mm]	Permissible Load per Trolley [kg]				
		63	50	40	32	25
0250	40	63	50	40	32	25
0255	52	100	80	63	50	40
0260	62	160	125	100	80	63

The lifetime of the rollers depends on the load (Hertzian stress) and the frequency of operation. The proper selection, based on travel speed, average running time per day (based on one year) and permissible load of the trolleys with various roller types, can be made by using the above table.

Wear Parts

Replacement Rollers for Program 0250

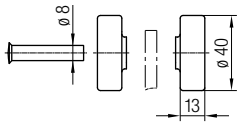

Description	Order No.
Standard Roller	025460-21
Roller with Seal Disks	025462-21

Replacement Rollers for Program 0255

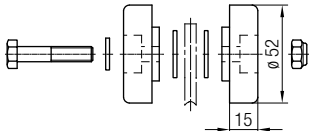

Description	Order No.
Standard Roller	025980-21
Roller with Seal Disks	025985-21

Ersatzrollen für Programm 0260

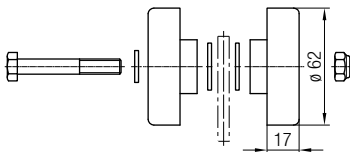

Description	Order No.
Standard Roller	026480-21
Roller with Seal Disks	026460-21

Buffer for Program 0250

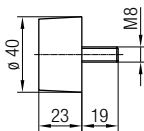

Description	Order No.
Buffer	02-P014-0024

Buffer for Program 0255 und 260

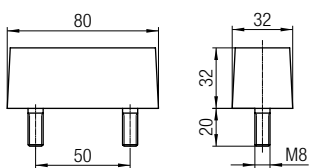

Description	Order No.
Buffer	017132-032x80/514

Shock Cords for Program 0325 and 0330

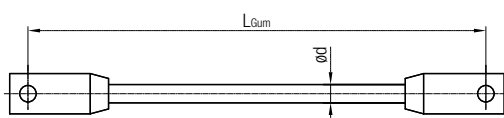

Order No.	ø d [mm]	Weight [kg/m]
020336-10	10	0.09
020336-14	14	0.17

Note
In case of order please state the lengths L_{Gum} of the respective shock cords..

Your Applications – our Solutions

Cable Trolleys from Conductix-Wampfler represent only one of the many solutions made possible by the broad spectrum of Conductix-Wampfler components for the transport of energy, data and fluid media. The solutions we deliver for your applications are based on your specific requirements. In many cases, a combination of several different Conductix-Wampfler systems can prove advantageous. You can count on all of Conductix-Wampfler's Business Units for hands-on engineering support - coupled with the perfect solution to meet your energy management and control needs.



Cable reels

Motorized reels and spring reels by Conductix-Wampfler hold their own wherever energy, data and media have to cover the most diverse distances within a short amount of time - in all directions, fast and safe.



Festoon systems

It's hard to imagine Conductix-Wampfler cable trolleys not being used in virtually every industrial application. They're reliable and robust and available in an enormous variety of dimensions and designs.



Conductor rails

Whether they're enclosed conductor rails or expandable single-pole systems, the proven conductor rails by Conductix-Wampfler reliably move people and material.



Non-insulated conductor rails

Extremely robust, non-insulated conductor rails with copper heads or stainless steel surfaces provide the ideal basis for rough applications, for example in steel mills or shipyards.



Energy guiding chains

The "Jack of all trades" when it comes to transferring energy, data, air and fluid hoses. With their wide range, these energy guiding chains are the ideal solution for many industrial applications.



Slip ring assemblies

Whenever things are really "moving in circles", the proven slip ring assemblies by Conductix-Wampfler ensure the flawless transfer of energy and data. Here, everything revolves around flexibility and reliability!



Inductive Power Transfer IPT®

The no-contact system for transferring energy and data. For all tasks that depend on high speeds and absolute resistance to wear.



Reels, retractors and balancers

Whether for hoses or cables, as classical reels or high-precision positioning aids for tools, our range of reels and spring balancers take the load off your shoulders.



Jib boom

Complete with tool transporters, reels, or an entire media supply system – here, safety and flexibility are key to the completion of difficult tasks.

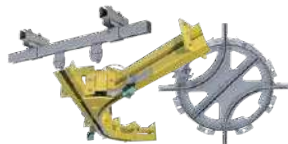

Conveyor systems

Whether manual, semiautomatic or with Power & Free – flexibility is achieved with full customization concerning layout and location.

www.conductix.com

Conductix-Wampfler GmbH

Rheinstrasse 27+33
79576 Weil am Rhein
Germany

Hotline

Phone +49 (0) 7621 662-222

Phone +49 (0) 7621 662-0

Fax +49 (0) 7621 662-144

info.de@conductix.com

www.conductix.com

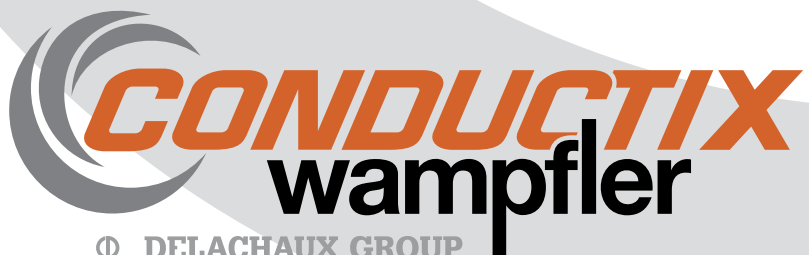

DELACHAUX GROUP