

Besta Power Compressed Air and Electric Supply System Program C40



CONDUCTIX
wampfler
Ⓞ DELACHAUX GROUP

Table of Contents

Overview	4
Product Description	4
System Overview	4
<hr/>	
Rail Components	5
General Information	5
Load Diagram	5
Rail Couplers	6
Rail Support Brackets	7
End Stops	7
Suspensions	8
<hr/>	
Energy Supply	10
General Information	10
<hr/>	
Energy Supply via Energy Guiding Chains	11
Energy Guiding Chains	11
Chain Kit with Supply Lines	11
Guiding Channels	12
Clamping Units	12
Guiding Plate for Power Feed	12
Aluminum Tool Trolley	13
Suspension Trolley	13
<hr/>	
Energy Supply via Festoon System	14
Festoon System	14
Components and Part Numbers	14
Layout Tips	15
Equipment Carrier	16
<hr/>	
Tool Transporter	17
General Information	17
<hr/>	
Accessories	18
Braking Skids	18
Reels, Retractors, and Balancers	18

Overview

Product Description

The BestaPower C40 energy supply system provides mobile consumers with a continuous supply of compressed air, electrical energy, and data through an energy guiding chain or festoon system. The modular assembly and flexible attachment options allow for simple and quick installation.

The main features of BestaPower C40:

- Reliable guiding provided by robust trolleys
- Simple installation using variable brackets
- Compact installation space due to small cross section

System Overview



BestaPower C40 with Energy Guiding Chain



BestaPower C40 with Festoon System

Rail Components

General Information

The classic Conductix-Wampfler C-rail series is electrogalvanized and available in lengths up to six meters. They can be combined into rail lines of any length. Energy can be supplied either through a festoon system or by attaching a cable chain.

C-rail 40

Part No.: 145005

Material: Steel, electrogalvanized
(uncoated rails on request)

Weight: 2,55 kg/m

Length: max. 6 m per rail

Dimensions:
a – 40 mm
b – 40 mm
c – 14 mm
s – 2.5 mm

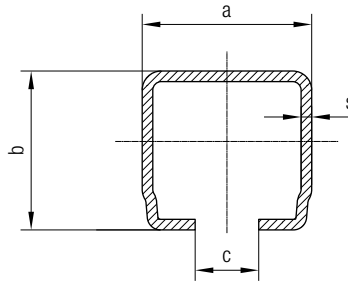

Load Diagram

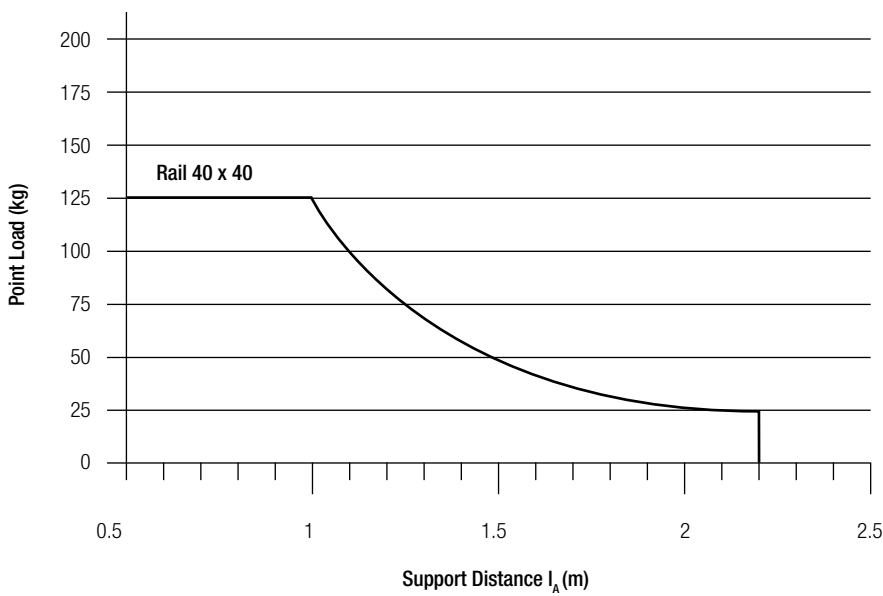

Max. point load: 125 kg

Max. suspension distance: 2.2 m

Rail Components

Rail Coupler

Rail Coupler – Basic Design

Part No.: 145605
Material: Steel, electrogalvanized

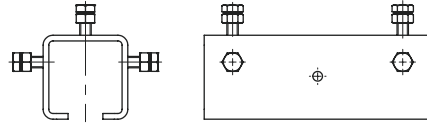

Rail Coupler with Crosshead

Part No.: 145611
Material: Steel, electrogalvanized

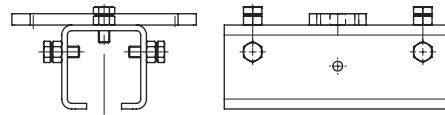
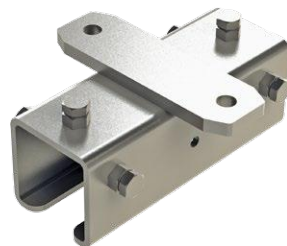

Rail Coupler with Screw

Part No.: 145625-12
Material: Steel, electrogalvanized

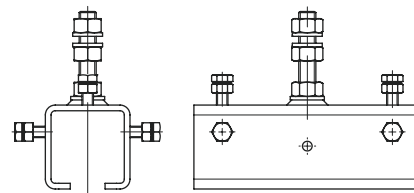

Rail Coupler with Support Arm

Part No.: 145641
Material: Steel, electrogalvanized
Max. clamping distance:
x: 6-20 mm
y: 42-130 mm

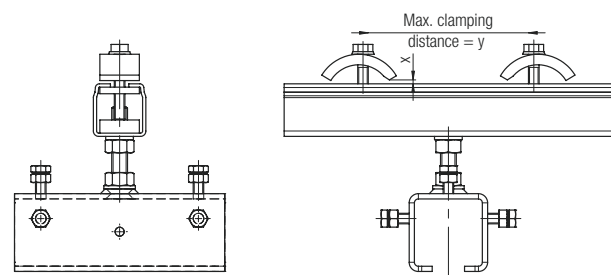

Rail Components

Rail Support Bracket

Rail Support Bracket with Crosshead

Part No.: 145511
Material: Steel, electrogalvanized

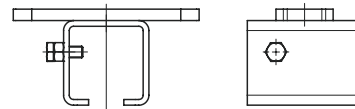

Rail Support Bracket with Screw

Part No.: 145525-12
Material: Steel, electrogalvanized

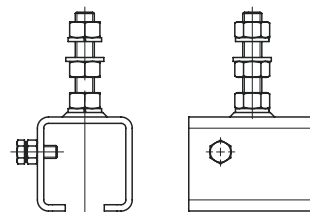

Rail Support Bracket with Support Arm

Part No.: 145541
Material: Steel, electrogalvanized
Max. clamping distance:
 x: 6-20 mm
 y: 42-130 mm

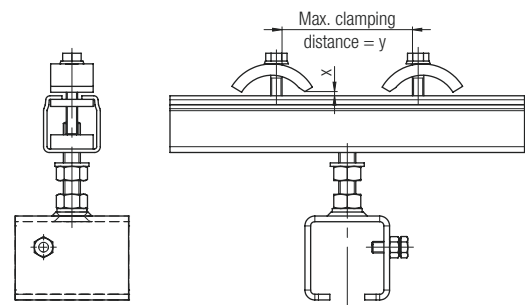

End Stops

Part No.: 145500

Note:
 End Stops must be secured by a safety screw crosswise to the rail. Safety screw is included in the scope of delivery.

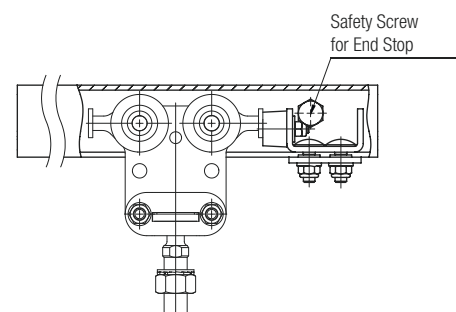
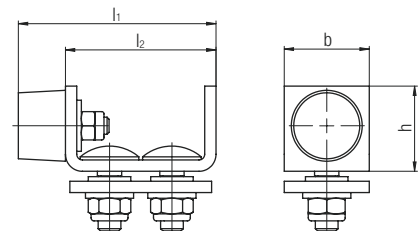

Rail Components

Suspensions

In addition to the various mounting options with Rail Support Brackets directly to the ceiling, suspensions often need to be used, e.g on saw-tooth roofs, or under structural steel work.

Single-point Suspensions

Determining the length of threaded rods (mm):

Diagram 1 and 2:
(for vertical suspension only)

$$L_1 = L_0 - 320$$

Diagram 2 and 3:
(for inclined suspension only)

$$L_2 = \frac{L_0}{\cos \alpha} - 450$$

Diagram 4: L_3 and L_4 have to be determined graphically and calculative, depending on the corresponding incline of the ceiling.

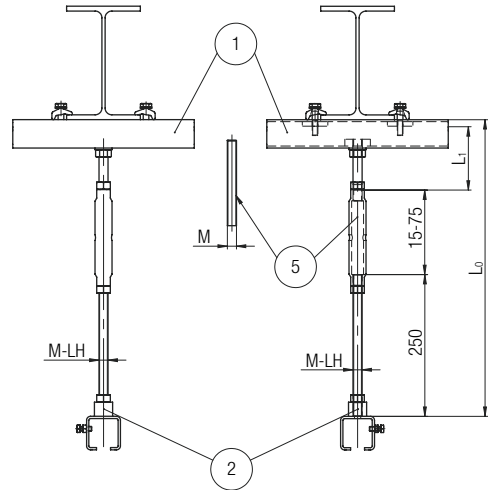

Diagram 1

M-LH = left-handed thread

V-shaped Suspensions

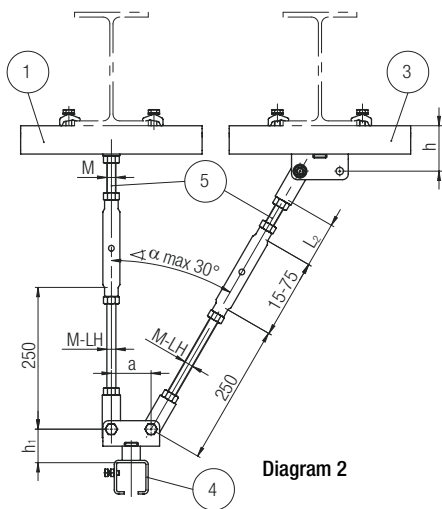

Diagram 2

M-LH = left-handed thread

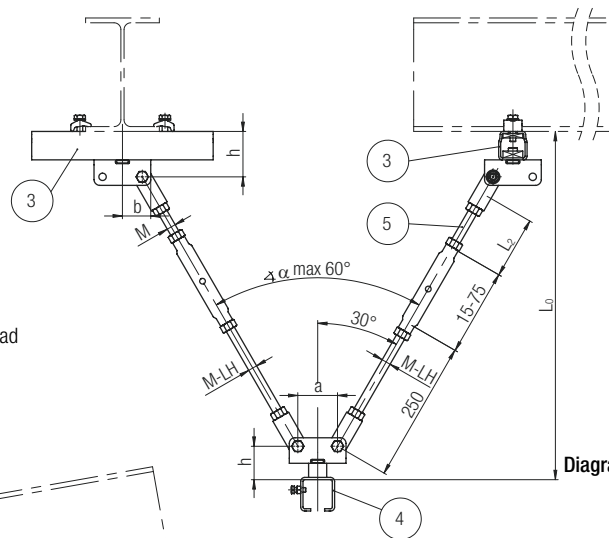

Diagram 3

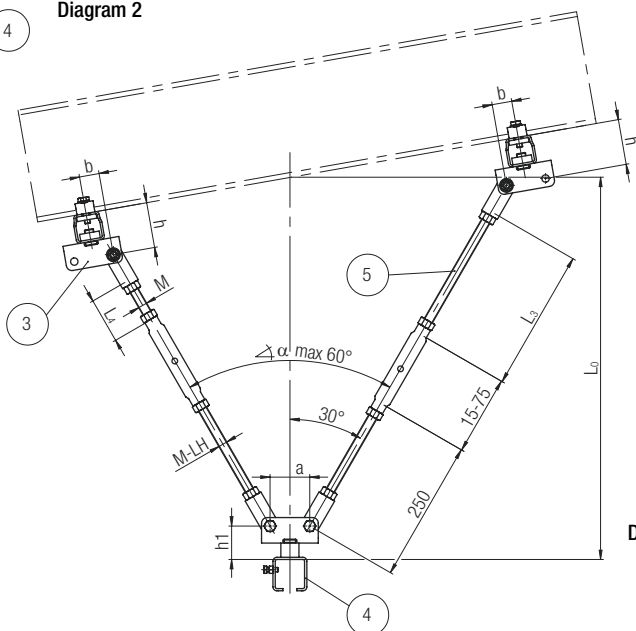

Diagram 4

Rail Components

Suspensions

The bottom parts (Positions 2 or 4) can be rotated to adjust the direction of the rails.

Example Order: Required suspension according to Diagram 2, $L_0=1.5$ m for C-Rail 145005, angle $\alpha = 20^\circ$, Rail Support Bracket version.

Part No.:

- Pos. ① Suspension, upper part – 145211
- Pos. ② Suspension, bottom part – 145221-A
- Pos. ③ Suspension, upper part – 145212
- Pos. ④ Suspension, bottom part – 145222-A
- Pos. ⑤ Threaded rod DIN 975-M12 – 145210-3

Technical Data 40 x 40			
	Description	Position No.	Part No.
Single-point suspension (vertical)	Upper part	①	145211
	Bottom part*	②	145221-A/B
	Threaded rod 3 m	⑤	145210-3
V-shaped suspension (inclined)	Upper part	③	145212
	Bottom part*	④	145222-A/B
	Threaded rod 3 m	⑤	145210-3
Dimensions (mm)	h		90
	h_1		60
	M		M12
	a		60
	b		30

Standard delivery length of threaded rods is 3 m. Cut to desired length before installation.

* Bottom parts ② and ④ are available in the following versions: a) Rail Support Bracket = A, b) Rail Coupler = B

Note: It is vital to state Version A or B when ordering! These bottom parts are delivered with turnbuckles.

Rail Suspension on Concrete Ceilings

When mounted directly on the ceiling, the possibility to adjust the level of the rail track is limited (stiffener plates necessary). Use of Rail Couplers is restricted.

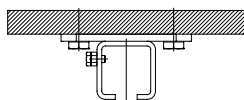

Using Brackets allows for versatile mounting and alignment options.

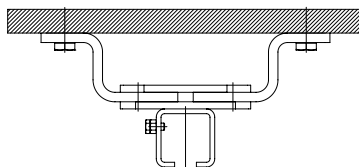

Part No. 145241

(Rail Support Brackets are not included in the scope of delivery)

Note:

When mounting the Rail Suspensions directly below the ceiling, Suspensions have to be shimmed to allow for clamping of the Rail Suspension on the back of the rail. We therefore recommend using our Bracket.

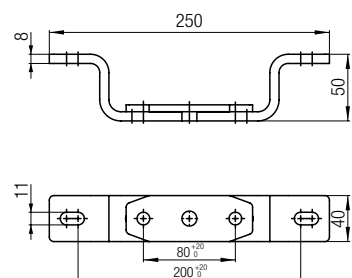
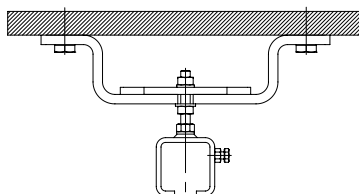

We recommend verification of the load capacity of the ceilings or structural steel work by a structural engineer.









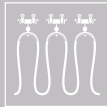

Energy Supply

General Information

There are two different energy supply systems available for the C40 system. These free workplaces from cables and hoses and guide energy to mobile consumers without restriction. Both systems are suitable for the supply of electric and pneumatic energy as well as data transmission.

With the festoon system, the cables and/or hoses are attached to special cable trolleys, which are in turn guided along the rails. This permits the cables/hoses to be guided safely along rails overhead. With the energy guiding chain, the cables and hoses are arranged compactly and safely within a chain. The "reeling out and in" of the chain allows energy to be guided wherever it is needed.

The two systems differ in various characteristics:

	Festoon System	Energy Guiding Chain
		
Advantages / Features		
Pneumatic Energy Supply		
Electrical Energy Supply		
No Restoring Forces		
No Cable Loops		
Full use of the Workspace		
Simple Service and Conversion		
Pressure Loss Factor *	3	1
Installation Time Factor *	3	2

* 1 = very low 2 = average 3 = considerable

Energy Supply

Energy Guiding Chain

The energy guiding chain permits continuous energy supply throughout the workspace. In addition to compressed air hoses, electric and data lines can be safely guided to the consumer. The use of energy guiding chains frees the area around the worker's head from distracting cable slack.

The energy guiding chain, fed at the centre of the cycle, allows for more efficient use of compressed air than with normal festoon or spiral hose systems, as shorter hoses can be used.

The energy guiding chain consists of the following components:

1. Chain Kit with Supply Lines
2. Guiding Channel
3. Clamping Unit
4. Guiding Plate for Power Feed
5. Aluminum Tool Trolley

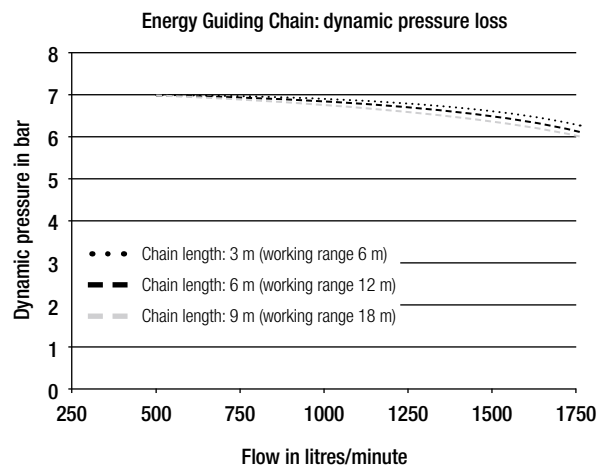
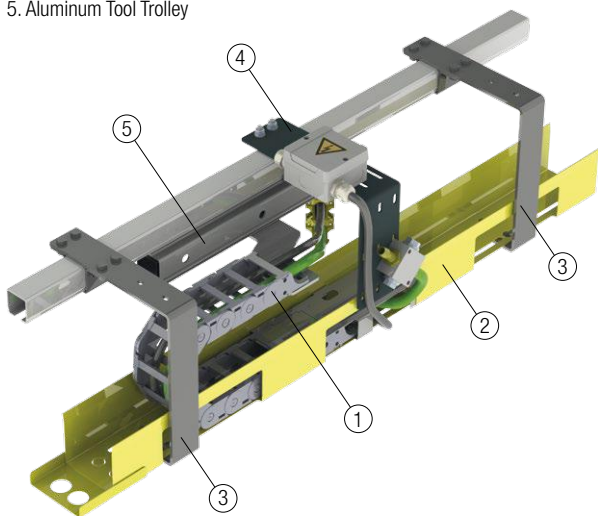

The graph above shows the pressure loss of an energy guiding chain using a 1/2" compressed air hose at an operating pressure of 7 bar.

The pressure loss from the traverse trolley to the consumer or the downstream systems must be added to this in each case.

Energy Guiding Chain – Chain Kit with Supply Lines

In general, a chain kit includes the energy guiding chain with supply lines and the necessary elements for its attachment. Depending on the supply line, the energy guiding chain allows a later elongation. Standard chain kits can be custom-configured with respect to length and desired supply lines.

Part No.: 047735#

Length: Chain is adjusted to fit the cycle. Maximum cycle length: 18 m

Possible supply lines: Compressed air hose with 1/2" inner diameter
Electric cable: 3 x 2.5 mm² or 5 x 2.5 mm²
Data lines and other supply line options upon request

Technical features of chains

Outside measurements, chain: 79 x 35 mm

Inside measurements, chain: 62 x 26 mm

Minimum bending radius: 70 mm

Material: PA

Possible components:

- Chain Actuator
- Traversing plate
- 1/2" hose and/or electric cable
- Hose/cable connection length is configurable and can be cut to fit during installation
- For electric cable: terminal boxes with mounting material
- Accessories for attaching the energy guiding chain



Energy Supply

Energy Guiding Chain – Guiding Channel

The guiding channels carry and guide the chain kit. The number of guiding channels needed is based on the length of the assembly line. The channels are connected endwise using a connection plate.

Part No.:

3-meter length: 047750-03,0

2-meter length: 047750-02,0

1-meter length: 047750-01,0

Material: powder coated steel

Color: RAL 1012, lemon yellow

Other colors available on request.

For fast-moving chains, a guide plate can optionally be attached to the bracket as a rise limiter (not shown).

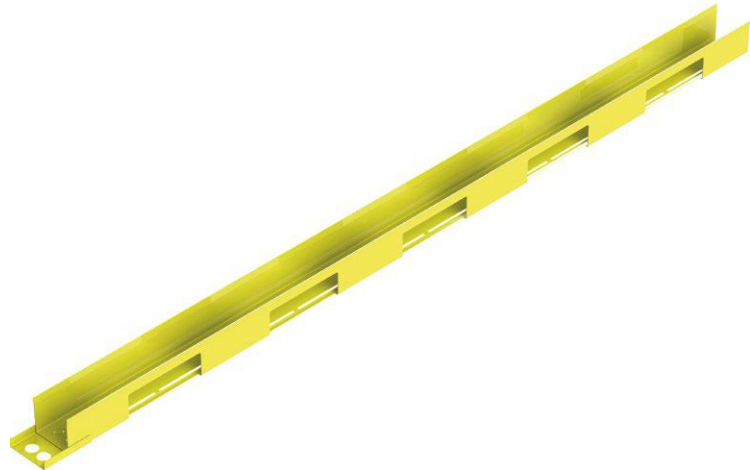

Energy Guiding Chain – Clamping Units

Clamping units are used to fix the guiding channel onto the c-rail.

The track support brackets contain already all accessories needed to fix the guiding channel. They can also be connected to an existing system. The distance between two clamping units should not be greater than 1.5 m to make sure that the system runs smoothly.

Part No.: 047760-40-0235-7016

Material: Steel, epoxy-coated

Color: RAL 7016, anthracite grey

Delivery includes mounting material



Energy Guiding Chain – Guiding Plate for Power Feed

In addition to the guiding channel, a feeding bracket is also available. This is mounted on the rail next to the feed point of the energy guiding chain. Hoses and cables can be attached to the feeding bracket to guide them to the feeding point.

Part No.: 047765-40-0235-7016

Material: Steel, epoxy-coated

Color: RAL 7016, anthracite grey

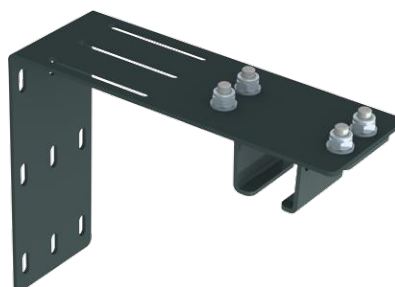

Energy Supply

Energy Guiding Chain – Aluminum Tool Trolley

The tool trolleys are directly connected via the chain actuator of the chain kit to the energy guiding chain. This direct connection ensures a permanent use of energy within the whole system.

The trolley has a standard C-rail slot on the bottom side to which individual accessories such as maintenance units, balancers and more can be attached.

The trolley has a standard length of 400 mm and comes with smooth running Lauramit rollers. Other lengths and steel rollers are available on request.

Part No.: 047770-40-0400
Material: Aluminum
Main roller: Lauramit
Counterpressure roller: Lauramit
Load capacity: 100 kg



Energy Guiding Chain – Suspension Trolleys

Alternatively to the tool trolleys are suspension trolleys connectable to the energy guiding chain.

These are preferably used as parts of a tool transporter (see page xx) or in case of special applications where higher load capacities are needed. Please contact us in case of such requests.

Suspension Trolley – Standard

Part No.: 145020-12B
Material: Galvanized steel
Main roller: Steel
Load capacity: 100 kg

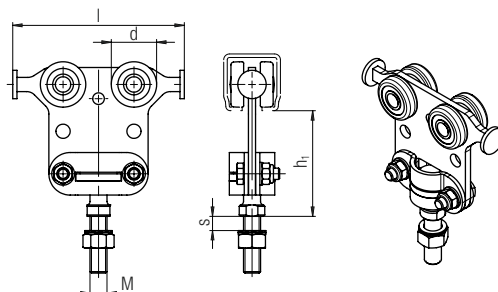

Energy Supply

Festoon System

For short to medium cycle lengths and low compressed air usage, a festoon system is another possible alternative.

The following components are part of the festoon system:

1. End clamp
2. Cable trolley
3. Cable/hose
4. Cable holder
5. End stop
6. Equipment carrier

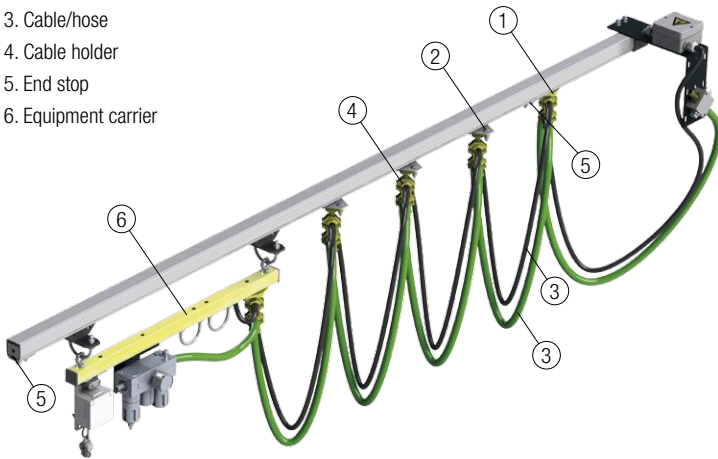

Festoon System: dynamic pressure loss

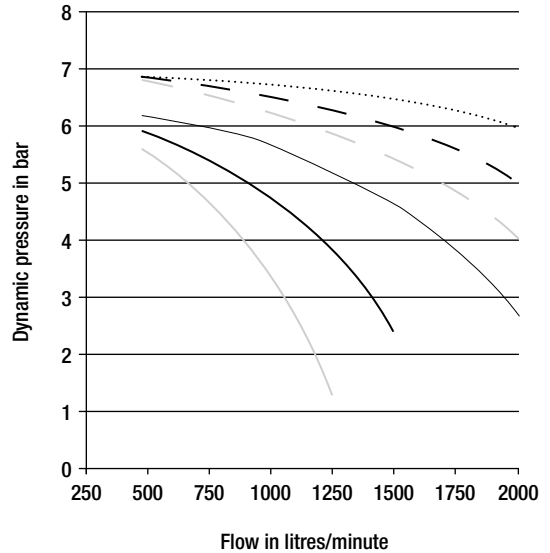

The graph to the right shows the pressure loss in a festoon system using a 1/2" or 3/8" compressed air hose at an operating pressure of 7 bar. The pressure loss from the traverse trolley to the consumer or the downstream systems must be added in each case.

- | | | | |
|-------|--|----|--|
| | 1/2" - hose length: 9 m
(6 m working range) | —— | 3/8" - hose length: 9 m
(6 m working range) |
| --- | 1/2" - hose length: 18 m
(12 m working range) | —— | 3/8" - hose length: 18 m
(12 m working range) |
| - - - | 1/2" - hose length: 27 m
(18 m working range) | —— | 3/8" - hose length: 27 m
(18 m working range) |

Festoon System – Components and Part Numbers

End Clamp

Part No.: 024312
Material: Steel, plastic



Cable Trolley with Ball Joint

Part No.: 024313-80
Material: Galvanized steel, plastic
Ball bearings, galvanized with ZZ seal
Load capacity: 20 kg



Cable Trolley with Bracket and Buffers

Part No.: 024320-125
Material: Galvanized steel
Ball bearings, galvanized with ZZ seal
Load capacity: 32 kg



Energy Supply

Festoon System – Components and Part Numbers

Cable holder for attachment to ball joint

Part No.: 020131-16 (for cable diameter 10 – 17 mm)

Part No.: 020131-25 (for cable diameter 17 – 25 mm)

Material: Cable holder: plastic
Connection elements: galvanized steel



For end clamp (048926) and cable trolley (048951) as well as for the attachment of a second cable/hose under cable holder 020131-16...25 and 020133-16...25

Cable holder for attachment to clips

Part No.: 020133-16 (for cable diameter 10 – 17 mm)

Part No.: 020133-25 (for cable diameter 17 – 25 mm)

Material: Cable holder: plastic
Connection elements: galvanized steel



For cable trolleys with hoop 048951-001. To be used for compressed air hoses > 3/8" or for multiple supply lines.

Electric Cables

Round Cable H05RR-F3G2.5 Round Cable H05RR-F5G2.5

Part No.:	0601-3G2,5#	0601-5G2,5#	
Outside diameter:	10.9 – 14 mm	13.3 – 17 mm	
Max. voltage:	430/750 V	430/750 V	
Strand count/conductor cross-section:	3 x 2.5 mm ²	5 x 2.5 mm ²	
Sheathing material:	Rubber	Rubber	
Protective conductor:	Yes	Yes	Other cables upon request

Compressed Air Hoses

Hose DN9 (3/8")

Hose DN13 (1/2")

Part No.:	040421-2	040421-3	
Part No. of hose clip:	040443-4	040443-6	
Part No. of hose clamp:	040435-20	040435-20	
Nominal pressure:	19 bar	16 bar	
Medium:	Compressed air	Compressed air	
Inner diameter:	9 mm	12 mm	
Outside diameter:	15 mm	21 mm	
Material:	PVC	PVC	Other hoses upon request

Festoon System – Layout Tips

If the festoon system requires special adjustment, please contact us directly. You can also find additional instructions in our catalogue 0240 "Festoon Systems for C-rails". The following rules of thumb apply for simple layout and quantity calculations:

- Number of end stops: 2 per cycle
- Number of end clamps: 1 per cycle
- Number of cable trolleys: Cycle length / 1.6
- Number of cable holders: Number of end clamps + number of cable trolleys (for two hoses/cables or a cable and a hose, this number must be doubled)
- Length of hose/cable: Cycle length x 1,25 + connection length

For this layout, a cable trolley depot of about 10% of the cycle length is also needed to buffer the trolleys. The cable slack is approx. 0.75 m.

Example:

4 cycles, each with a cycle length of 15 metres, should support one pneumatic and one electric energy supply each.

The connection lengths from the festoon system to the feed are each 2 m.

Number of end stops:	4 x 2 per cycle = 8 units
Number of end clamps:	4 x 1 per cycle = 4 units
Number of cable trolleys:	4 x 15 / 1.6 = 36 units
Number of cable holders:	(4 + 36) x 2 = 80 units
Number/length of hoses:	4 x (15 x 1,25 + 2) = 4 hoses of 20,75 m each
Number/length of cables:	4 x (15 x 1,25 + 2) = 4 cables of 20,75 m each

Energy Supply

Festoon System – Equipment Carrier

Part No.: 047254
Material: Steel, coated
Main roller: Steel
Load capacity [kg]: 50
Compressed air connection: 1 x G3/8"
Length [mm]: 500
Traverse color: RAL 1012, lemon yellow
Components: End Clamp with Cable Holder, 1 x Bracket



Part No.: 047255
Material: Steel, coated
Main roller: Steel
Load capacity [kg]: 50
Compressed air connection: 2 x G3/8"
Length [mm]: 500
Traverse color: RAL 1012, lemon yellow
Components: End Clamp with Cable Holder, 2 x Bracket, 2 x Reduction G3/8" to G1/4"



Part No.: 047281
Material: Steel, coated
Main roller: Steel
Load Capacity [kg]: 50
Compressed Air Connection: 1 x G3/8"
Electrical Connection: 1 x 230 V
Current load: 10/16 A
Length [mm]: 630
Traverse colour: RAL 1012, lemon yellow
Components: End Clamp with 2 x Cable Holder, 2 x Bracket, Reduction G3/8" to G1/4", Power Socket 230 V 10/16 A



Part No.: 047272
Material: Steel, coated
Main roller: Steel
Load Capacity [kg]: 50
Compressed Air Connection: -
Electrical Connection: 2 x 230 V
Current load: 10/16 A
Length [mm]: 630
Traverse colour: RAL 1012, lemon yellow
Components: End Clamp with Cable Holder, 2 x Bracket, Power Socket 2 x 230 V 10/16 A



Tool Transporter

General Information

Optimize your workstations with a customised tool transporter. This makes your tools, hardware and power easily accessible and close at hand without cable clutter and trip hazards. Your workstations become more ergonomic, safer and more economical.

We individually make your tool transporter for you and your application. We start with a base frame of aluminum groove profile, which you can customize to your individual working height using the option of height and width adjustment, and to the particular application.

You can put together your perfect tool transporter from a wide range of components. By virtue of the groove profile, these can be flexibly and quickly attached to the base frame. This also makes it easy to install additional components at a later date. Electrical and/or compressed-air connections can be integrated as desired.

The tool transporter can be rotated at will, so you can access your tools from any side. The tool transporter is supplied fully assembled with the requested components.

The carrying capacity of the tool transporter including its dead weight is 125 kg.

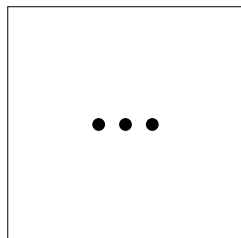

Accessories

Braking Skids

The braking skids are inserted between 2 runners in the C rail, thus preventing any unwanted movement in both directions. The braking skids do not completely brake the bars, but can be moved.

Part No.: 024784

Braking force: 1-2 [kN]

Material: Plastic

Connection elements: Galvanised Steel

Weight: 0.1 [kg]



Reels, Retractors, and Balancers

Whether for hoses or cables, as classical reels or high-precision positioning aids for tools – reels and retractors from Conductix-Wampfler take the load off your shoulders. You can find the complete product range in catalogue 0402-0002-E “Reels/Retractors/Balancers”, or online at www.conductix.com



Your Applications – our Solutions!

Workplace systems from Conductix-Wampfler represent only one of the many solutions made possible by the broad spectrum of Conductix-Wampfler components for the transport of energy, data and fluid media. The solutions we deliver for your applications are based on your specific requirements. In many cases, a combination of several different Conductix-Wampfler systems can prove advantageous. You can count on all of Conductix-Wampfler's Business Units for hands-on engineering support – coupled with the perfect solution to meet your energy management and control needs.



Cable reels

Motorized reels and spring reels by Conductix-Wampfler hold their own wherever energy, data and media have to cover the most diverse distances within a short amount of time - in all directions, fast and safe.



Festoon systems

It's hard to imagine Conductix-Wampfler cable trolleys not being used in virtually every industrial application. They're reliable and robust and available in an enormous variety of dimensions and designs.



Conductor rails

Whether they're enclosed conductor rails or expandable single-pole systems, the proven conductor rails by Conductix-Wampfler reliably move people and material.



Non-insulated conductor rails

Extremely robust, non-insulated conductor rails with copper heads or stainless steel surfaces provide the ideal basis for rough applications, for example in steel mills or shipyards.



Energy guiding chains

The "Jack of all trades" when it comes to transferring energy, data, air and fluid hoses. With their wide range, these energy guiding chains are the ideal solution for many industrial applications.



Slip ring assemblies

Whenever things are really "moving in circles", the proven slip ring assemblies by Conductix-Wampfler ensure the flawless transfer of energy and data. Here, everything revolves around flexibility and reliability!



Inductive Power Transfer IPT®

The no-contact system for transferring energy and data. For all tasks that depend on high speeds and absolute resistance to wear.



Reels, retractors and balancers

Whether for hoses or cables, as classical reels or high-precision positioning aids for tools, our range of reels and spring balancers take the load off your shoulders.



Jib booms

Complete with tool transporters, reels, or an entire media supply system – here, safety and flexibility are key to the completion of difficult tasks.



Conveyor systems

Whether manual, semiautomatic or with Power & Free – flexibility is achieved with full customization concerning layout and location.

www.conductix.com

Conductix-Wampfler

has just one critical mission:

To provide you with energy and data transmission systems that will keep your operations up and running 24/7/365.

To contact your nearest sales office, please refer to:

[www.conductix.com/
contact-search](http://www.conductix.com/contact-search)



DELACHAUX GROUP