

Besta[®] Power Compressed Air and Electric Supply System

Program W⁵-traxX



CONDUCTIX
wampfler

Ⓞ DELACHAUX GROUP

Table of Contents

Overview	4
Product Description	4
Technical Specifications	4
Load Diagram (Point Load)	4
System Overview	5

Rail Components	6
Rail Lengths and Compressed-Air Outlets	6
Rail Connector	7
End Feed	7
End Cap	8
End Stop	8
Compressed-Air Outlet	8
Suspensions	9
Fastening Concept	9

Energy Supply	11
Energy Guiding Chains	12
Chain Kit with Supply Lines	12
Guiding Channels	13
Festoon Systems	14
Components and Order Numbers	14
Layout Hints	15

Trolleys	16
Trolleys	16
Single Trolleys	16
Traverse Trolleys	16
Tool Transporters	17

Accessories	18
Spare Parts Kit	18
Reels and Retractors	18

Overview

Product Description

The BestaPower W⁵-traxX energy supply system integrates the compressed air line in its aluminium load rail and provides mobile consumers with a continuous supply of compressed air, electrical energy, and data through an energy guiding chain or festoon system. The modular assembly and flexible attachment system allow for simple and quick installation as well as flexible upgrades or modifications. The double O-ring seals and compressed air outlets provide maximum flexibility, dependability and tightness. Standard fall protection on the trolleys and screw joint retention using thread locking coating provide the highest level of safety.

The main features of the BestaPower W⁵-traxX:

- Loading capacity: 100 kg with a maximum suspension interval of 4 m
- Integrated 2" compressed air pipe
- Standard 1/2" compressed air outlets every 2 m
- Flexible attachment of components provided by clamping profiles on all sides
- Simple, fast maintenance of trolleys and cleaning of rails due to outside runners
- Secure and simple guiding with flanged rim wheels
- Standard fall protection on trolleys

Technical Specifications

Loading capacity/suspension interval:	100 kg point loading at 4 m intervals (see graph below)
Load profile surface:	Anodized aluminium
Maximum operating pressure:	12 bar
Medium:	dry, cleaned and oiled compressed air
Usage location:	Indoors
Process temperature:	+5°C to +60°C
Feed:	2" ball valve with external threading
Integrated compressed air pipe:	2" inner diameter
Outlet:	1/2" ball valve with internal threading every 2000 mm
Energy feed:	Energy guiding chain, festoon system
Trolleys:	Standard trolleys (length: 400, 600, 800 mm) Standard fall protection Polyamide flanged rim wheels Custom trolleys and tool transporters on request

Load Diagram (Point Load)

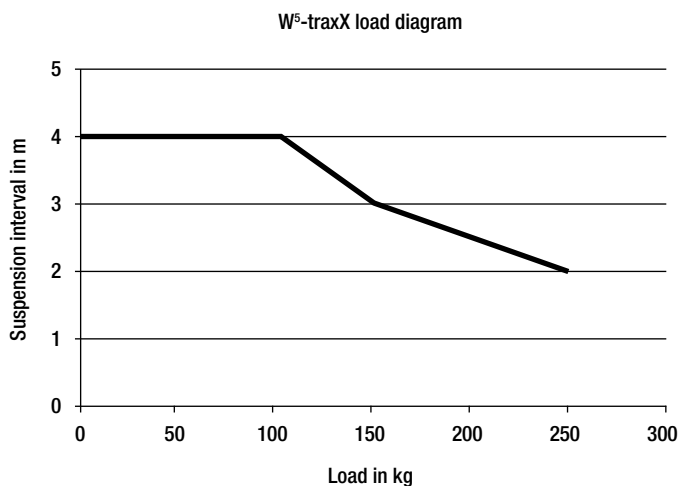

The graph shows the suspension intervals for a maximum deflection of 1/500 of the suspension interval. Heavier loads are possible, but the maximum deflection of 1/500 of the suspension interval will be exceeded.

In addition to the load capacity of the rails, the load capacity of the trolleys must also be considered.

Overview

System Overview

Within the rail components, besides the rail the following components are also available:

1. End feed
2. Suspension clamp
3. Rail connector
4. End cap
5. Compressed air outlet
6. End stop

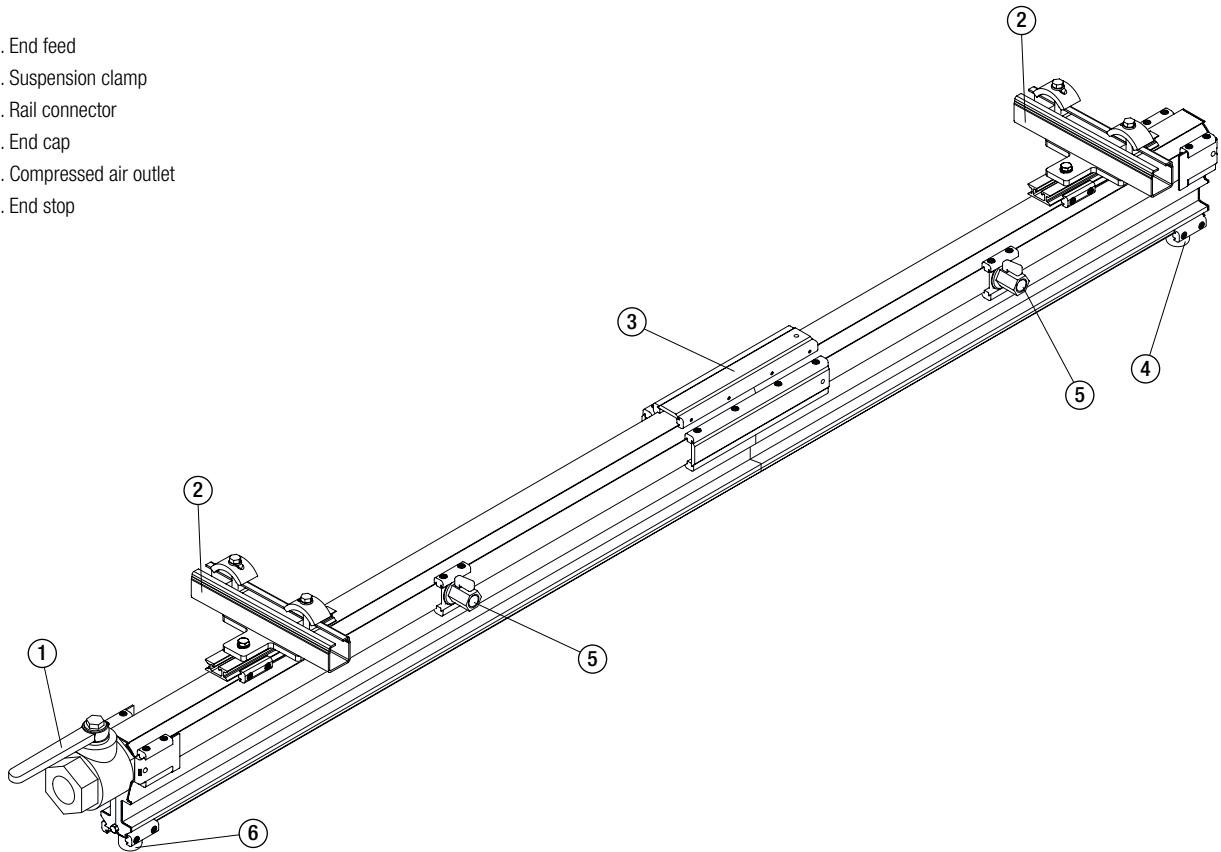

There are two different energy supply systems available for the W⁶-traxX profile:

Energy Guiding Chain

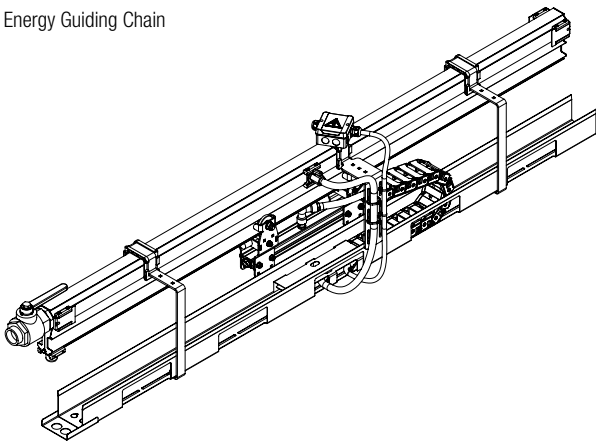

Festoon System

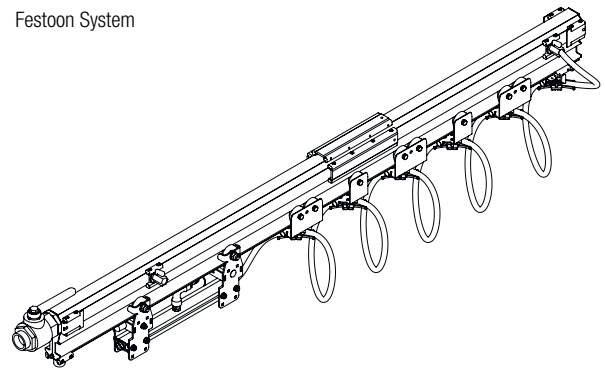

Rail Components

General Information

The W⁵-traxX rail is a compact aluminium load rail for stationary and continuous energy supply that has been specifically designed to meet the requirements of mechanical handling and assembly.

The integrated 2" compressed air tube provides for minimal pressure loss, allowing for economical compressed air delivery to the entire workspace.

Material: Anodized aluminium
Dimensions: 152 x 70 mm
Single profile length: max. 6000 mm (see table below)
Running surface: I-beam
Attachment: Dovetail clamps on all sides, adaptable t-notch 20 x 7 mm

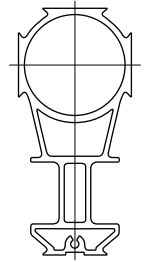

The individual rails can be joined using the double-sealed rail connector to create any system length.

Rail Lengths and Compressed Air Outlets

The standard configuration provides pre-assembled compressed air outlets with 1/2" mini ball valves at two meter intervals. The exact measurements for various rail lengths can be found in the following table:

Part No.	Length [mm]	Out-puts	L1 [mm]	L2 [mm]	L3 [mm]
048901-001-6,0	6000	3	1000	3000	5000
048901-001-4,0	4000	2	1000	3000	-
048901-001-2,0	2000	1	1000	-	-

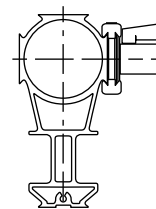
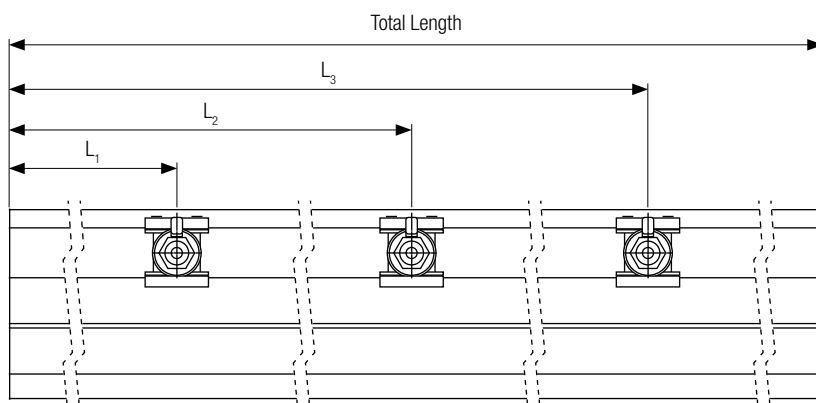
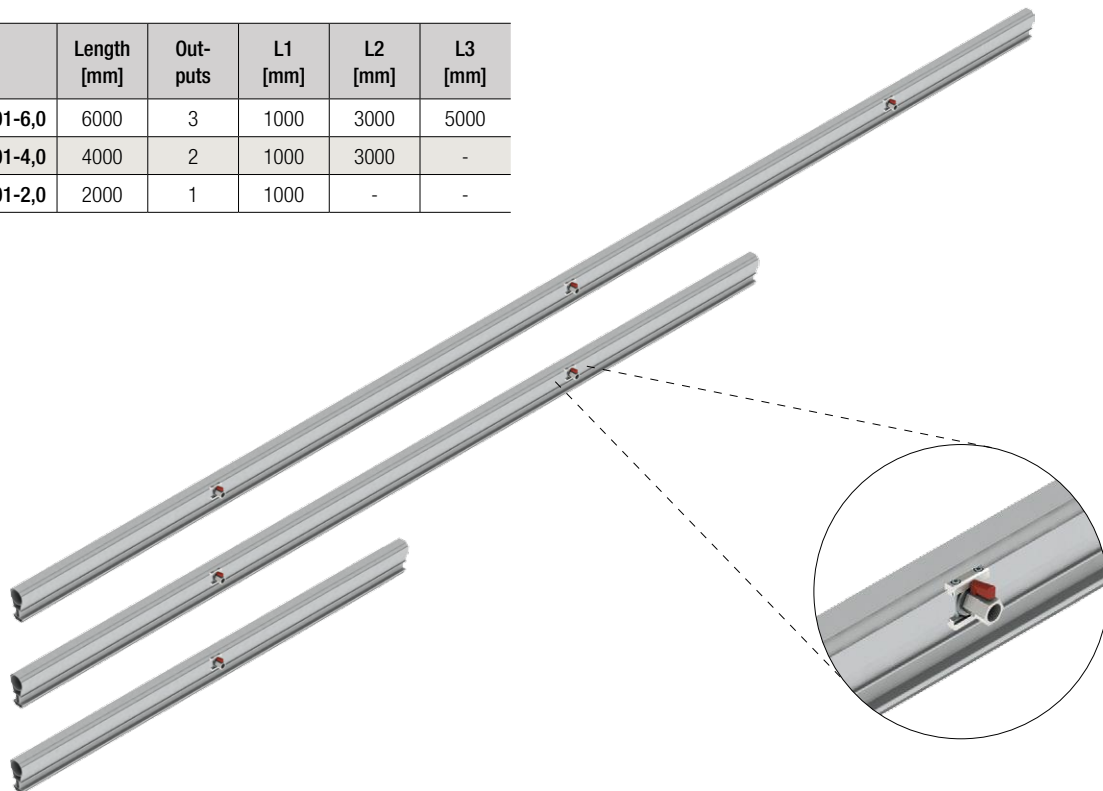

Outlet interface:
 ball valve with 1/2" internal threading
 Other special rails are available upon request.

Rail Components

Rail Connector

Part No.: 048915

The rail connector serves to connect two rails endwise. It is used to create longer systems. The joint is sealed with double O-rings on both sides to allow for maximal tightness.

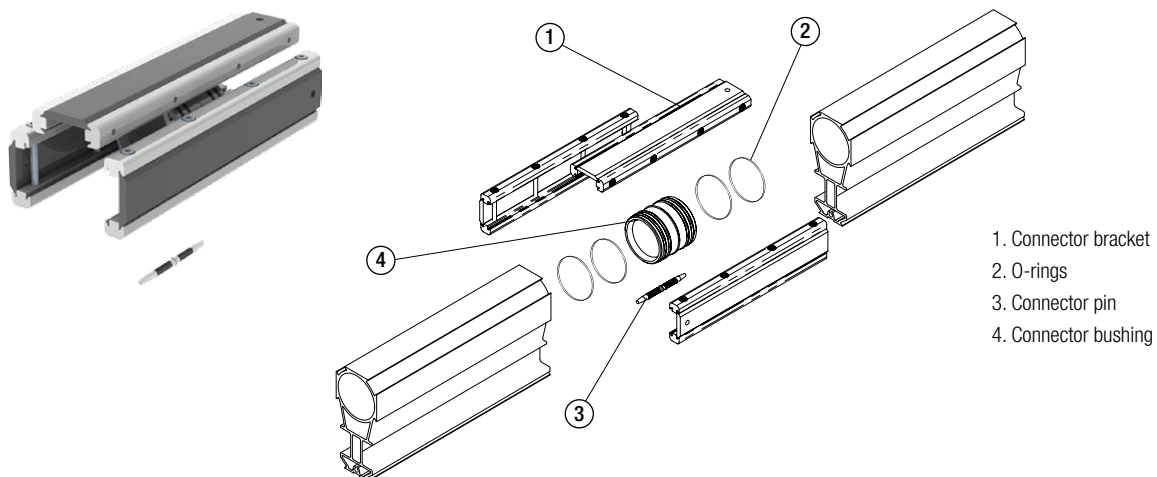

Rail End Feeds

Part No.: 048913

The standard interface for compressed air input is a ball valve (DN50) with G 2" external threading. A double O-ring seal and a safety notch pin guarantee tightness and operational safety.

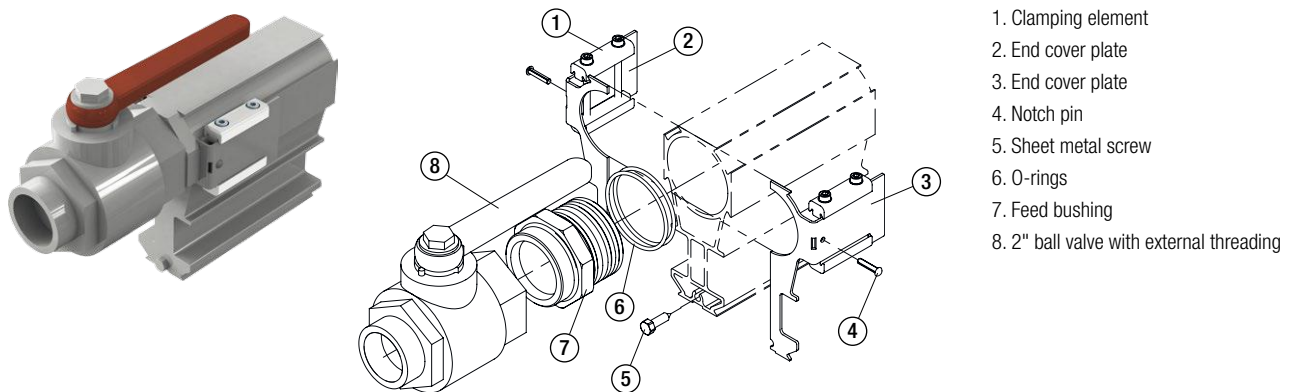

Rail Components

End Cap

Part No.: 048910

The end of the aluminium rail is closed with double-sealed end caps. A double O-ring seal and a safety notch pin guarantee tightness and operational safety.

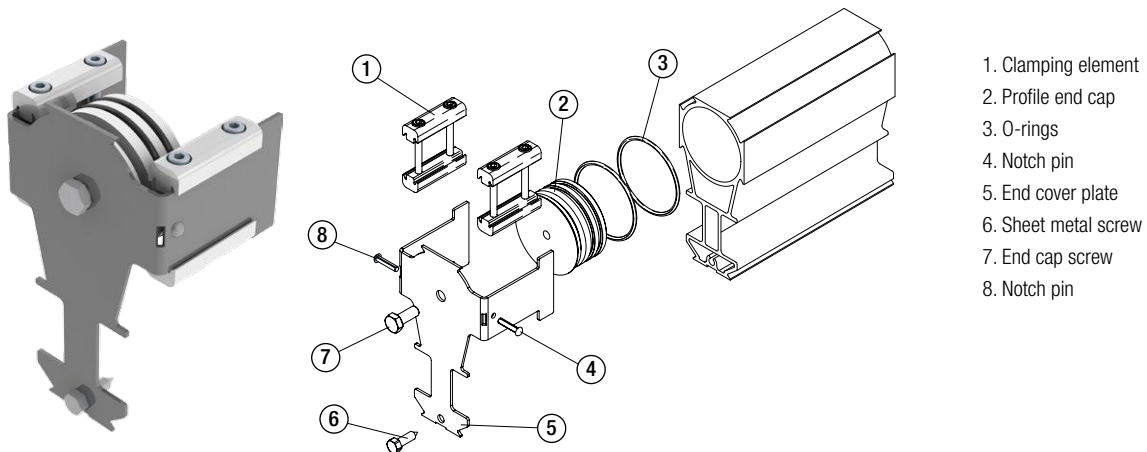

1. Clamping element
2. Profile end cap
3. O-rings
4. Notch pin
5. End cover plate
6. Sheet metal screw
7. End cap screw
8. Notch pin

End Stop

Part No.: 048925

The end stop for the BestaPower W⁶-traxX serves to limit the workspace and is necessary for the use of trolleys. The end stops can be positioned at any point along the rail using a clamping system.

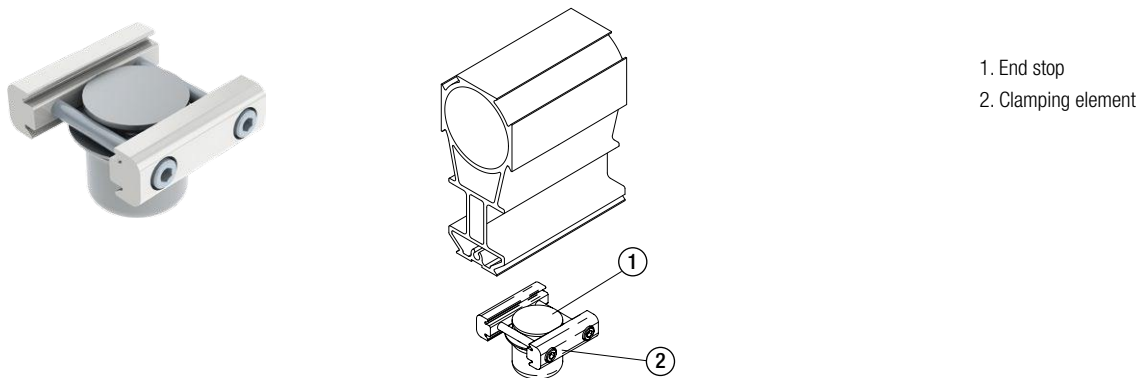

1. End stop
2. Clamping element

Compressed Air Outlet

Part No.: 048920-001

The interface for compressed air supply to the consumer uses a 1/2" mini ball valve with internal threading. The compressed air outlet is attached to the rail with a clamping element and is sealed with an O-ring. The standard profile configuration is delivered with compressed air outlets at two meter intervals.

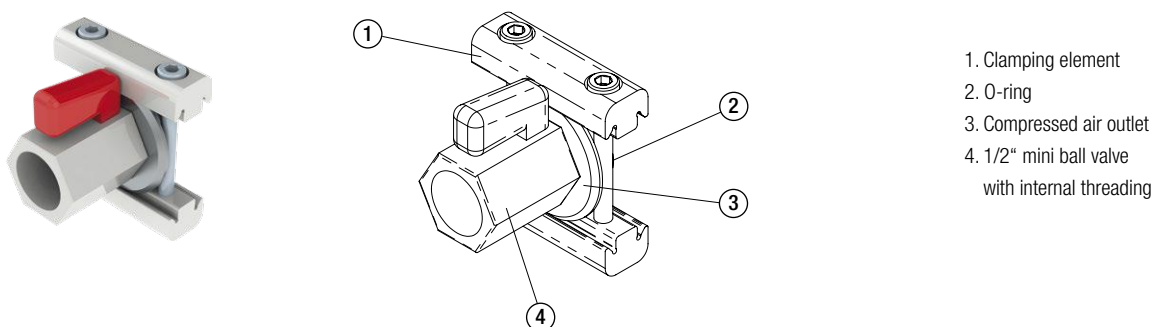

1. Clamping element
2. O-ring
3. Compressed air outlet
4. 1/2" mini ball valve with internal threading

Rail Components

Suspensions

Various suspension devices are available for attachment to existing steel beams at the customer's facility. Solutions are available for both parallel and transverse steel beam arrangements.

For transverse I-beams:

Part No.: 048960-001

Up to IPE 200. Other sizes on request

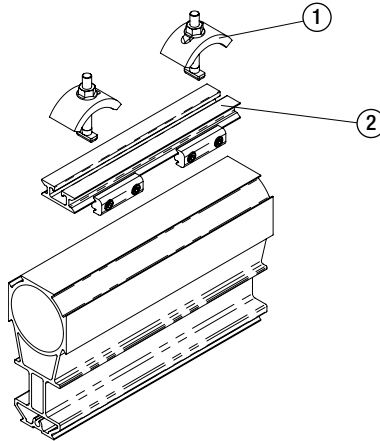
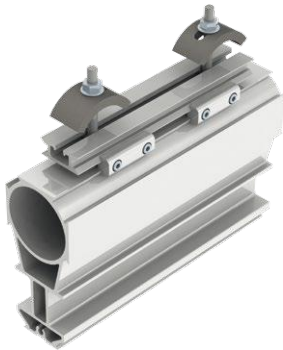

- 1. Clamping bracket
- 2. Fastening unit

For parallel I-beams:

Part No.: 048960

Up to IPE 240. Other sizes on request

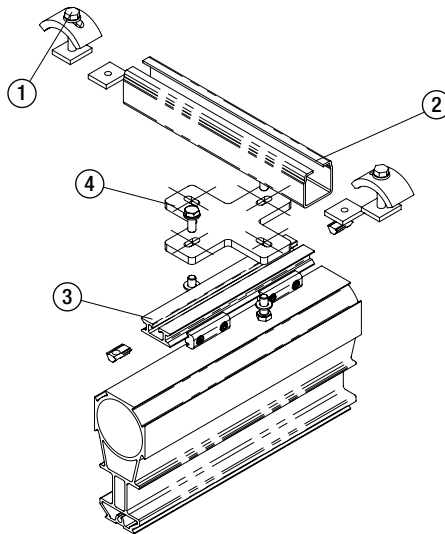

- 1. Clamping bracket
- 2. Support arm
- 3. Clamping unit
- 4. Cross plate

Attachment Concept

Using universal clamping brackets with a dovetail connection, additional components can be added to the side, the top or the bottom at any time. The interface used here is a universal clamping unit and T-slot nuts. The length of the fastening unit can be selected on a customer-specific basis.



Part No.:

04-A003-0304 universal clamping unit

04-3121716 T-slot nut, pivoting M4 (10 units)

04-162871 T-slot nut, pivoting M6 (10 units)

04-162872 T-slot nut, pivoting M8 (10 units)

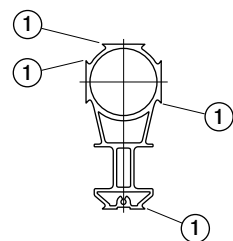
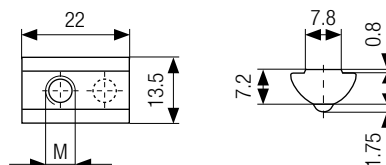

- 1. Possible locations on the load profile for adding components



Energy Supply

General









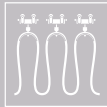

There are two different energy supply systems available for the W⁵-traxX system. These free workplaces from cables and hoses and guide energy to mobile consumers without restriction.

Both systems are suitable for the supply of electric and pneumatic energy as well as data transmission.

With the festoon system, the cables and/or hoses are attached to special cable trolleys, which are in turn guided along the rails. This permits the cables/hoses to be guided safely along rails overhead.

With the energy guiding chain, the cables and hoses are arranged compactly and safely within a chain. The "reeling out and in" of the chain allows energy to be guided wherever it is needed.

The two systems differ in various characteristics:

	Festoon System	Energy Guiding Chain
		
Advantages / Features		
Pneumatic Energy Supply		
Electrical Energy Supply		
No Restoring Forces		
No Cable Loops		
Full use of the Workspace		
Simple Service and Conversion		
Pressure Loss Factor *	3	1
Installation Time Factor *	3	2

* 1 = very low 2 = average 3 = considerable

Energy Supply

Energy Guiding Chain

The energy guiding chain permits continuous energy supply throughout the workspace. In addition to compressed air hoses, electric and data lines can be safely guided to the consumer.

1. Guiding channel
2. Traversing plate
3. Feeding bracket
4. Chain kit with supply lines

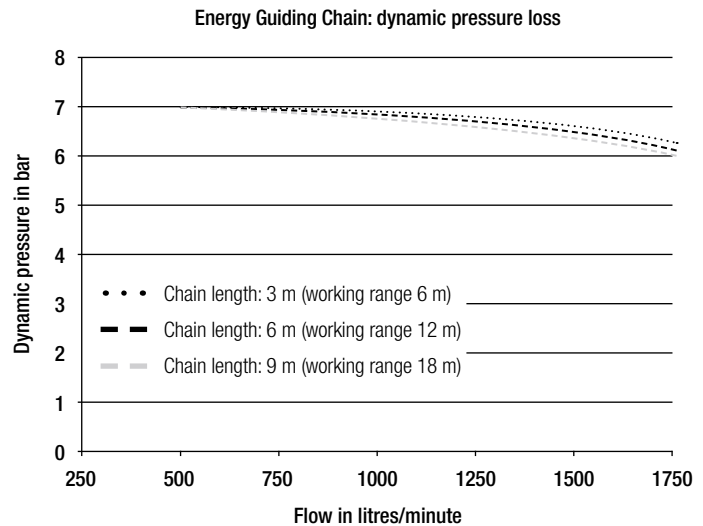
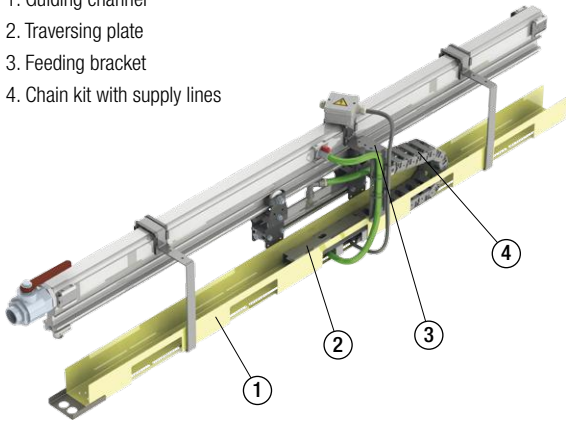

The use of energy guiding chains frees the area around the worker's head from distracting cable slack.

The energy guiding chain, fed at the centre of the cycle, allows for more efficient use of compressed air than with normal festoon or spiral hose systems, as shorter hoses can be used.

The graph above shows the pressure loss of an energy guiding chain using a 1/2" compressed air hose at an operating pressure of 7 bar.

The pressure loss from the traverse trolley to the consumer or the downstream systems must be added to this in each case.

Energy Guiding Chain – Chain Kit with Supply Lines

In general, a chain kit includes the energy guiding chain with supply lines and the necessary elements to attach the energy guiding chain. Depending on the supply line, the energy guiding chain allows a later elongation. Standard chain kits can be custom-configured with respect to length and desired supply lines.

Part No.: 048935#

Length:	Chain is adjusted to fit the cycle
Possible supply lines:	Compressed air hose with 1/2" inner diameter
	Electric cable: 3 x 2.5 mm ² or 5 x 2.5 mm ²
	Data lines and other supply line options upon request

Technical features of chains

Outside measurements, chain:	79 x 35 mm
Inside measurements, chain:	62 x 26 mm
Minimum bending radius:	70 mm
Material:	PA

Possible components:

- Traversing plate
- 1/2" hose and/or electric cable
- Hose/cable connection length is configurable and can be cut to fit during installation
- For electric cable: terminal boxes with mounting material
- Accessories for attaching the energy guiding chain



Energy Supply

Energy Guiding Chain – Guiding Channel

The guiding channels carry and guide the chain kit. The number of guiding channels needed is based on the cycle length. The channels are connected endwise using a connection plate.

Mounting on aluminium rail is quick and simple without screws, instead using plastic (polyamide) fastening clips.

For fast-moving chains, a guide plate can optionally be attached to the bracket as a rise limiter (not shown).

Part No.:

3-meter length: **048930-3,0**

2-meter length: **048930-2,0**

1-meter length: **048930-1,0**

Material: powder coated steel

Colour: yellow (guiding channel), anthracite/black (attachment).

Other colours available on request.

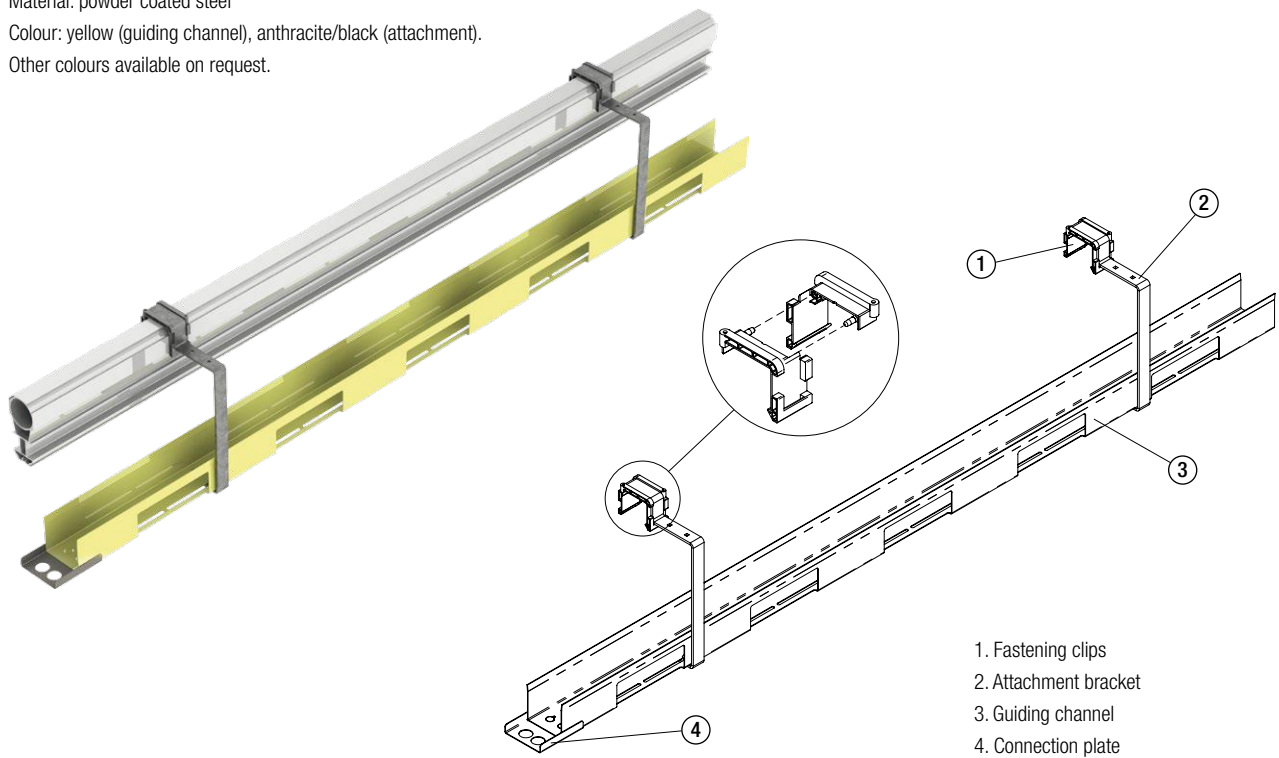

In addition to the guiding channel, a feeding bracket is also available. This is mounted on the rail next to the feed point of the energy guiding chain.

Hoses and cables can be attached to the feeding bracket to guide them to the feed point.

Part No.: 04-S089-0352



Energy Supply

Festoon System

For short to medium cycle lengths and low compressed air usage, a festoon system is another possible alternative.

1. Cable trolley
2. End clamp
3. Cable/hose
4. Cable holder
5. End stop

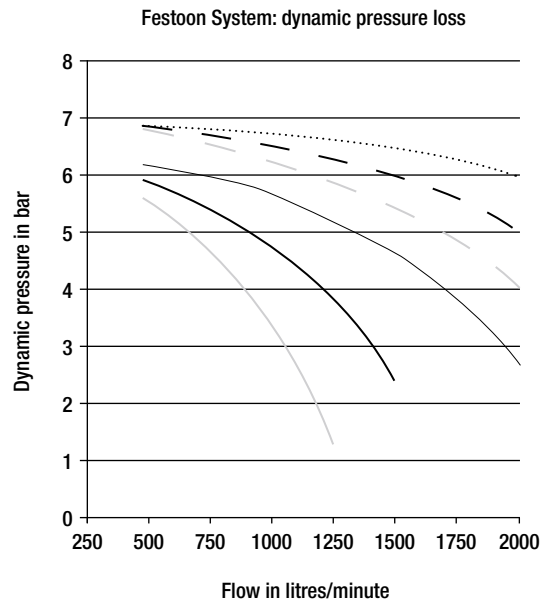
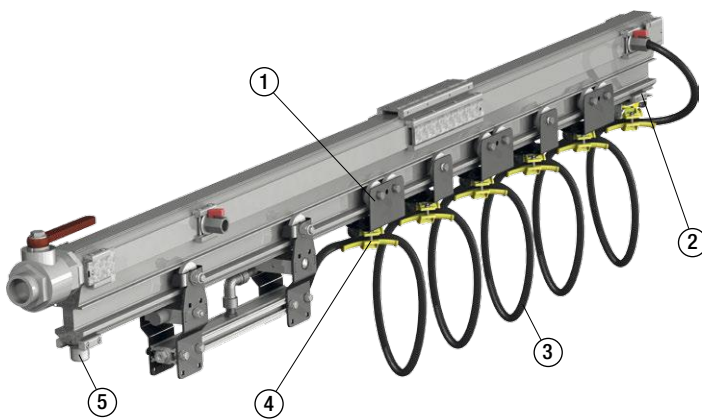

The graph to the right shows the pressure loss in a festoon system using a 1/2" or 3/8" compressed air hose at an operating pressure of 7 bar. The pressure loss from the traverse trolley to the consumer or the downstream systems must be added in each case.

- | | | | |
|-------|--|----|--|
| | 1/2" - hose length: 9 m
(6 m working range) | —— | 3/8" - hose length: 9 m
(6 m working range) |
| - - - | 1/2" - hose length: 18 m
(12 m working range) | —— | 3/8" - hose length: 18 m
(12 m working range) |
| - - - | 1/2" - hose length: 27 m
(18 m working range) | —— | 3/8" - hose length: 27 m
(18 m working range) |

Festoon System – Components and Order Numbers



End Clamp W⁵-traxX

Part No.: 048926

Length of end clamp: 108 mm

Material: End clamp: epoxy-coated steel. Connector plate: plastic



Cable Trolley

Part No.: 048951

Trolley length: 120 mm

Material: Cable trolleys: epoxy-coated steel. Flanged rim wheels: PA



Cable Trolley with hoop

Part No.: 048951-001

Trolley length: 120 mm

Material: Cable trolleys: epoxy-coated steel. Flanged rim wheels: PA. Clips: galvanized steel

Energy Supply

Festoon System – Components and Order Numbers



Cable holder for attachment to ball joint

Part No.: 020131-16 (for cable diameter 10 – 17 mm)

Part No.: 020131-25 (for cable diameter 17 – 25 mm)

Material: Cable holder: plastic
Connection elements: galvanized steel

For end clamp (048926) and cable trolley (048951) as well as for the attachment of a second cable/hose under cable holder 020131-16...25 and 020133-16...25



Cable holder for attachment to clips

Part No.: 020133-16 (for cable diameter 10 – 17 mm)

Part No.: 020133-25 (for cable diameter 17 – 25 mm)

Material: Cable holder: plastic
Connection elements: galvanized steel

For cable trolleys with hoop 048951-001. To be used for compressed air hoses > 3/8" or for multiple supply lines.

Electric Cables

Round Cable H05RR-F3G2.5

Round Cable H05RR-F5G2.5

Part No.:	0601-3G2,5#	0601-5G2,5#	
Outside diameter:	10.9 – 14 mm	13.3 – 17 mm	
Max. voltage:	430/750 V	430/750 V	
Strand count/conductor cross-section:	3 x 2.5 mm ²	5 x 2.5 mm ²	
Sheathing material:	Rubber	Rubber	
Protective conductor:	Yes	Yes	Other cables upon request

Compressed Air Hoses

Hose DN9 (3/8")

Hose DN13 (1/2")

Part No.:	040421-2	040421-3	
Part No. of hose clip:	040443-4	040443-6	
Part No. of hose clamp:	040435-20	040435-20	
Nominal pressure:	19 bar	16 bar	
Medium:	Compressed air	Compressed air	
Inner diameter:	9 mm	12 mm	
Outside diameter:	15 mm	21 mm	
Material:	PVC	PVC	Other hoses upon request

Festoon System – Layout Tips

The following rules of thumb apply for simple layout and quantity calculations:

- Number of end stops: 1 per cycle
- Number of end clamps: 1 per cycle
- Number of cable trolleys: Cycle length / 1.6
- Number of cable holders: Number of end clamps + number of cable trolleys (for two hoses/cables or a cable and a hose, this number must be doubled)
- Length of hose/cable: Cycle length x 1.25 + connection length

For this layout, a cable trolley depot of about 10% of the cycle length is also needed to buffer the trolleys.

Example:

4 cycles, each with a cycle length of 15 metres, should support one pneumatic and one electric energy supply each.

The connection lengths from the festoon system to the feed are each 2 m.

Number of end stops:	4 x 1 per cycle = 4 units
Number of end clamps:	4 x 1 per cycle = 4 units
Number of cable trolleys:	4 x 15 / 1.6 = 36 units
Number of cable holders:	(4 + 36) x 2 = 80 units
Number/length of hoses:	4 x (15 x 1.25 + 2) = 4 hoses of 20.75 m each
Number/length of cables:	4 x (15 x 1.25 + 2) = 4 cables of 20.75 m each

The cable slack for this layout is about 0.75 m.

If the festoon system requires special adjustment, please contact us directly. You can also find additional instructions in our catalogue 0240 "Festoon Systems for C-rails".

Trolleys

Trolleys

BestaPower W⁵-traxX allows various types of trolleys to be used for different applications. Single and traverse trolleys are the interfaces for energy guiding chains and festoon systems.

The trolleys of the BestaPower W⁵-traxX are designed to be extremely soft-running. Thanks to the innovative aluminium load rail, flanged rim wheels can be used that serve as guide rollers as well as counter-pressure rollers.

End stops are required for trolley use in order to limit the cycle length.

Feature summary of the BestaPower W⁵-traxX trolleys at a glance:

- Soft running thanks to polyamide (PA) flanged rim wheels
- Highest level of security thanks to standard fall protection
- Interfaces for energy feeds
- Very flexible, thanks to customer-specific combinations with traverses, tool transporters, load trolley
- Soft stop with rubber buffers

Single Trolley

Part No.: 048950

Loading capacity: max. 50 kg

Rollers: Polyamide flanged rim wheels

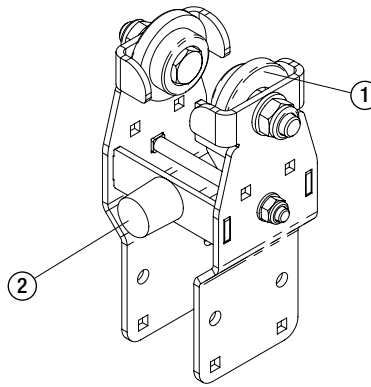
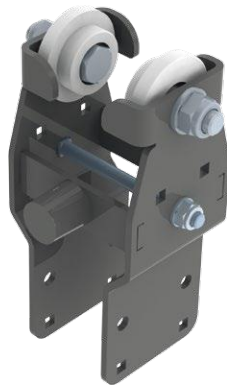

1. Flanged rim wheel

2. Rubber buffer

Traverse Trolley

Part No.: 048955-0460

BestaPower W⁵-traxX traverse trolleys offer infinite possibilities for use at assembly workstations. A compressed air distributor is integrated into the aluminium traverse so that all applications can be optimally supplied.

Loading capacity: max. 100 kg

Rollers: Polyamide flanged rim wheels

Traverse length: 400 mm (standard); 600 mm, 800 mm, customer-specific

Compressed air interfaces: 1 pivoting 1/2" feed for items such as the chain module

2 x 1/2" outlets (equipped with plugs)

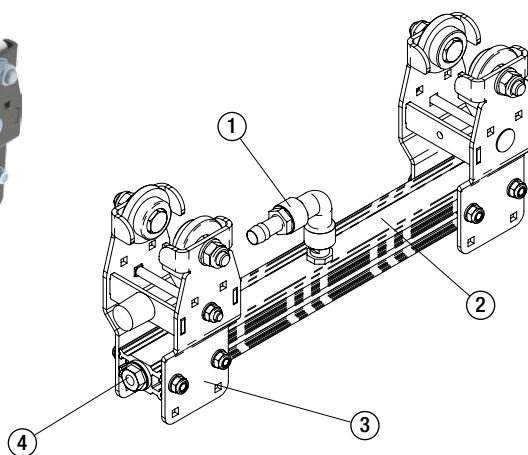
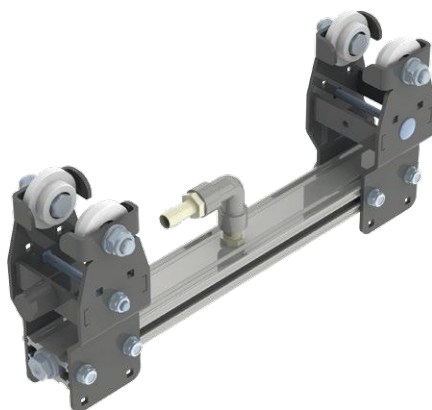

1. 1/2" feed for items such as the chain module

2. Traverse with integrated compressed air distributor

3. Single trolley

4. Blind plug

Trolleys

Tool Transporter

Optimise your production with the W⁵-traxX system in combination with a custom-dimensioned transporter. You'll always have your tools, small parts and energy feed at hand nearby, without any cable clutter or risk of stumbling. Your workstations will be more ergonomic, safer and more economical.

We will custom-build your tool transporter for you and your application. We'll start with a base frame of aluminium slot profile which you can adjust to your individual working height and the specific application with optional height and width adjustments.

You can put together your optimum tool transporter from a wide variety of components. The slot profile makes them flexible and easy to attach to the base frame. This also makes the later addition of more components easy. Electrical and/or compressed air connections are already integrated as requested. The tool transporter can be made to turn as needed so you can get to your tools from any side. The tool transporter with all the components you order is delivered fully assembled. The loading capacity of the tool transporter, including its own weight, is 100 kg.

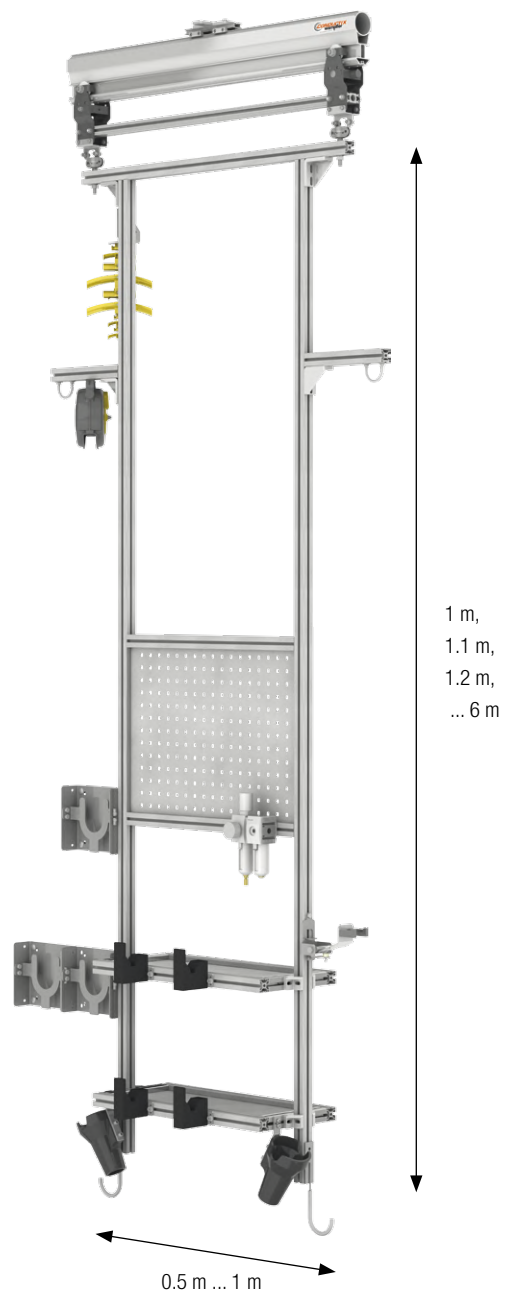
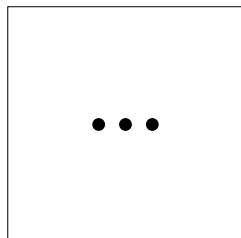

Accessories

Spare Parts Kit

Part No.: 048965

The spare parts kit includes an assortment of spare parts and accessories, and is particularly useful in case of larger W⁵-traxX projects. Individual components are available upon request. The W⁵-traxX spare parts kit includes the following components:

10 units	T-slot nut, pivoting M8
10 units	M8 x 60 hammerhead bolt with flanged nut
5 units	O-ring, 58.42 x 2.62 NBR 70
5 units	O-ring, 23.00 x 2.50 NBR 70
1 unit	Feed, G 2" external threading
10 units	Notch pin, DIN1476-04x020, galvanized
2 units	W ⁵ -traxX holder set
2 units	W ⁵ -traxX clamp
10 units	Round-head screw, DIN603-M6 x 16-4.6, galvanized
1 unit	Connector pin
5 units	Clamping bracket
1 unit	W ⁵ -traxX end stop
4 units	Connector screw, 1/2" external threading
1 unit	Slot profile, L = 6000 mm

Reels, Retractors, and Balancers

Whether for hoses or cables, as classical reels or high-precision positioning aids for tools – reels and retractors from Conductix-Wampfler take the load off your shoulders. You can find the complete product range in catalogue 0402-0002-E "Reels/Retractors/Balancers", or online at www.conductix.com



Your Applications – our Solutions!

Workplace systems from Conductix-Wampfler represent only one of the many solutions made possible by the broad spectrum of Conductix-Wampfler components for the transport of energy, data and fluid media. The solutions we deliver for your applications are based on your specific requirements. In many cases, a combination of several different Conductix-Wampfler systems can prove advantageous. You can count on all of Conductix-Wampfler’s Business Units for hands-on engineering support – coupled with the perfect solution to meet your energy management and control needs.



Cable reels

Motorized reels and spring reels by Conductix-Wampfler hold their own wherever energy, data and media have to cover the most diverse distances within a short amount of time - in all directions, fast and safe.



Festoon systems

It’s hard to imagine Conductix-Wampfler cable trolleys not being used in virtually every industrial application. They’re reliable and robust and available in an enormous variety of dimensions and designs.



Conductor rails

Whether they’re enclosed conductor rails or expandable single-pole systems, the proven conductor rails by Conductix-Wampfler reliably move people and material.



Non-insulated conductor rails

Extremely robust, non-insulated conductor rails with copper heads or stainless steel surfaces provide the ideal basis for rough applications, for example in steel mills or shipyards.



Energy guiding chains

The “Jack of all trades” when it comes to transferring energy, data, air and fluid hoses. With their wide range, these energy guiding chains are the ideal solution for many industrial applications.



Slip ring assemblies

Whenever things are really “moving in circles”, the proven slip ring assemblies by Conductix-Wampfler ensure the flawless transfer of energy and data. Here, everything revolves around flexibility and reliability!



Inductive Power Transfer IPT®

The no-contact system for transferring energy and data. For all tasks that depend on high speeds and absolute resistance to wear.



Reels, retractors and balancers

Whether for hoses or cables, as classical reels or high-precision positioning aids for tools, our range of reels and spring balancers take the load off your shoulders.



Jib booms

Complete with tool transporters, reels, or an entire media supply system – here, safety and flexibility are key to the completion of difficult tasks.

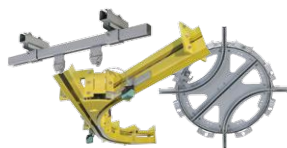

Conveyor systems

Whether manual, semiautomatic or with Power & Free – flexibility is achieved with full customization concerning layout and location.

www.conductix.com

Conductix-Wampfler

has just one critical mission:
To provide you with energy and
data transmission systems that
will keep your operations up
and running 24/7/365.

To contact your nearest
sales office, please refer to:

[www.conductix.com/
contact-search](http://www.conductix.com/contact-search)



DELACHAUX GROUP