

Overhead Monorail Systems

Program 1400

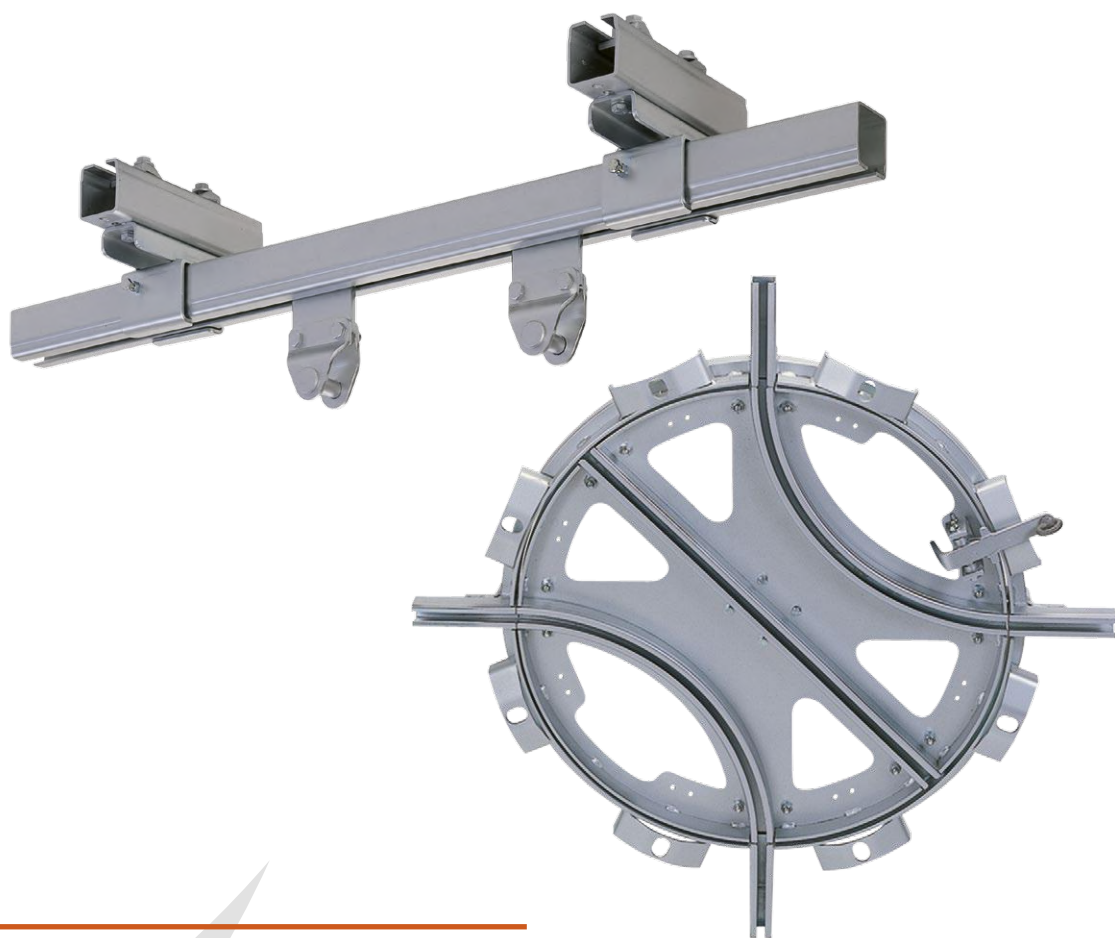

CONDUCTIX
wampfler

Ⓞ DELACHAUX GROUP

Safety Warnings



WARNING!

Danger to life from suspended loads!

Falling loads can cause serious bodily harm or even death. Therefore:

- Never step under suspended loads.
- Do not move suspended loads unsupervised.

Use in accordance with regulations:

Overhead Monorail Systems in this catalog are manufactured according to the state of the art. However, when not used in accordance with regulations, threat to life or physical condition of the user or third parties and/or damage to the facility or other tangible assets can occur.

The following uses are in accordance with regulations:

- Transporting general cargo
- Manual traversing or traversing by using drag chain conveyors from Conductix-Wampfler
- Indoor usage

The following uses are not in accordance with regulations:

- Mechanical coupling with electrically driven machinery (except for designated drag chain conveyors from Conductix-Wampfler)
- Exceeding permissible load limits
- Exceeding permissible travel speeds
- Installing hoisting devices or other machinery which place additional forces onto the Overhead Monorail System
- Stepping under suspended loads
- Transporting people
- Operating the Overhead Monorail System with unauthorized accessories
- Operating the Overhead Monorail System outdoors
- Installing the Overhead Monorail System on an insufficient steel structure

Contents

System Description	5
Overhead Monorail System Example	5
Standard Components	6
C-Rails	7
Curves	8
Selecting Curves	8
Curves 90°	8
Curves 45°	9
Rail Support Brackets and Rail Couplers	10
Rail Support Brackets – Basic Design	10
Rail Couplers – Basic Design	10
Rail Support Brackets – with Crosshead	11
Rail Couplers – with Crosshead	11
Rail Support Brackets – with Screw	12
Rail Couplers – with Screw	12
Rail Support Brackets – with Support Arm	13
Rail Couplers – with Support Arm	13
Rail Support Brackets – Two-piece	14
Rail Couplers – Two-piece	14
Combined Rail Support Brackets and Rail Couplers	15
Girder Clips	16
Girder Clips M8	16
Girder Clips M10 and M12	16
End Stops	17
for C-Rails 40 x 40 up to 80 x 80	17
Suspensions for Monorail Systems	18
Single-point Suspensions	18
V-shaped Suspensions	18
Switches	20
Accessories for Point Switches	28
S-Green Wear Pads	28
Turning Switches	29
Suspension Trolleys	30
Two Rollers – to weld on	30
Two Rollers – Standard	31
Two Rollers – with Ring Nut	31
Four Rollers – to weld on	32
Four Rollers – Standard	32
Four Rollers – with Ring Nut	33
Four Rollers – for increased Loads	33
For Load Hooks	34
Suspension Trolleys with horizontal Guiding Rollers	35

Traverse Trolleys	36
Four Rollers – without Detent	36
Four Rollers – with Detent	37
Four Rollers – with Eyelet	38
Two Rollers – with Traverse	39
Four Rollers – with Traverse	40
Latches	41
Single-acting Latches	41
Latches with individual release	41
Back-Stops	41
Swivel Guides	42
Drag Chain Conveyors	42
Transfer Bridges with Latching Devices	43
Arresters	44
Lifting and Lowering Stations	45
Project Planning	46
Rail Suspension	46
Choosing Suspension Trolleys	46
Determining the valid Suspension Spacing	47
Load Diagram	47
Permissible Travel Speed	48

Overhead Monorail Systems Program 1400

General

For in-plant transport of materials, Conductix-Wampfler offers customized modular conveyor systems that provide optimal material flow. Several additional components, such as switches, curves, etc., allow the creation of complex system layouts. By using a modular system with a basic setup, Overhead Monorail Systems can be designed and employed for many different applications.

Advantages of Conductix-Wampfler Overhead Monorail Systems:

- Low investment costs
- Reduced transport times within the facility
- Reduced handling times
- Increased productivity
- Ergonomic operation for workers
- Targeted material flow
- Product-related design
- Ability to extend the system anytime
- Individual expansion with customized designs
- Flexible adaption if production conditions change
- Easy planning with a clearly structured modular system

Overhead Monorail System Example

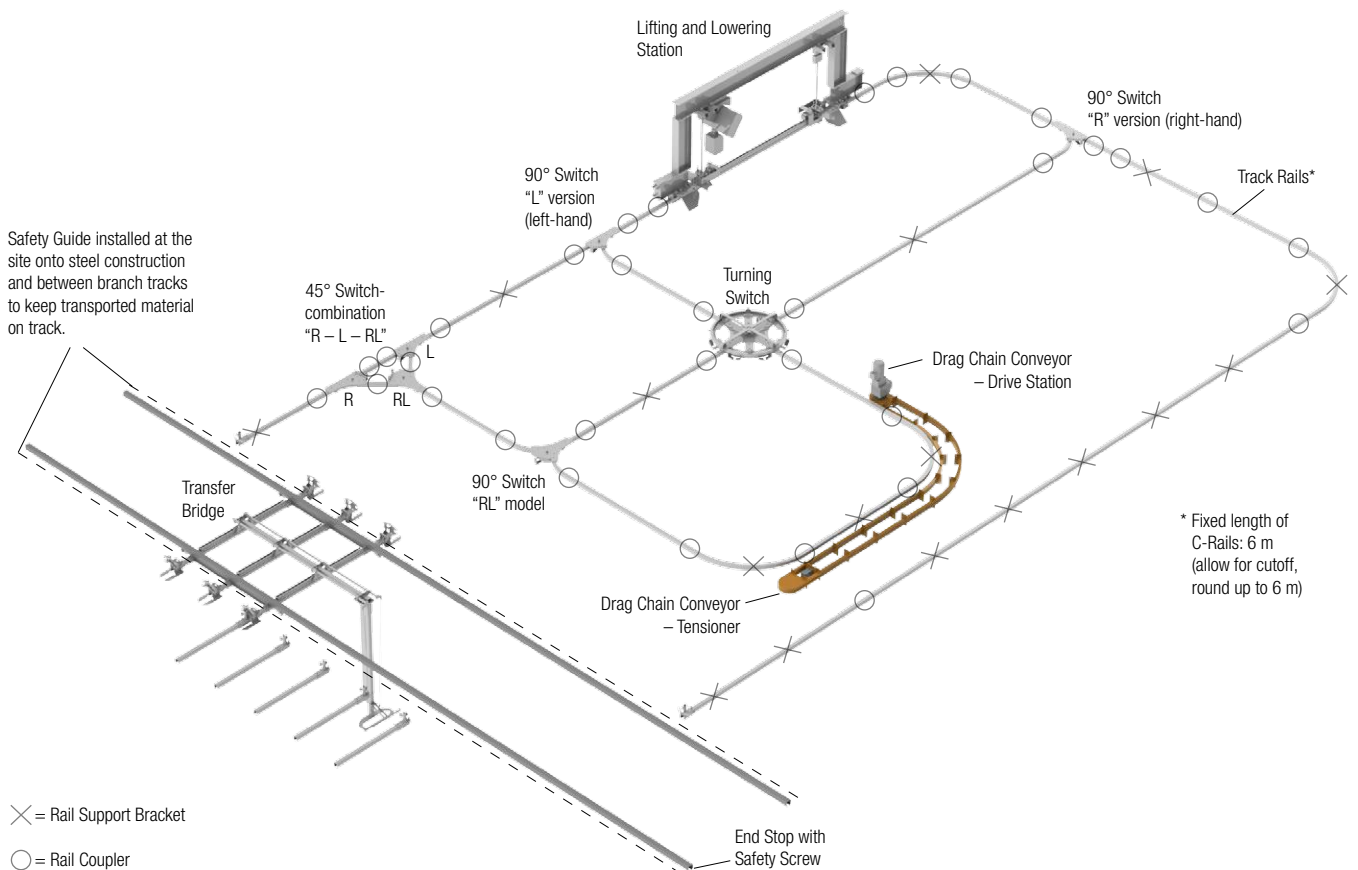

Overhead Monorail Systems Program 1400

Standard Components



Switch



Turning Switch



Switch System

**Easy planning and high reliability
by using standard components**

Rail Program

1450 (40 x 40 mm),
1460 (50 x 50 mm),
1470 (63 x 63 mm),
1480 (80 x 80 mm)

Curves

90°, 45°

Switches

- Manual
- Pneumatic (by request)

Turning Switches

- Sorts material flow at crossover points
- Available in manual or pneumatic versions

Transfer Bridges

Transports material cross-line direction

Suspension Trolleys

- With or without traverses
- With or without pendulum bolts
- With or without guiding rollers
- With or without counterpressure rollers

Lifting Gear

Standard design – special designs according
to customer request available

Lifting and Lowering Stations

To bridge different heights using synchronized chain
hoists (e.g. for immersion baths or hanging up/taking
down material)

Motor-driven rail sections

To overcome inclines, for travel
through a drying furnace, etc.

Accessories

- Suspension for fastening on ceilings
or structural steel work
- Stops / Latches for securing loads
- Swivel guides



Transfer Bridge



Lifting and Lowering Station



Swivel Guide

Overhead Monorail Systems Program 1400

C-Rails

Material: Steel

Finish: Galvanized or Bright Steel

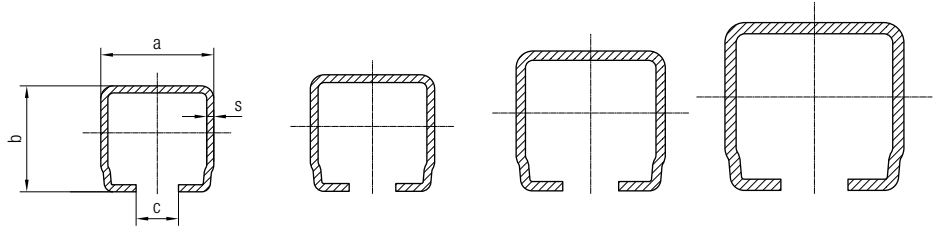

Technical Data		Part No.			
Rail Type		40 x 40	50 x 50	63 x 63	80 x 80
Finish	Galvanized	145005	146005	147005	148005
	Bright steel	145000	146000	147000	148000
Dimensions (mm)	a	40	50	63	80
	b	40	50	63	80
	c	14	16	16	18
	s	2.5	3.5	4	5
Static Values	J_x (cm ⁴)	7	17.8	44.2	117.6
	W_x (cm ³)	3.16	6.4	12.9	27.4
	Weight (kg/m)	2.55	4.1	6.53	10.52
Max. Load (kg/m)		200	320	500	800

Note: The required support distance depends on the application – see page 47f.

Curves

Program 1400

Selecting Curves

To optimize the travel of the Suspension Trolleys around curves, the axis-center distance "L" must not be bigger than the curve radius "R".

If the axis-center distance is considerably larger than the curve radius, the front Suspension Trolley is almost perpendicular to the slide direction. This can cause the Traverse Trolley to jam.

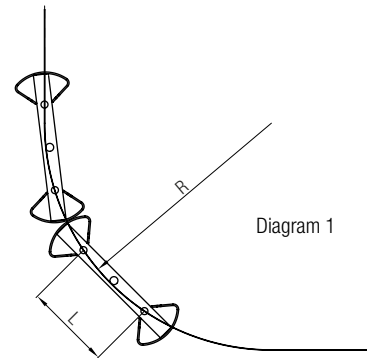

Note:

The slide direction of a Trolley should never deviate more than 45° (displacement angle "a") from the traverse!

Corrective Action:

Choose a bigger curve (as shown in Diagram 1), or ease the curve with diagonal travel.

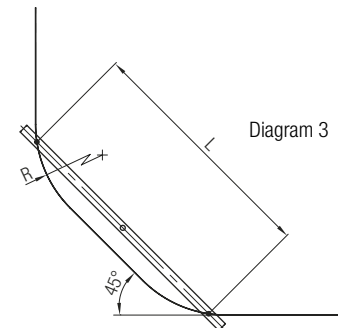
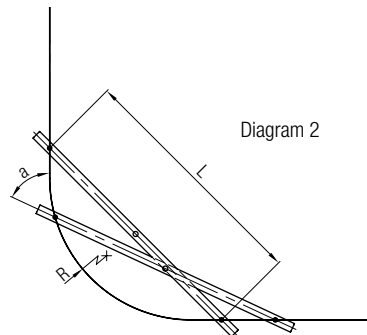

Curves 90°

Material: Steel
Finish: Galvanized

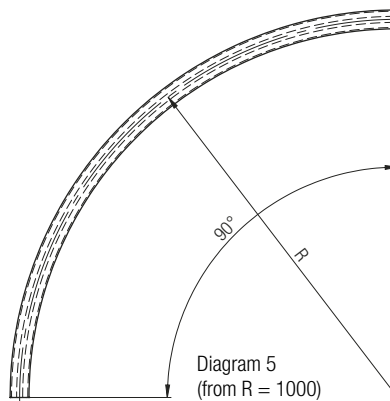
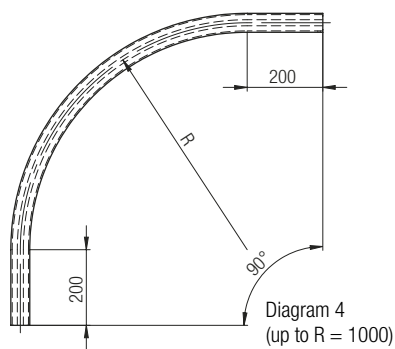

Diagram	Radius (mm)	Part No.			
		40 x 40	50 x 50	63 x 63	80 x 80
4	400	145405-00400	146405-00400	—	—
	600	145405-00600	146405-00600	147405-00600	148405-00600
	800	145405-00800	146405-00800	147405-00800	148405-00800
5	1000	145405-01000	146405-01000	147405-01000	148405-01000
	1200	145405-01200	146405-01200	147405-01200	148405-01200
	1600	145405-01600	146405-01600	147405-01600	148405-01600

Note: Please observe suspension trolleys' specifications regarding minimum radiuses. Other curves available by request, e.g. for curves with radiuses 1400 mm and 2000 mm.

Curves

Program 1400

Curves 45°

Material: Steel
Finish: Galvanized

Left-hand version (L)
(straight section left side)

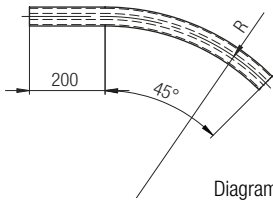
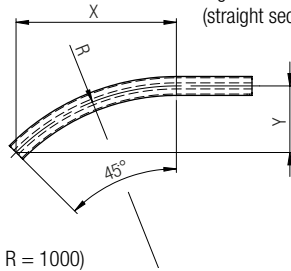

Diagram 6 (up to R = 1000)

Right-hand version (R)
(straight section right side)



Curve without straight section

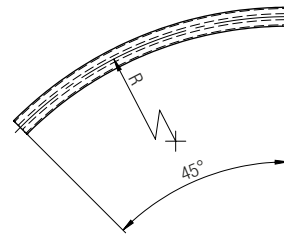

Diagram 7 (from R = 1000)



Diagram	Radius (mm)	Part No.				
		40 x 40	50 x 50	63 x 63	80 x 80	
6	R	400	145415-00400R	146415-00400R	147415-00400R	148415-00400R
		600	145415-00600R	146415-00600R	147415-00600R	148415-00600R
		800	145415-00800R	146415-00800R	147415-00800R	148415-00800R
	L	400	145415-00400L	146415-00400L	147415-00400L	148415-00400L
		600	145415-00600L	146415-00600L	147415-00600L	148415-00600L
		800	145415-00800L	146415-00800L	147415-00800L	148415-00800L
7	1000	145415-01000	146415-01000	147415-01000	148415-01000	
	1200	145415-01200	146415-01200	147415-01200	148415-01200	
	1600	145415-01600	146415-01600	147415-01600	148415-01600	
Project Planning Dimensions						
$x = R \cdot 0.707$						
$y = R \cdot 0.293$						

Note: Other curves available by request.

Rail Support Brackets and Rail Couplers Program 1400

Rail Support Brackets – Basic Design

Material: Steel
Finish: Bright Steel

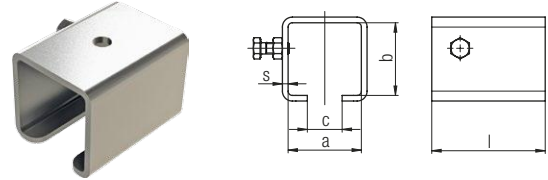

Technical Data		Part No.			
Rail Type		40 x 40	50 x 50	63 x 63	80 x 80
		024120	025120	025620	026120
Dimensions (mm)	a	41.3	51.7	65.5	83
	b	41	51.2	64.2	83
	c	18.4	24.6	26	34
	l	50	80	100	120
	s	4	4	5	6
Max. Load (kg)		250	400	630	820
Weight (kg)		0.22	0.50	0.94	1.75

Rail Couplers – Basic Design

Material: Steel
Finish: Galvanized or Bright Steel

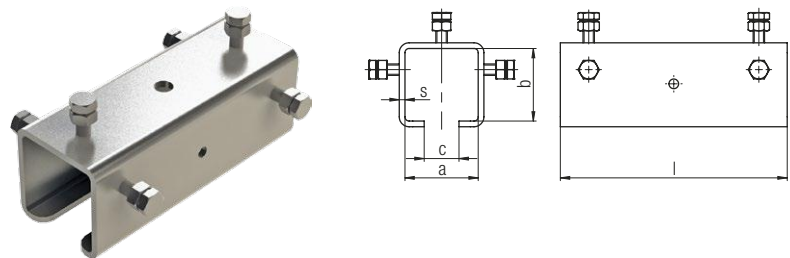

Technical Data		Part No.			
Rail Type		40 x 40	50 x 50	63 x 63	80 x 80
Finish	Galvanized	145605	146605	147605	148605
	Bright steel	024140	025140	025640	026140
Dimensions (mm)	a	41.3	51.7	65.5	83
	b	41	51.2	64.2	83
	c	18.4	24.6	26	34
	l	125	160	200	250
	s	4	4	5	6
Max. Load (kg)		250	400	630	820
Weight (kg)		0.6	1	1.9	3.6

Rail Support Brackets and Rail Couplers Program 1400

Rail Support Brackets – with Crosshead

Material: Steel
Finish: Galvanized

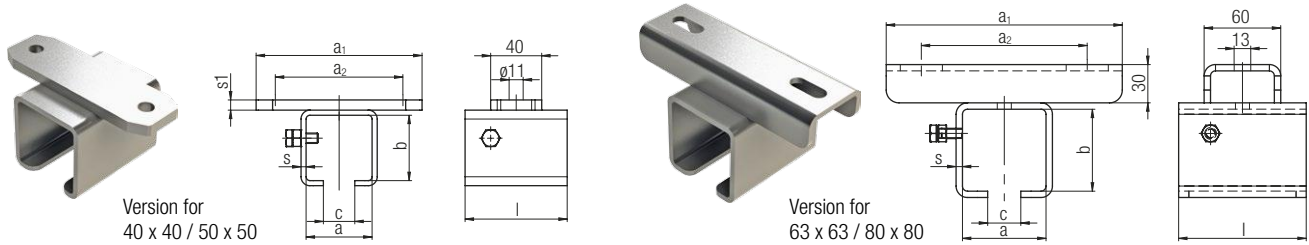

Technical Data		Part No.			
Rail Type		40 x 40	50 x 50	63 x 63	80 x 80
		145511	146511	147511	148511
Dimensions (mm)	a	41.3	51.7	65.5	83
	b	41	51.2	64.2	83
	a ₁	110	130	185	185
	a ₂	80	100	130	130
	c	18.4	24.6	26	34
	l	50	80	100	120
	s	4	4	5	6
	s ₁	6	8	–	–
Max. Load (kg)		250	400	630	820
Weight (kg)		0.36	0.80	1.65	2.40

Rail Couplers – with Crosshead

Material: Steel
Finish: Galvanized

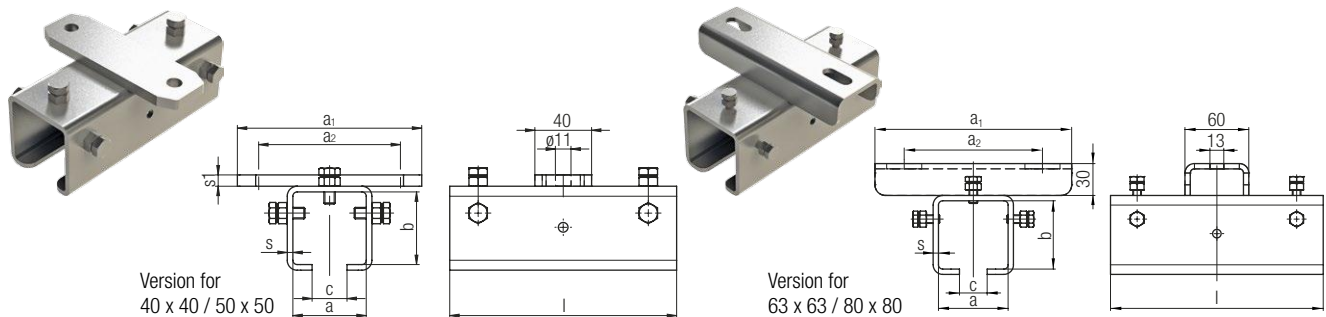

Technical Data		Part No.			
Rail Type		40 x 40	50 x 50	63 x 63	80 x 80
		145611	146611	147611	148611
Dimensions (mm)	a	41.3	51.7	65.5	83
	b	41	51.2	64.2	83
	a ₁	110	130	185	185
	a ₂	80	100	130 ±10	130 ±10
	c	18.4	24.6	26	34
	l	125	160	200	250
	s	4	4	5	6
	s ₁	6	8	–	–
Max. Load (kg)		250	400	630	820
Weight (kg)		0.66	1.30	2.65	4.15

Rail Support Brackets and Rail Couplers Program 1400

Rail Support Brackets – with Screw

Material: Steel
Finish: Galvanized

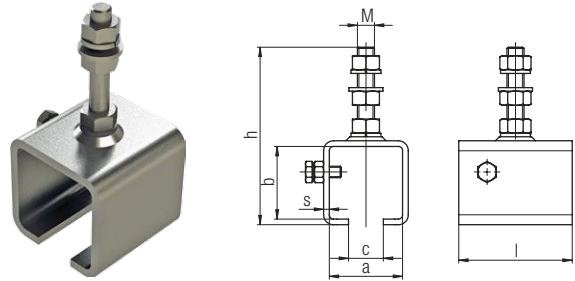

Technical Data		Part No.			
Rail Type		40 x 40	50 x 50	63 x 63	80 x 80
		145525-...	146525	147525	148525
Dimensions (mm)	a	40.5	51.7	64.7	81.7
	b	40.5	51.7	64.7	81.7
	c	17	25	25	31
	h	110	125	140	170
	l	50	80	100	120
	M	M8 or M12	M12	M12	M16
	s	4	4	5	6
Max. Load (kg)		200	320	400	500
Weight (kg)		0.32	0.52	0.97	1.80

Note: Rail Support Brackets and Rail Couplers for C-Rails 40 x 40 are available with thread M8 or M12.
Example Order: required **M12** – Part No.: 145525-12

Rail Couplers – with Screw

Material: Steel
Finish: Galvanized

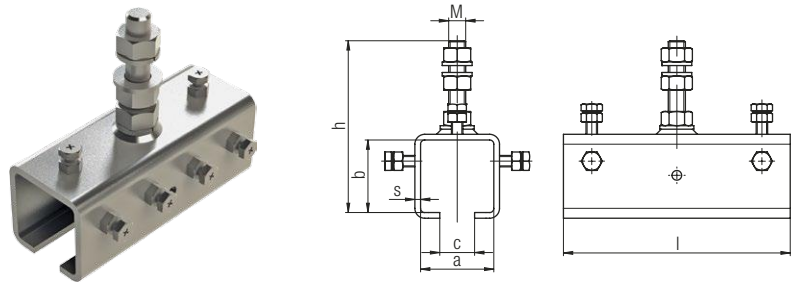

Technical Data		Part No.			
Rail Type		40 x 40	50 x 50	63 x 63	80 x 80
		145625-...	146625	147625	148625
Dimensions (mm)	a	40.5	51.7	64.7	81.7
	b	40.5	51.7	64.7	81.7
	c	17	25	25	31
	h	110	125	140	170
	l	125	160	200	250
	M	M8 or M12	M12	M12	M16
	s	4	4	5	6
Max. Load (kg)		200	320	400	500
Weight (kg)		0.61	1.02	1.93	3.70

Note: Rail Support Brackets and Rail Couplers for C-Rails 40 x 40 are available with thread M8 or M12.
Example Order: required **M12** – Part No. 145625-12

Rail Support Brackets and Rail Couplers Program 1400

Rail Support Brackets – with Support Arm

Material: Steel
Finish: Galvanized

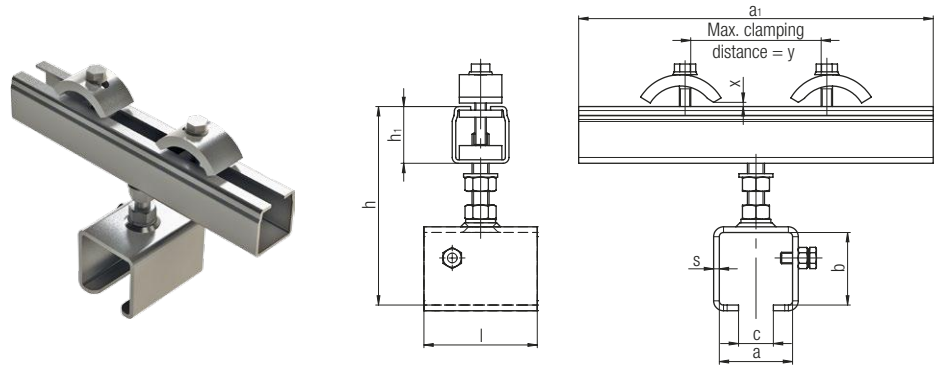

Technical Data		Part No.			
Rail Type		40 x 40	50 x 50	63 x 63	80 x 80
Dimensions (mm)		145541	146541	147541	148541
	a	41.3	51.7	65.5	86
	b	41	51.2	64.2	82
	a ₁	250	250	315	315
	c	17	25	25	31
	h	115-135	125-145	160-180	190-203
	h ₁	40	40	63	63
	l	50	80	100	120
	s	4	4	5	6
	x	clamping thickness 6-20		clamping thickness 6-11	clamping thickness 6-14
y	clamping distance 42-130		clamping distance 42-220		
Max. Load (kg)		200	320	400	500
Weight (kg)		1.3	1.7	3.2	4.4

Rail Couplers – with Support Arm

Material: Steel
Finish: Galvanized

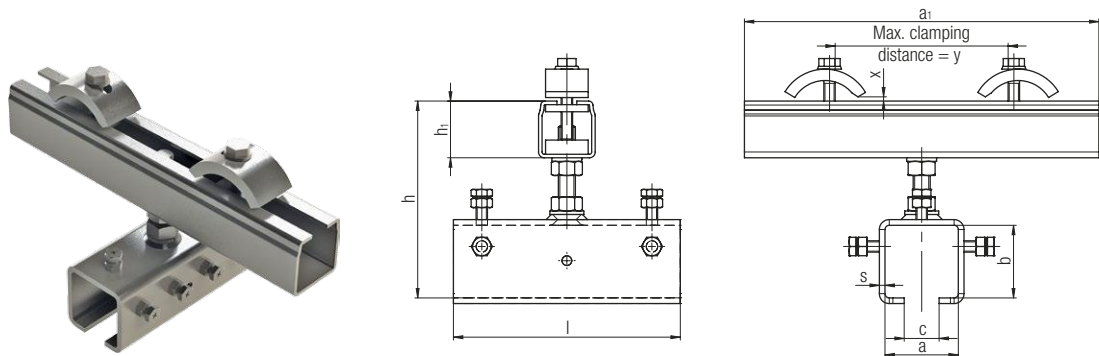

Technical Data		Part No.			
Rail Type		40 x 40	50 x 50	63 x 63	80 x 80
Dimensions (mm)		145641	146641	147641	148641
	a	41.3	51.7	65.5	86
	b	41	51.2	64.2	82
	a ₁	250	250	315	315
	c	17	25	25	31
	h	115-135	125-145	160-180	190-203
	h ₁	40	40	63	63
	l	125	160	200	250
	s	4	4	5	6
	x	clamping thickness 6-20		clamping thickness 6-11	clamping thickness 6-14
y	clamping distance 42-130		clamping distance 42-220		
Max. Load (kg)		200	320	400	500
Weight (kg)		1.6	2.1	4.2	6.3

Rail Support Brackets and Rail Couplers Program 1400

Rail Support Brackets – Two-piece

Material: Steel
Finish: Galvanized

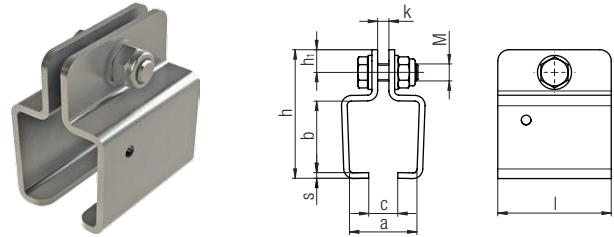

Technical Data		Part No.			
Rail Type		40 x 40	50 x 50	63 x 63	80 x 80
		024129	025129	025629	026129
Dimensions (mm)	a	40	50	63	80
	b	40	50	63	80
	c	17	25	25	31
	h	81	91	114	143
	h ₁	16	16	20	25
	k	6	8	10	12
	l	50	80	100	120
	M	M10	M12	M16	M20
	s	4	4	5	6
Max. Load (kg)		250	400	630	820
Weight (kg)		0.7	1.3	2.6	4.1

Rail Couplers – Two-piece

Material: Steel
Finish: Galvanized

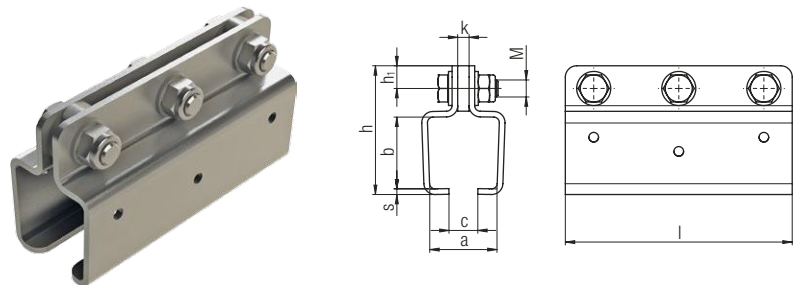

Technical Data		Part No.			
Rail Type		40 x 40	50 x 50	63 x 63	80 x 80
		024149	025149	025649	026149
Dimensions (mm)	a	40	50	63	80
	b	40	50	63	80
	c	17	25	25	31
	h	81	91	114	143
	h ₁	16	16	20	25
	k	6	8	10	12
	l	120	160	200	250
	M	M10	M12	M16	M20
	s	4	4	5	6
Max. Load (kg)		250	400	630	820
Weight (kg)		0.7	1.3	2.6	4.1

Combined Rail Support Brackets and Rail Couplers Program 1400

Parts for Mounting on Support Arms

Material: Steel
Finish: Galvanized

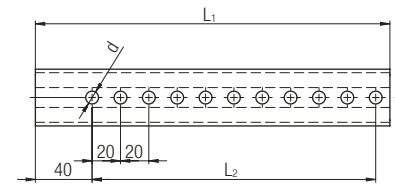
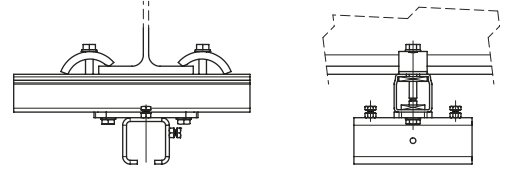

Support Arm
Material: Steel
Finish: Galvanized

Dimensions (mm)		Part No.			
L ₁	L ₂	40 x 40	50 x 50	63 x 63	80 x 80
250	200	020186-0250	020278-0250	020274-0250	
315	260	020186-0315	020278-0315	020274-0315	
400	340	020186-0400	020278-0400	020274-0400	
500	340	020186-0500	020278-0500	020274-0500	
Bore Diameter "d"		9	11	11	

Rail Support Brackets and Rail Couplers

Material: Steel
Finish: Galvanized

Version	Part No.			
Rail Type	40 x 40	50 x 50	63 x 63	80 x 80
Rail Support Bracket	145511	146511	147511	148511
Rail Coupler	145611	146611	147611	148611

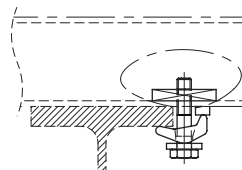
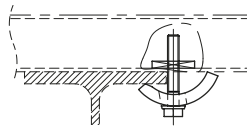

Girder Clip; single

Material: Steel
Finish: Galvanized

For dimensions, see next page

Rail Type	Part No.			
	40 x 40	50 x 50	63 x 63	80 x 80
	040127-08	040127-10	040127-10	040127-12
Screw Type	M8 x 50	M10 x 50	M10 x 50	M12 x 60

Screw with Square Nut for C-Rails

Material: Steel
Finish: Galvanized

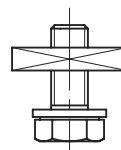

Rail Type	Part No.			
	40 x 40	50 x 50	63 x 63	80 x 80
	040125-08x15	040125-10x12	040125-10x12	040125-10x12
Screw Type	M8 x 25	M10 x 25	M10 x 25	M12 x 25
Max. clamping distance	14.5	12	12	12

Note: When using other components from Conductix-Wampfler check connection dimensions!

Girder Clips Program 1400

Girder Clips M8

For Rail types 40 x 40 and 50 x 50

	Part No.						
	040127-08						
Clamping thickness "s"	4	6	8	10	12	16	20
Installation height "h"	31	32	33	34	35	37	40

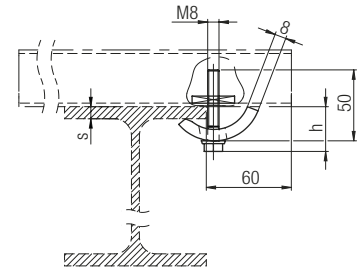

Girder Clips M10 and M12

For Rail types 63 x 63 and 80 x 80

Technical Data		Part No.				
Thread Diameter "M"		M10		M12		
		040127-10		040127-12		
Dimensions (mm)	l	50		60		
	a	8		10		
	s	s ₁	s ₂	s ₁	s ₂	
		6-11	—	6-14	—	
		11-16	5	14-22	8	
	h	35-41		39-47		
		41-46		47-55		
46-51		55-63				
Weight (kg)		0.170		0.240		

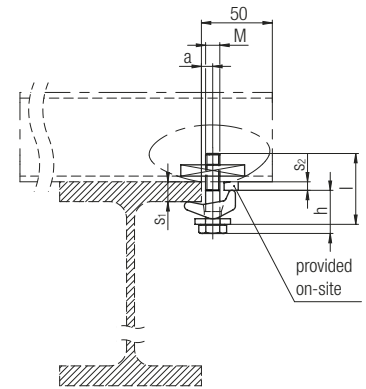

End Stops Program 1400

End Stop



Internal version for C-Rails 40 x 40 to 80 x 80

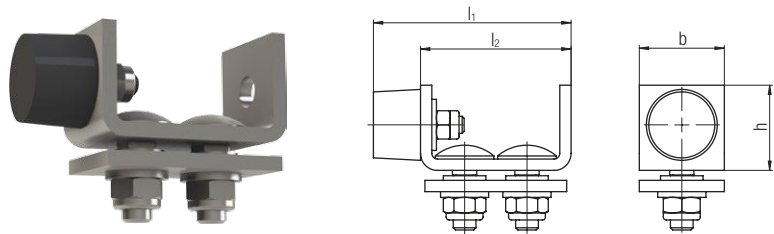

Technical Data		Part No.			
Rail Type		40 x 40	50 x 50	63 x 63	80 x 80
		145500	146500	147500	148500
Dimensions (mm)	b	30	30	45	60
	h	30	30	50	60
	l ₁	69	69	100	120
	l ₂	53	53	80	100
Weight (kg)		0.28	0.31	0.58	1.07

Assembly Instructions: End Stops must be secured by a safety screw crosswise to the rail. Safety Screw is included in the scope of delivery.

Project planning note: To avoid shearing forces in the pendulum bolts when Traverse Trolleys/Support Trolleys rapidly drive in end position, we recommend using an additional exterior End Stop.
Application-specific End Stops available by request.

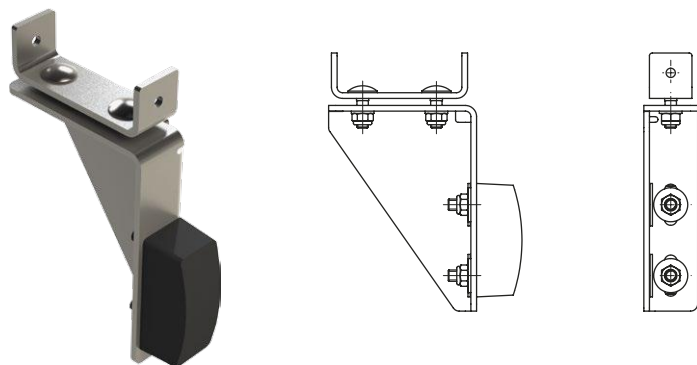

Suspensions for Monorail Systems Program 1400

Suspensions

In addition to the various mounting options with Rail Support Brackets directly to the ceiling, suspensions often need to be used, e.g. on saw-tooth roofs, or under structural steel work.

Single-point Suspensions

Determining the length of threaded rods (mm):

Diagram 1 and 2:
(for vertical
suspension only)

$$L_1 = L_0 - 320$$

Diagram 2 and 3:
(for inclined
suspension only)

$$L_2 = \frac{L_0}{\cos \alpha} - 450$$

Diagram 4: L_3 and L_4 have to be determined graphically and calculative, depending on the corresponding incline of the ceiling.

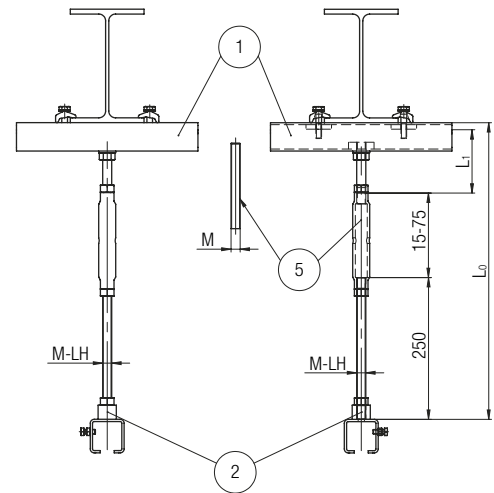

Diagram 1

M-LH = left-handed thread

V-shaped Suspensions

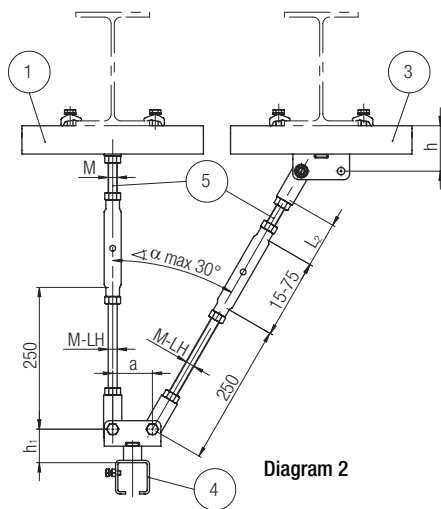

Diagram 2

M-LH = left-handed thread

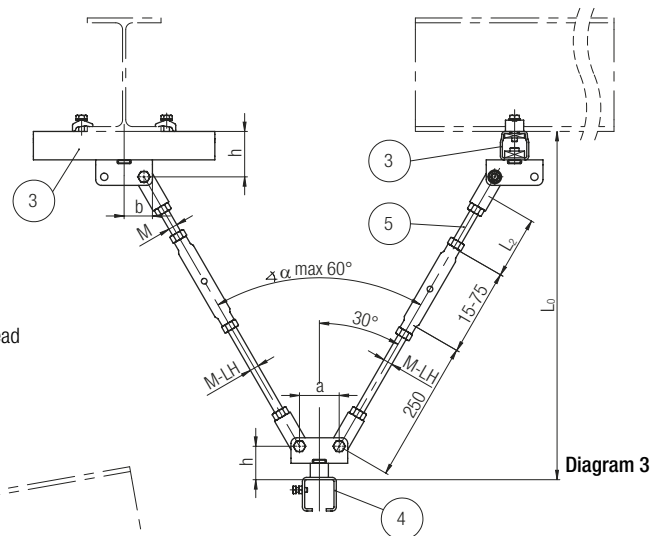

Diagram 3

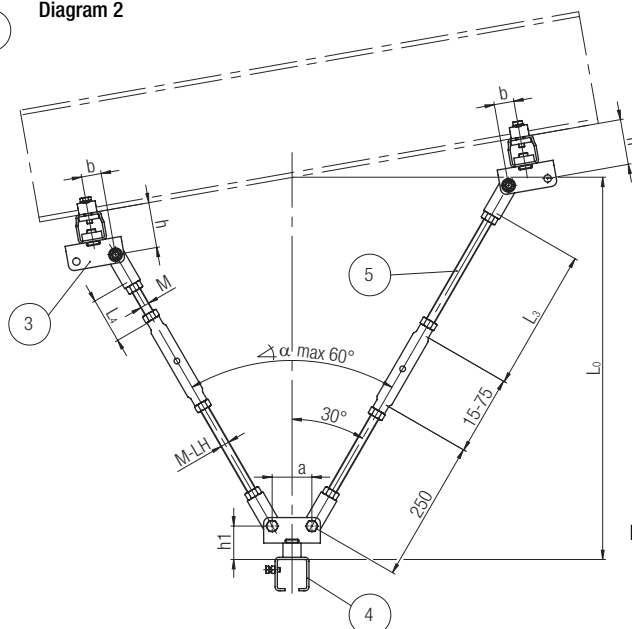

Diagram 4

Suspensions for Monorail Systems Program 1400

Suspensions

The bottom parts (Positions 2 or 4) can be rotated to adjust the direction of the rails and to enable the suspension of curves.

Example Order: Required suspension according to Diagram 2, $L_0=1.5$ m for C-Rail 145005, angle $\alpha = 20^\circ$, Rail Support Bracket version.

Part No.:

- Pos. ① Suspension – Upper part 145211
- Pos. ② Suspension – Bottom part 145221-A
- Pos. ③ Suspension – Upper part 145212
- Pos. ④ Suspension – Bottom part 145222-A
- Pos. ⑤ Threaded rod M12

Technical Data			Part No.			
Rail Type			40 x 40	50 x 50	63 x 63	80 x 80
	Description	Position No.				
Single-point suspension (vertical)	Upper part	①	145211	146211	147211	148211
	Bottom part*	②	145221-	146221-	147221-	148221-
	Threaded rod 3 m	⑤	145210-3	146210-3	147210-3	147210-3
V-shaped suspension (inclined)	Upper part	③	145212	146212	147212	148212
	Bottom part*	④	145222-	146222-	147222-	148222-
	Threaded rod 3 m	⑤	DIN 975-M12	DIN 975-M16	DIN 975-M20	DIN 975-M20
Dimensions (mm)	h		90	80	110	110
	h_1		60	60	85	85
	M		M12	M16	M20	M20
	a		60	70	100	100
	b		30	35	50	50

Standard delivery length of threaded rods is 3 m. Cut to desired length before installation.

* Bottom parts ② and ④ are available in the following versions: a) Rail Support Bracket = Version A, b) Rail Coupler = Version B

Note: It is vital to state Version A or B when ordering! These bottom parts are delivered with turnbuckles. The valid support distance depends on the application (to determine the valid support distance see page 47).

Rail Suspension on Concrete Ceilings

When mounted directly on the ceiling, the possibility to adjust the level of the rail track is limited (stiffener plates necessary). Use of Rail Couplers is restricted.

Using holding plates allows for versatile mounting and alignment options.

Note:

When mounting the Rail Suspensions for C-Rails 1450 and 1460 directly below the ceiling, Suspensions have to be shimmed to allow for clamping of the Rail Suspension on the back of the rail. We therefore recommend using our Suspension Clamp (Part-No. 145241).

We recommend verification of the load capacity of the ceilings or structural steel work by a structural engineer.

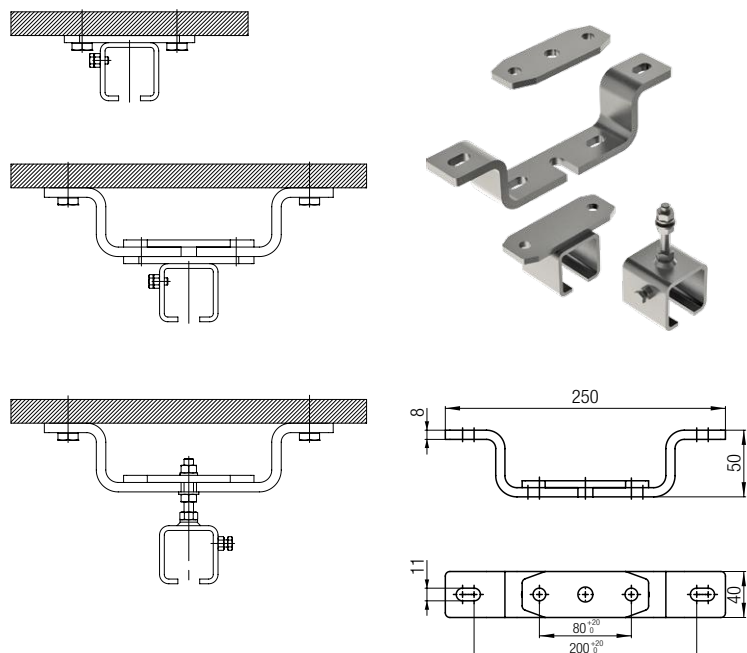

Switches

Program 1400

Switches – General Information

Flap Switch

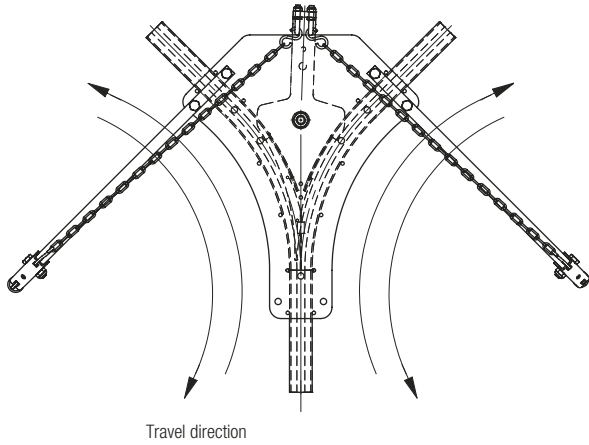

Flap switches are operated manually by a system of levers. Once positioned, the switch is locked in place.

Trolleys can pass these switches in both travel directions.

Point Switch

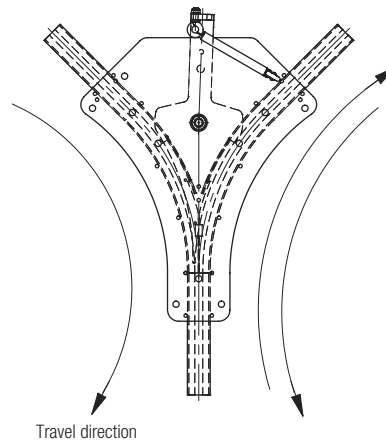

Point switches are operated by trolleys passing through. After actuation, the switch is automatically set back to default position by a spring. Trolleys can pass these switches in one travel direction only.

Note: Point switches can be turned into flap switches retroactively. Detailed information available by request.

Turning Switches

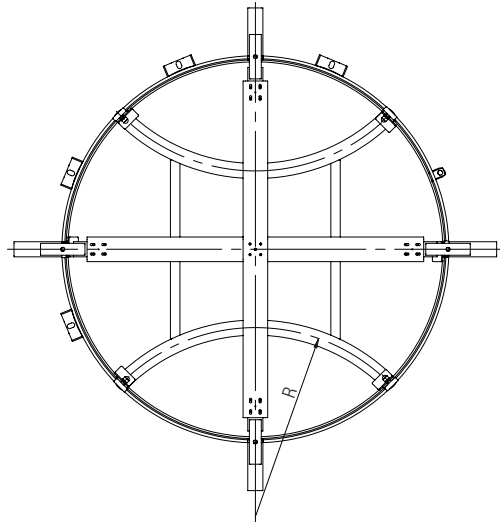

Turning switches are used to sort material flow at crossover points. Manual or pneumatic versions available.

Trolleys can pass these switches in both travel directions.

Switches

Program 1400

Chain-hoists/Handles for Flap Switches – General Information

Flap switches are operated manually by a chain-hoist or handle. Once positioned, the switch is locked in place. Trolleys can pass in both travel directions.

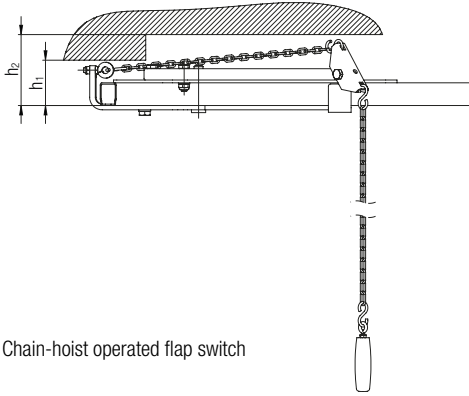

Chain-hoist operated flap switch

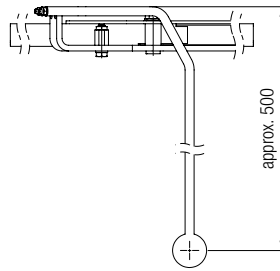

Handle-operated flap switch

Note: Pneumatic operating devices available by request.

Switches Program 1400

Switches – Galvanized

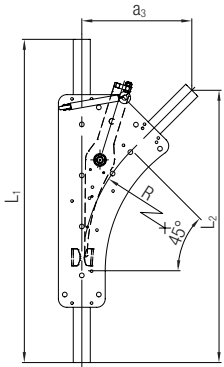

Point switch 45°
Right-hand version

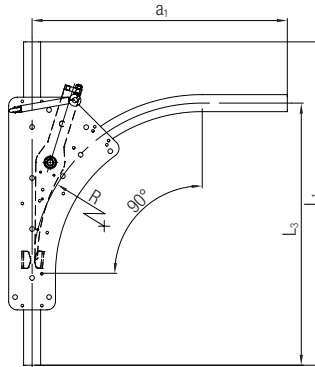

Point switch 90°
Right-hand version

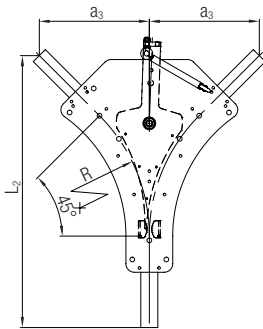

Point switch 45°
Right and left-hand version

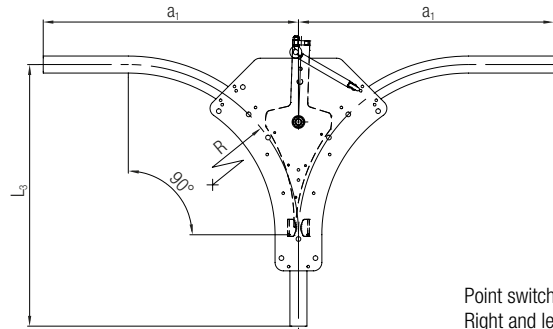

Point switch 90°
Right and left-hand version

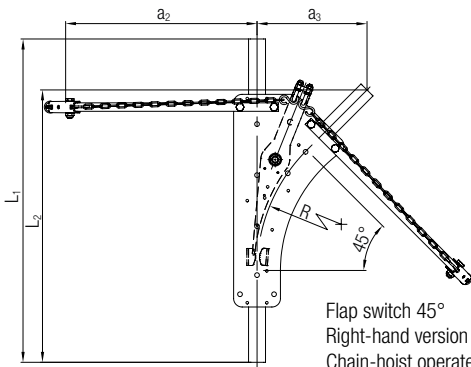

Flap switch 45°
Right-hand version
Chain-hoist operated

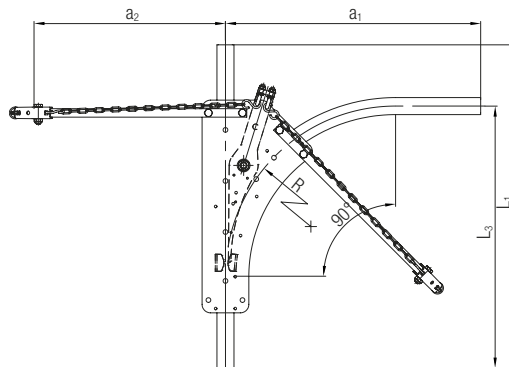

Flap switch 90°
Right-hand version
Chain-hoist operated

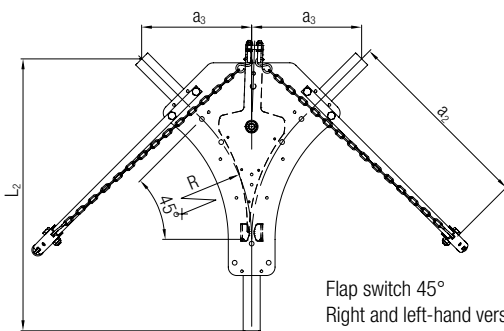

Flap switch 45°
Right and left-hand version
Chain-hoist operated

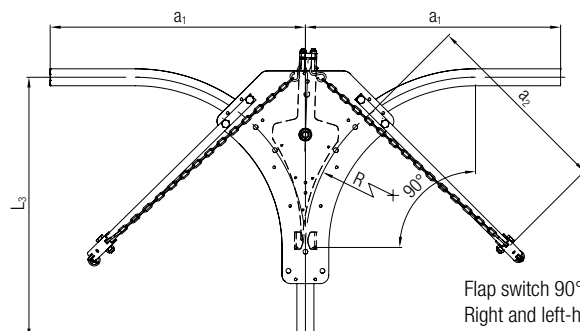

Flap switch 90°
Right and left-hand version
Chain-hoist operated

If the transported material protrudes further than dimension a_2 (see next page) to the left or right side of the rail, the chain hoist/handle of the Flap switch must be extended, to avoid collision with the material.

Switches Program 1400

Installation Dimensions

Switches are mounted to the C-Rails with three Rail Couplers. The Rail Couplers are ordered separately.

Installation Dimensions of Switches:

Rail Type		40 x 40	50 x 50	63 x 63	80 x 80
		Dimensions (mm)			
Project Planning Dimensions	a ₁	600	600	800	800
	a ₂	440	440	670	670
	a ₃	259	259	317	317
	L ₁	760	830	1060	1365
	L ₂	640	680	870	920
Installation Dimensions	L ₃	616	656	905	955
	R	400	400	600	600
	h ₁	82	92	112	115
	h ₂	120	140	170	190

Installation Dimensions of Switch combinations:

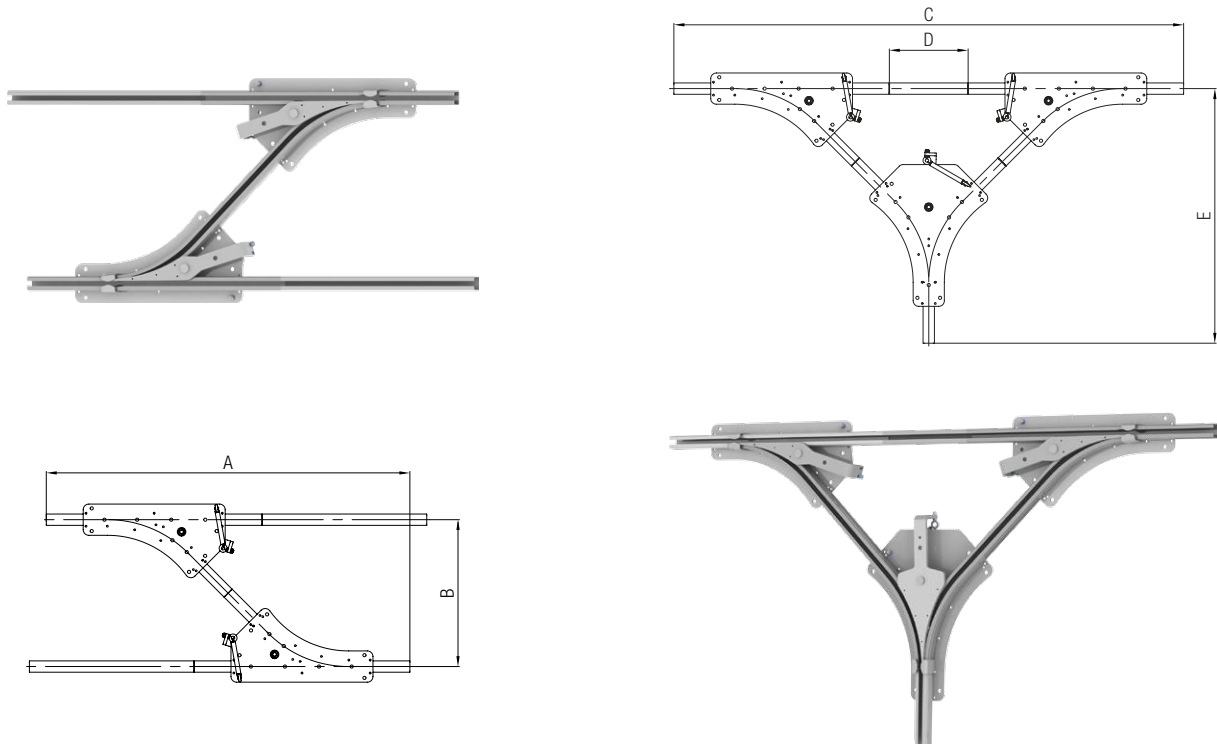

Rail Type		40 x 40	50 x 50	63 x 63	80 x 80
		Dimensions (mm)			
Project Planning Dimensions	A	1280	1360	1742	1840
	B	517	517	634	634
	C	1798	1877	2375	2730
	D	277	217	255	-
	E	898	933	1188	1366

Note: a 45° Switch can be turned into a 90° Switch by using a 45° Curve.

Switches Program 1400

For C-Rails 40 x 40

Switch Type		Part No.
Point Switch 45°	Right-hand	145311-R
	Left-hand	145311-L
	Right-hand / Left-hand	145311-RL
Point Switch 90°	Right-hand	145313-R
	Left-hand	145313-L
	Right-hand / Left-hand	145313-RL



Point Switch 45°
Right-hand – 145311-R



Point Switch 45°
Left-hand – 145311-L



Point Switch 45°
Right-hand / Left-hand – 145311-RL



Point Switch 90°
Right-hand / Left-hand – 145313-RL

Switch Type		Part No. (with Chain-hoist)	Part No. (with Handle)
Flap Switch 45°	Right-hand	145315-R03	145315-R02
	Left-hand	145315-L03	145315-L02
	Right-hand / Left-hand	145315-RL03	145315-RL02
Flap Switch 90°	Right-hand	145317-R03	145317-R02
	Left-hand	145317-L03	145317-L02
	Right-hand / Left-hand	145317-RL03	145317-RL02

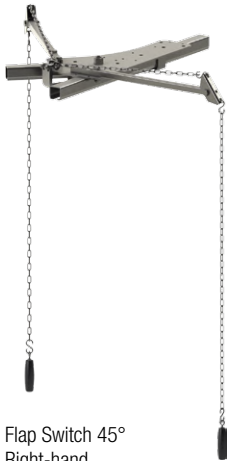

Flap Switch 45°
Right-hand
with chain-hoist
– 145315-R03



Flap Switch 45°
Right-hand / Left-hand
with chain-hoist
– 145315-RL03



Flap Switch 90°
Left-hand
with handle
– 145317-L02

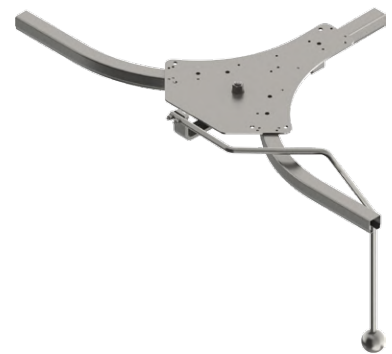

Flap Switch 90°
Right-hand / Left-hand
with handle
– 145317-RL02

Switches Program 1400

For C-Rails 50 x 50

Switch Type		Part No.
Point Switch 45°	Right-hand	146311-R
	Left-hand	146311-L
	Right-hand / Left-hand	146311-RL
Point Switch 90°	Right-hand	146313-R
	Left-hand	146313-L
	Right-hand / Left-hand	146313-RL



Point Switch 45°
Right-hand – 146311-R



Point Switch 45°
Left-hand – 146311-L



Point Switch 45°
Right-hand / Left-hand – 146311-RL



Point Switch 90°
Right-hand / Left-hand – 146313-RL

Switch Type		Part No. (with Chain-hoist)	Part No. (with Handle)
Flap Switch 45°	Right-hand	146315-R03	146315-R02
	Left-hand	146315-L03	146315-L02
	Right-hand / Left-hand	146315-RL03	146315-RL02
Flap Switch 90°	Right-hand	146317-R03	146317-R02
	Left-hand	146317-L03	146317-L02
	Right-hand / Left-hand	146317-RL03	146317-RL02



Flap Switch 45°
Right-hand
with chain-hoist
– 146315-R03



Flap Switch 45°
Right-hand / Left-hand
with chain-hoist
– 146315-RL03



Flap Switch 90°
Left-hand
with handle
– 146317-L02



Flap Switch 90°
Right-hand / Left-hand
with handle
– 146317-RL02

Switches Program 1400

For C-Rails 63 x 63

Switch Type		Part No.
Point Switch 45°	Right-hand	147311-R
	Left-hand	147311-L
	Right-hand / Left-hand	147311-RL
Point Switch 90°	Right-hand	147313-R
	Left-hand	147313-L
	Right-hand / Left-hand	147313-RL



Point Switch 45°
Right-hand – 147311-R



Point Switch 45°
Left-hand – 147311-L



Point Switch 45°
Right-hand / Left-hand – 147311-RL



Point Switch 90°
Right-hand – 147313-R

Switch Type		Part No. (with Chain-hoist)	Part No. (with Handle)
Flap Switch 45°	Right-hand	147315-R03	147315-R02
	Left-hand	147315-L03	147315-L02
	Right-hand / Left-hand	147315-RL03	147315-RL02
Flap Switch 90°	Right-hand	147317-R03	147317-R02
	Left-hand	147317-L03	147317-L02
	Right-hand / Left-hand	147317-RL03	147317-RL02



Flap Switch 45°
Right-hand
with Chain-hoist
– 147315-R03



Flap Switch 45°
Right-hand / Left-hand
with Chain-hoist
– 147315-RL03



Flap Switch 90°
Left-hand
with Handle
– 147317-L02



Flap Switch 90°
Right-hand / Left-hand
with Handle
– 147317-RL02

Switches Program 1400

For C-Rails 80 x 80

Switch Type		Part No.
Point Switch 45°	Right-hand	148311-R
	Left-hand	148311-L
	Right-hand / Left-hand	148311-RL
Point Switch 90°	Right-hand	148313-R
	Left-hand	148313-L
	Right-hand / Left-hand	148313-RL



Point Switch 45°
Right-hand – 148311-R



Point Switch 45°
Left-hand – 148311-L



Point Switch 45°
Right-hand / Left-hand – 148311-RL



Point Switch 90°
Right-hand – 148313-R

Switch Type		Part No. (with Chain-hoist)	Part No. (with Handle)
Flap Switch 45°	Right-hand	148315-R03	148315-R02
	Left-hand	148315-L03	148315-L02
	Right-hand / Left-hand	148315-RL03	148315-RL02
Flap Switch 90°	Right-hand	148317-R03	148317-R02
	Left-hand	148317-L03	148317-L02
	Right-hand / Left-hand	148317-RL03	148317-RL02



Flap Switch 45°
Right-hand
with Chain-hoist
– 148315-R03



Flap Switch 45°
Right-hand / Left-hand
with Chain-hoist
– 148315-RL03



Flap Switch 90°
Left-hand
with Handle
– 148317-L02



Flap Switch 90°
Right-hand / Left-hand
with Handle
– 148317-RL02

Accessories for Point Switches Program 1400

S-Green Wear Pads

Recommended to keep wear and tear on the points to a minimum.



Right-hand Switch or Left-hand Switch

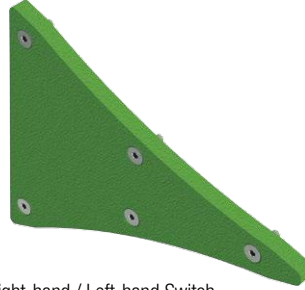

Right-hand / Left-hand Switch

Rail Type	Part No.			
	40 x 40	50 x 50	63 x 63	80 x 80
Right-hand Switch or Left-hand Switch	140312-3		140312-5	
Right-hand / Left-hand Switch	140312-4		140312-6	

Note: Mounting screws are included.

Overhead Monorail Systems Program 1400

Turning Switches

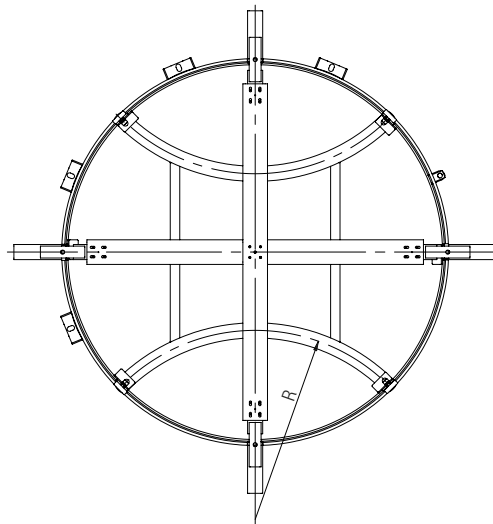
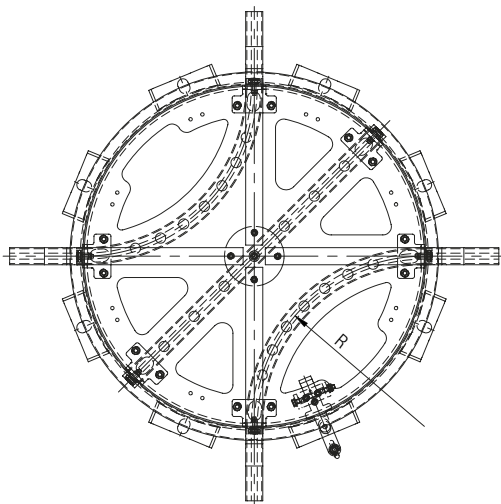
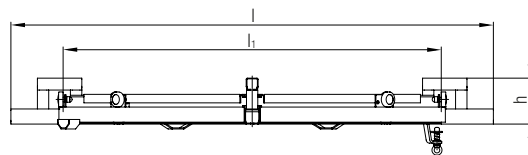
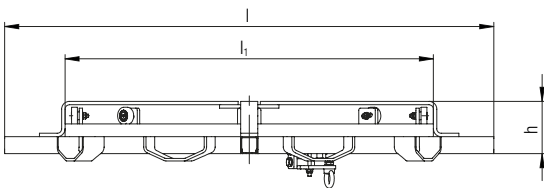
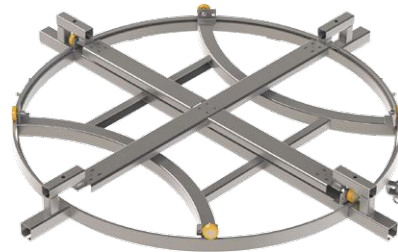

For C-Rails 40 x 40 and 50 x 50

Material: Steel
Finish: Galvanized

For C-Rails 63 x 63 and 80 x 80

Material: Steel
Finish: Painted, standard-silver

Switches are mounted to the C-Rails with four Rail Couplers. The Rail Couplers are ordered separately.

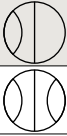
Rail Type		Part No.			
		40 x 40	50 x 50	63 x 63	80 x 80
	With eyelet – one-sided Version	145361-01	146361-01	147361-01	148361-01
	With eyelet – two-sided Version	145362-01	146362-01	147362-01	148362-01
Dimensions (mm)	l	1150	1200	1700	2550
	l ₁	800	800	1230	2030
	R	400	400	600	1000
	h	123	133	226	243

Suspension Trolleys Program 1400

Suspension Trolleys – General Information

Standard Suspension Trolleys have turnable and pendulum bolts (see diagram below).

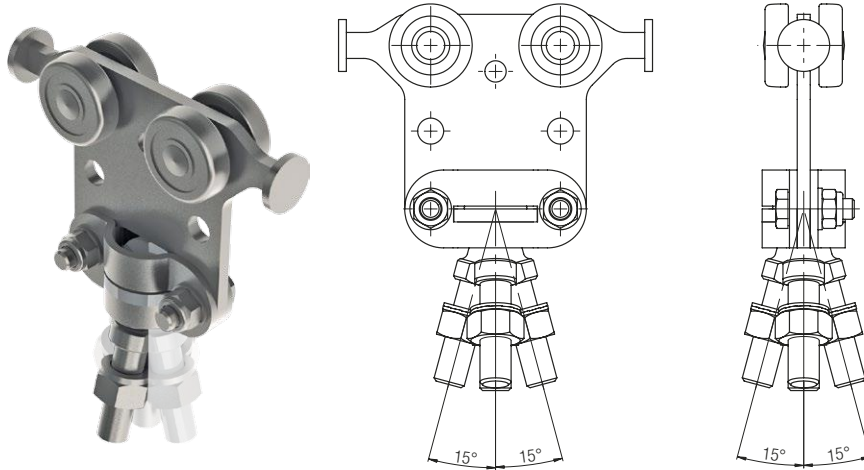

Standard design:

Operating temperature from -20°C to +60 °C

High-temperature version:

Operating temperature from 0°C to +250°C

The stated load carrying capacities refer to a temperature of 20°C.

With temperatures higher than 60°C, load carrying capacity is reduced due to the material used:

- from 60°C to 100°C: approx. 15%
- from 100°C to 200°C: approx. 25%
- from 200°C to 250°C: approx. 40%

Note: Some Suspension Trolleys can be equipped with plastic rollers for quiet running. Please contact us for further details.

Please note: Suspension Trolleys must be maintained in regular intervals according to maintenance instructions.

Suspension Trolleys with two Rollers – Designed to be welded on

Material: Steel

Finish:

Rollers: Galvanized

Body: Bright steel

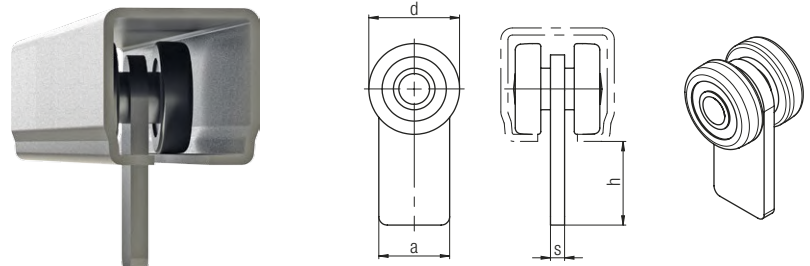

Technical Data		Part No.			
Rail Type		40 x 40	50 x 50	63 x 63	80 x 80
		145093	146093	147093	148093
Dimensions (mm)	a	25	25	40	40
	d	32	40	52	62
	h	29	24	32	26
	s	5	5	8	8
Max. Load (kg)		50	80	100	125
Weight (kg)		0.15	0.25	0.32	0.42

Suspension Trolleys Program 1400

Suspension Trolleys with two Rollers – Standard

Material: Steel
Finish: Galvanized

- Standard design, pendular-mounted
- High-temperature design, pendular-mounted

Suspension Trolleys for C-Rails 40 x 40 are available with threaded ball studs M12 or M16.

Ordering Example:
M12 requested – Part No.: 145010-12B

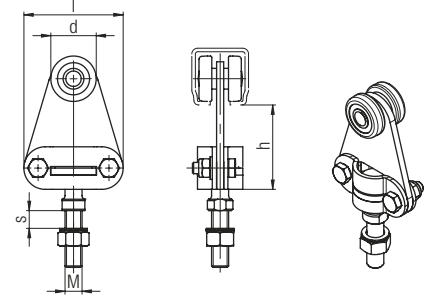

Technical Data		Part No.			
Rail Type		40 x 40	50 x 50	63 x 63	80 x 80
Design	Standard design, pendular-mounted ball stud	145010-..B	146010-B	147010-B	148010-B
	High-temperature design, pendular-mounted ball stud	145110-..B	146110-B	147110-B	148110-B
Dimensions (mm)	d	32	40	52	62
	h	75	70	85	80
	l	70	70	70	70
	M	M12 or M16	M16	M16	M16
	S _{max}	26	26	26	26
Max. Load (kg)		50	80	100	125
Weight (kg)		0.5	0.60	0.75	0.85
Max. Lateral Force (N)		300 (M12) / 700 (M16)	700	600	600

Suspension Trolleys with two Rollers – Ring Nut

Material: Steel
Finish: Galvanized

- Standard design
- High-temperature design

Suspension Trolleys with Ring Nuts are available with pendular-mounted ball studs only.
Suspension Trolleys for C-Rails 40 x 40 are available with threaded ball studs M12 or M16.

Ordering Example:
M12 requested – Part No.: 145011-12B

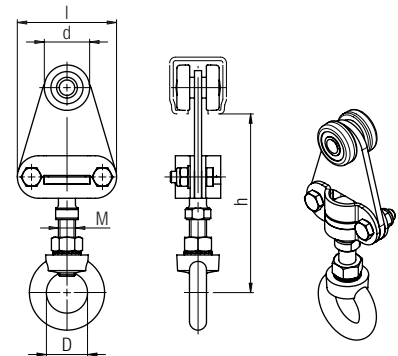

Technical Data		Part No.			
Rail Type		40 x 40	50 x 50	63 x 63	80 x 80
Design	Standard design	145011-..B	146011-B	147011-B	148011-B
	High-temperature design	145111-..B	146111-B	147111-B	148111-B
Dimensions (mm)	d	32	40	52	62
	h	130	125	140	135
	l	70	70	70	70
	M	M12 or M16	M16	M16	M16
	D	30 or 35	35	35	35
Max. Load (kg)		50	80	100	125
Weight (kg)		0.60	0.70	0.85	0.95

Suspension Trolleys Program 1400

Suspension Trolleys with four Rollers – Designed to be welded on

Material: Steel
Finish:
 Rollers: Galvanized
 Body: Bright steel

Note:
 Not suitable for curves with
 a radius smaller than 800 mm.

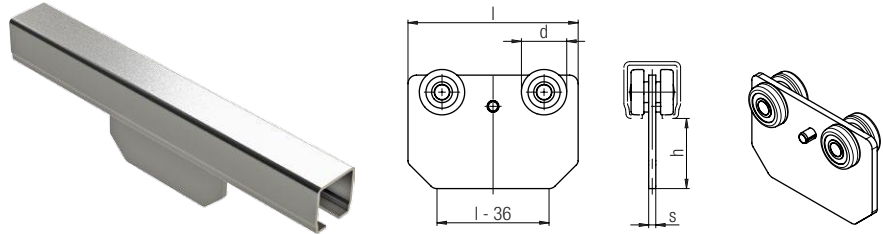

Technical Data		Part No.			
Rail Type		40 x 40	50 x 50	63 x 63	80 x 80
Design	Standard design	145092	146092	147092	148092
	High-temperature design	145192	146192	147192	148192
Dimensions (mm)	d	32	40	52	62
	h	50	45	51	45
	l	120	120	160	160
	s	5	5	8	8
Max. Load (kg)		100	160	200	250
Weight (kg)		0.45	0.55	0.7	0.9

Suspension Trolleys with four Rollers – Standard

Material: Steel
Finish: Galvanized

For curves with radiuses from 400 mm.

- Standard design, pendular-mounted
- High-temperature design, pendular-mounted

Suspension Trolleys for C-Rails 40 x 40 are available with threaded ball studs M12 or M16.

Ordering Example:
M12 requested – Part No.: 145020-12B

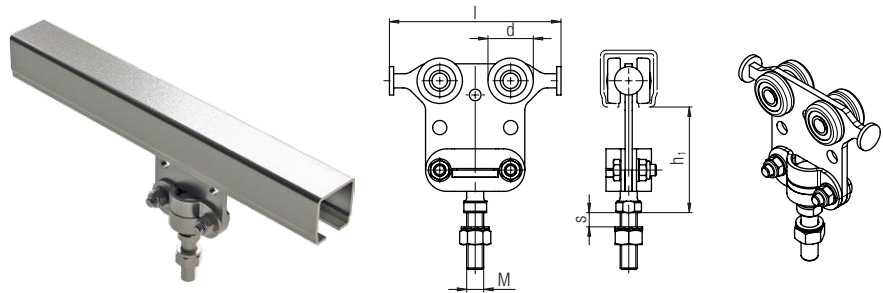

Technical Data		Part No.			
Rail Type		40 x 40	50 x 50	63 x 63	80 x 80
Design	Standard design, pendular-mounted ball stud	145020-..B	146020-B	147020-B	148020-B
	High-temperature design, pendular-mounted ball stud	145120-..B	146120-B	147120-B	148120-B
Dimensions (mm)	d	32	40	52	62
	h ₁	75	70	85	80
	l	120	120	160	160
	M	M12 or M16	M16	M16	M16
	S _{max}	26	26	26	26
Max. Load (kg)		100	160	200	250
Weight (kg)		0.75	0.85	1.00	1.20
Max. Lateral Force (N)		300 (M12) / 700 (M16)	700	600	600

Suspension Trolleys Program 1400

Suspension Trolleys with four Rollers – Ring Nut

Material: Steel
Finish: Galvanized

- Standard design
- High-temperature design

Suspension Trolleys with Ring Nuts are available with pendular-mounted ball studs only.
 Suspension Trolleys for C-Rails 40 x 40 are available with threaded ball studs M12 or M16.

Ordering Example:
 M12 requested – Part No.: 145021-12B

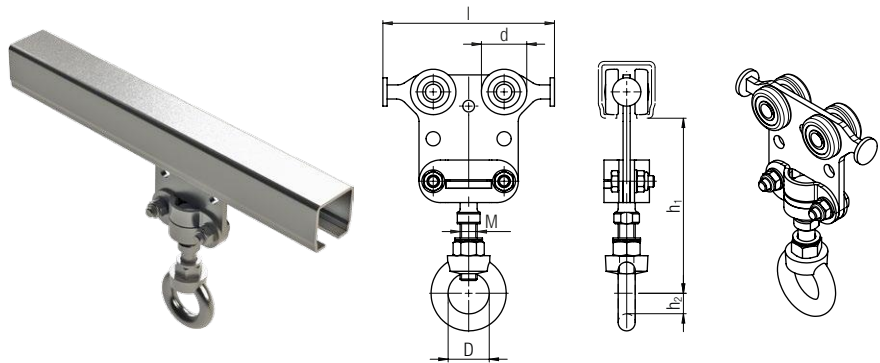

Technical Data		Part No.			
Rail Type		40 x 40	50 x 50	63 x 63	80 x 80
Design	Standard design	145021-..B	146021-B	147021-B	148021-B
	High-temperature design	145121-..B	146121-B	147121-B	148121-B
Dimensions (mm)	d	32	40	52	62
	h ₁	130	125	140	135
	h ₂	32	32	32	32
	l	120	120	160	160
	M	M12 or M16	M16	M16	M16
	D	30 or 35	35	35	35
Max. Load (kg)		100	160	200	250
Weight (kg)		0.85	0.95	1.10	1.30

Suspension Trolleys with four Rollers – for increased Loads

Material: Steel
Finish: Galvanized

- Standard design, pendular-mounted
- High-temperature design, pendular-mounted

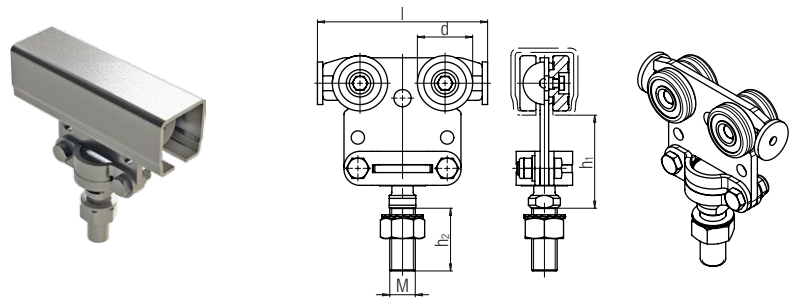

Technical Data		Part No.			
Rail Type		40 x 40	50 x 50	63 x 63	80 x 80
Design	Standard design, pendular-mounted ball stud	–	–	147027	148027
	High-temperature design, pendular-mounted ball stud	–	–	147067	148067
Dimensions (mm)	d	–	–	52	62
	h ₁	–	–	86	80
	h ₂	–	–	59	59
	l	–	–	160	160
	M	–	–	M24	M24
Max. Load (kg)		–	–	400	500
Weight (kg)		–	–	–	–
Max. Lateral Force (N)		–	–	1800	1800

Suspension Trolleys Program 1400

Suspension Trolleys for Load Hooks – with Cross Bolt

Material: Steel
Finish: Galvanized

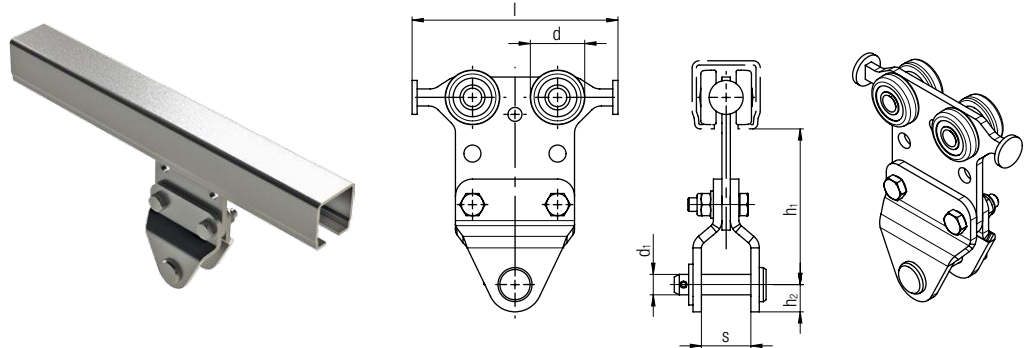

Technical Data		Part No.			
Rail Type		40 x 40	50 x 50	63 x 63	80 x 80
		145024	146024	147024	148024
Dimensions (mm)	s	29	29	40	40
	h ₁	16	16	22	22
	h ₂	92	87	107	101
	d	32	40	52	62
	d ₁	12	12	20	20
	l	120	120	160	160
Max. Load (kg)		100	160	250	400
Weight (kg)		0.75	0.85	1.0	1.2

Suspension Trolleys for Load Hooks – with Integrated Retainer

Material: Steel
Finish: Galvanized

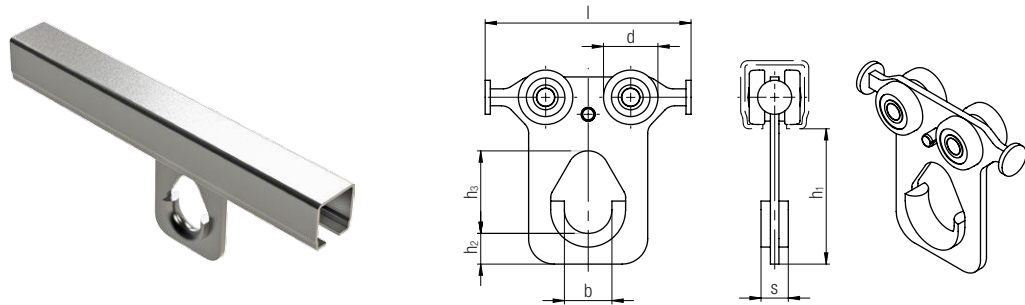

Technical Data		Part No.			
Rail Type		40 x 40	50 x 50	63 x 63	80 x 80
		145022	146022	147022	148022
Dimensions (mm)	s	28	28	28	28
	h ₁	80	75	91	85
	h ₂	16	16	22	22
	h ₃	48	48	48	48
	d	32	40	52	62
	l	120	120	160	160
	b	16	16	16	16
Max. Load (kg)		100	160	250	400
Weight (kg)		0.75	0.85	1.0	1.2

Suspension Trolleys – Special Design Program 1400

Suspension Trolleys with horizontal Guiding Rollers

Function: for extremely smooth cornering. Grinding of the track rollers on the rails' sidewalls is prevented by the guiding rollers, thus reducing the sliding resistance.

Dimensions of the Suspension Trolley must be adjusted to the radiuses present. Make sure there is only one type of radius when using this Suspension Trolley in the rail system. If switches are used, the radius is predetermined by the switch.

Available by request.



Traverse Trolleys Program 1400

Traverse Trolleys with Four Rollers – without Detent

Material: Steel
Finish: Galvanized

- Standard design, pendulum bolts
- High-temperature design, pendulum bolts
- Fall protection available by request
- Bumper shells are available with plastic protective strips by request

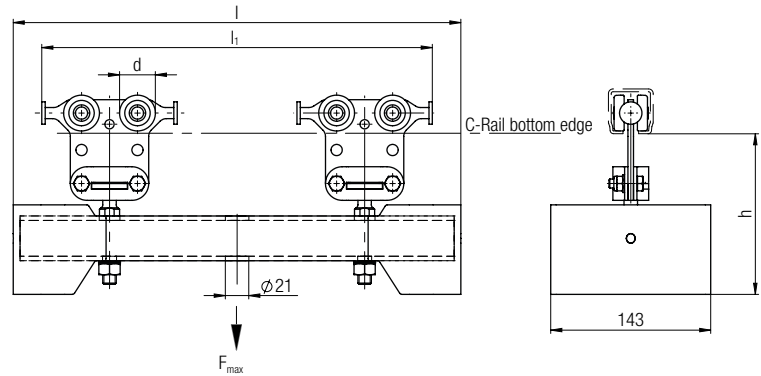

Version		Part No.			
Rail Type		40 x 40	50 x 50	63 x 63	80 x 80
Standard Design	l = 400	145025-0400	146025-0400	147025-0400	148025-0400
	l = 500	145025-0500	146025-0500	147025-0500	148025-0500
	l = 630	145025-0630	146025-0630	147025-0630	148025-0630
	l = 800	145025-0800	146025-0800	147025-0800	148025-0800
	l = 1000	145025-1000	146025-1000	147025-1000	148025-1000
High-temperature Design	l = 400	145125-0400	146125-0400	147125-0400	148125-0400
	l = 500	145125-0500	146125-0500	147125-0500	148125-0500
	l = 630	145125-0630	146125-0630	147125-0630	148125-0630
	l = 800	145125-0800	146125-0800	147125-0800	148125-0800
	l = 1000	145125-1000	146125-1000	147125-1000	148125-1000
Project Planning Dimensions (mm)	l ₁	l-52	l-52	l-12	l-12
	d	32	40	52	62
	h	145	140	155	149
Max. Load on Traverses F_{max} (kg)					
Traverse lengths (mm)	l = 400	200	320	400	500
	l = 500	200	320	400	500
	l = 630	200	320	400	500
	l = 800	200	320	400	400
	l = 1000	200	300	300	300

Traverse Trolleys Program 1400

Traverse Trolleys with Four Rollers – with Detent

Material: Steel
Finish: Galvanized

- Standard design, pendulum bolts
- High-temperature design, pendulum bolts
- Fall protection available by request
- Bumper shells are available with plastic protective strips by request

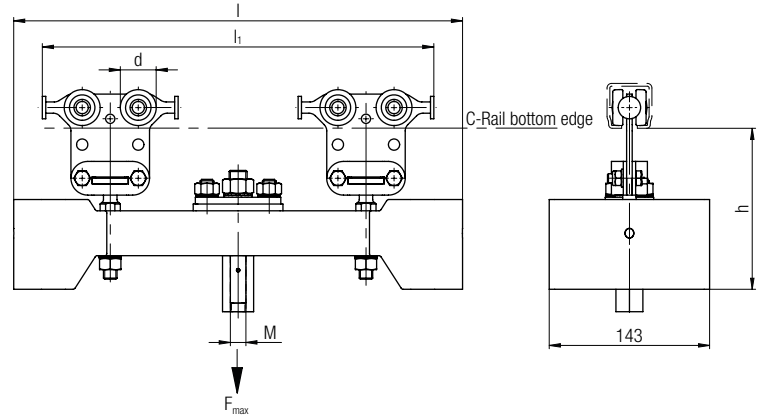

Version		Part No.				
Rail Type		40 x 40	50 x 50	63 x 63	80 x 80	
Standard Design	l = 400	145028-0400	146028-0400	147028-0400	148028-0400	
		145028-0400S	146028-0400S	147028-0400S	148028-0400S	
	l = 500	145028-0500	146028-0500	147028-0500	148028-0500	
		145028-0500S	146028-0500S	147028-0500S	148028-0500S	
	l = 630	145028-0630	146028-0630	147028-0630	148028-0630	
		145028-0630S	146028-0630S	147028-0630S	148028-0630S	
	l = 800	145028-0800	146028-0800	147028-0800	148028-0800	
		145028-0800S	146028-0800S	147028-0800S	148028-0800S	
	l = 1000	145028-1000	146028-1000	147028-1000	148028-1000	
		145028-1000S	146028-1000S	147028-1000S	148028-1000S	
	High-temperature Design	l = 400	145128-0400	146128-0400	147128-0400	148128-0400
			145128-0400S	146128-0400S	147128-0400S	148128-0400S
l = 500		145128-0500	146128-0500	147128-0500	148128-0500	
		145128-0500S	146128-0500S	147128-0500S	148128-0500S	
l = 630		145128-0630	146128-0630	147128-0630	148128-0630	
		145128-0630S	146128-0630S	147128-0630S	148128-0630S	
l = 800		145128-0800	146128-0800	147128-0800	148128-0800	
		145128-0800S	146128-0800S	147128-0800S	148128-0800S	
l = 1000		145128-1000	146128-1000	147128-1000	148128-1000	
		145128-1000S	146128-1000S	147128-1000S	148128-1000S	
Project Planning Dimensions (mm)		l _i	l-52	l-52	l-12	l-12
		d	32	40	52	62
	h	145	140	155	149	
	M	M14	M14	M16	M16	
Max. Load on Traverses F_{max} (kg)						
Traverse lengths (mm)	l = 400	200	320	400	500	
	l = 500	200	320	400	500	
	l = 630	200	320	400	500	
	l = 800	200	320	400	400	
	l = 1000	200	300	300	300	

Traverse Trolleys Program 1400

Traverse Trolleys with Four Rollers – with Eyelet

Material: Steel
Finish: Galvanized

- Standard design, pendulum bolts
- High-temperature design, pendulum bolts
- Fall protection available by request
- Bumper shells are available with plastic protective strips by request

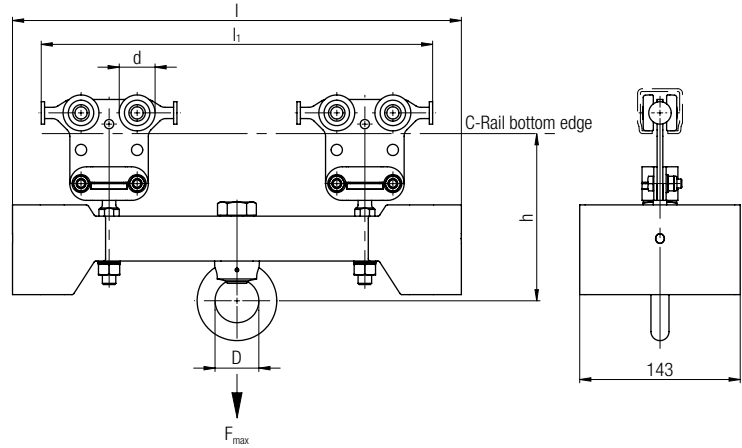

Version		Part No.			
Rail Type		40 x 40	50 x 50	63 x 63	80 x 80
Standard Design	l = 400	145026-0400	146026-0400	147026-0400	148026-0400
	l = 500	145026-0500	146026-0500	147026-0500	148026-0500
	l = 630	145026-0630	146026-0630	147026-0630	148026-0630
	l = 800	145026-0800	146026-0800	147026-0800	148026-0800
	l = 1000	145026-1000	146026-1000	147026-1000	148026-1000
High-temperature Design	l = 400	145126-0400	146126-0400	147126-0400	148126-0400
	l = 500	145126-0500	146126-0500	147126-0500	148126-0500
	l = 630	145126-0630	146126-0630	147126-0630	148126-0630
	l = 800	145126-0800	146126-0800	147126-0800	148126-0800
	l = 1000	145126-1000	146126-1000	147126-1000	148126-1000
Project Planning Dimensions (mm)	l ₁	l-52	l-52	l-12	l-12
	d	32	40	52	62
	h	150	145	160	154
	D	40	40	40	40
Max. Load on Traverses F_{max} (kg)					
Traverse lengths (mm)	l = 400	200	320	400	500
	l = 500	200	320	400	500
	l = 630	200	320	400	500
	l = 800	200	320	400	400
	l = 1000	200	300	300	300

Note: Max. valid line load of the C-Rails has to be verified!

Traverse Trolleys Program 1400

Traverse Trolleys with Two Rollers – with Traverse

Material: Steel
Finish: Galvanized

- Standard design, pendulum bolts
- High-temperature design, pendulum bolts

With or without detent 8 x 45°

Note: Recommended for straight tracks without curves.

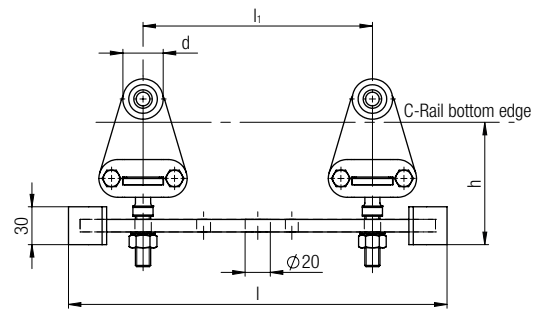
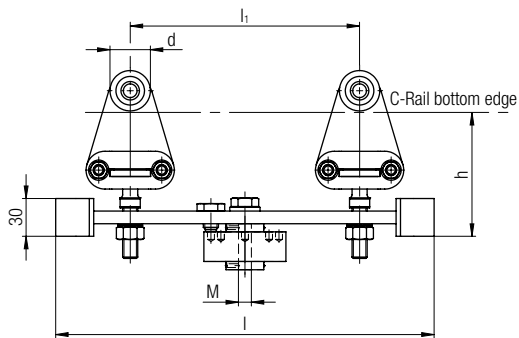

Technical Data		Part No.			
Rail Type		40 x 40	50 x 50	63 x 63	80 x 80
Standard Design with Detent		145018-..B	146018-..B	–	–
Standard Design without Detent		145015-..B	146015-..B	–	–
High-temperature Design with Detent		145118-..B	146118-..B	–	–
High-temperature Design without Detent		145115-..B	146115-..B	–	–
Dimensions (mm)	d	32	40	–	–
	h	95	90	–	–
	l	300	300	–	–
	l ₁	180	180	–	–
	M	M12 or M14	M12 or M14	–	–
Max. Load (kg)		100	125	–	–
Weight (kg)		2.7	2.8	–	–

Note: Please state thread size M. Ordering Example: **M12** requested – Part No.: 145018-12B

Traverse Trolleys Program 1400

Traverse Trolleys with Four Rollers – with Traverse

Material: Steel
Finish: Galvanized

- Standard design, pendulum bolts
- High-temperature design, pendulum bolts

With or without detent 8 x 45°

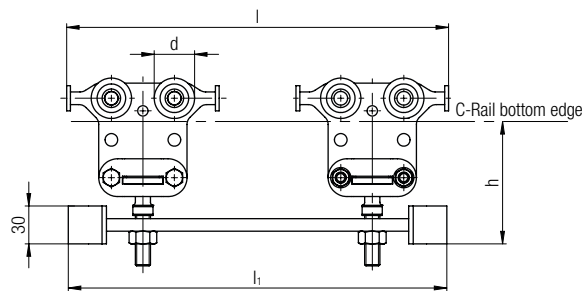
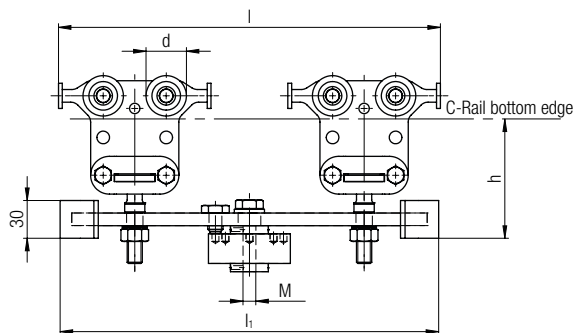

Technical Data		Part No.			
Rail Type		40 x 40	50 x 50	63 x 63	80 x 80
Standard Design with Detent		145028-..B	146028-..B	-	-
Standard Design without Detent		145025-..B	146025-..B	-	-
High-temperature Design with Detent		145128-..B	146128-..B	-	-
High-temperature Design without Detent		145125-..B	146125-..B	-	-
Dimensions (mm)	d	32	40	-	-
	h	95	90	-	-
	l	300	300	-	-
	l ₁	300	300	-	-
	M	M12 or M14	M12 or M14	-	-
Max. Load (kg)		200	250	-	-
Weight (kg)		3.2	3.3	-	-

Note: Please state thread size M. Ordering Example: **M12** requested – Part No.: 145028-12B

Latches

Program 1400

Latches – General Information

Depending on requirements and track system layout, numerous Latches and Stops need to be installed. These are actuated mechanically. Latches are used when the transported material has to be accumulated in sections, held before exit sections, or when it needs to be positioned at workstations.

Single-acting Latches



Rail Type	Part No.			
	40 x 40	50 x 50	63 x 63	80 x 80
	145911	146911	147911	148911

Latches with individual release

This Latch consists of two interconnected Latches. When actuated by using the handle, Latch B opens, and Latch A closes. This ensures that only one Traverse Trolley is released at a time.

Note:
Only suitable for Traverse Trolleys with 400 mm and 500 mm length, respectively.

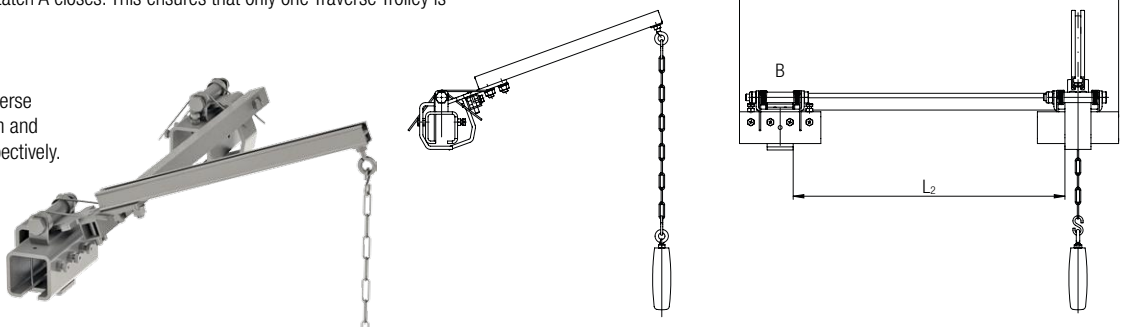

Rail Type		Part No.			
		40 x 40	50 x 50	63 x 63	80 x 80
		145921	146921	–	–
Dimensions (mm)	L ₁	583	421	–	–
	L ₂	618	421	–	–

Back-Stops

Prevents a Suspension Trolley from rolling back and ensures that the track is only drivable in one direction.

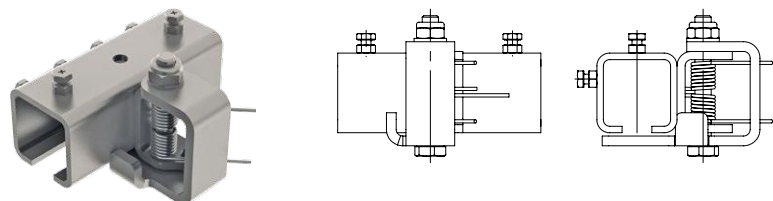

Rail Type		Part No.			
		40 x 40	50 x 50	63 x 63	80 x 80
		145913	146913	147913	148913

Overhead Monorail Systems Program 1400

Swivel Guides

For transiting, e.g. sliding gates, curtains, etc.

Pneumatic operation, limit of supply is the choke valve on the pneumatic cylinder.

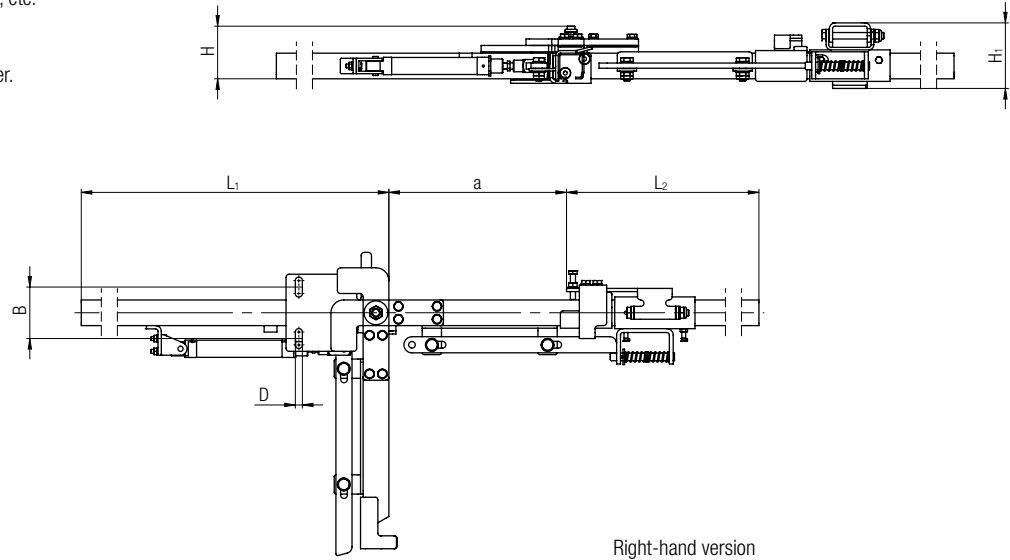

Rail Type		Part No.			
		40 x 40	50 x 50	63 x 63	80 x 80
		145951	146951	147951	148951
Dimensions (mm)	L ₁	1056	1066	1078	1085
	L ₂	1021	1021	1021	1021
	a	275	275	275	275
	B	80 ± 20	80 ± 20	130 ± 20	130 ± 20
	H	68	78	95	112
	H ₁	87	97	126	145
	D	11	11	13	13

Drag Chain Conveyors

Conveyors are used when the transport material needs to be hoisted for a section of the track (also in curves or inclines).
Standard Drag Chain Conveyors can be used for inclines of max. 15°.

For bigger inclines, the hinge of The Drag Chain Conveyor must be adjusted. Crucial parameters are: pitch angle, pitch radius, traverse length and height, etc.

Pitch radius and curve radius depend on the conveyor system.
Conveying speed up to 20 m/min (controlled by frequency converter), available with or without control unit.

Conveyors are manufactured individually for each application.

Please contact us for details.

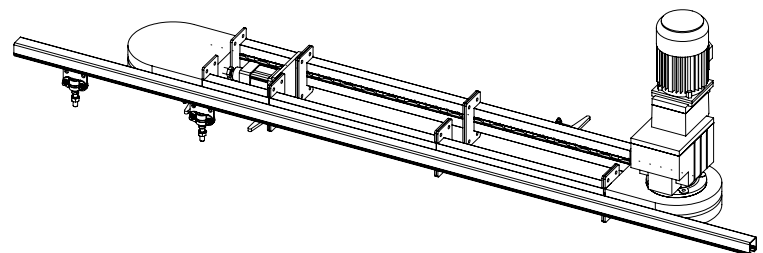
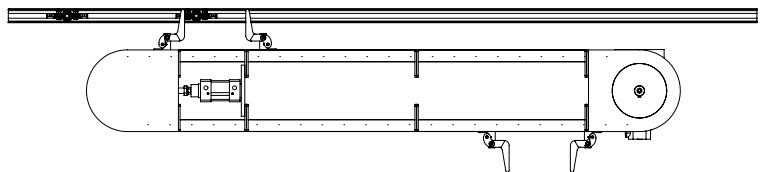

Overhead Monorail Systems Program 1400

Transfer Bridges with Latching Devices

Application:

For optimal use of space, especially in paint shops;
available as single, double, triple, or quintuple bridges.

- Latching Device released manually
- Includes Latching Device
- Arresters see page 44
- One or two-sided latching mechanism (diagram shows two-sided version)

Branch tracks with safety lockings have to be fitted with one Arrester each.
Safety lockings inbetween branch tracks have to be fitted on site on the steelwork.

Transfer Bridges are manufactured individually for each application.

Please contact us for details.

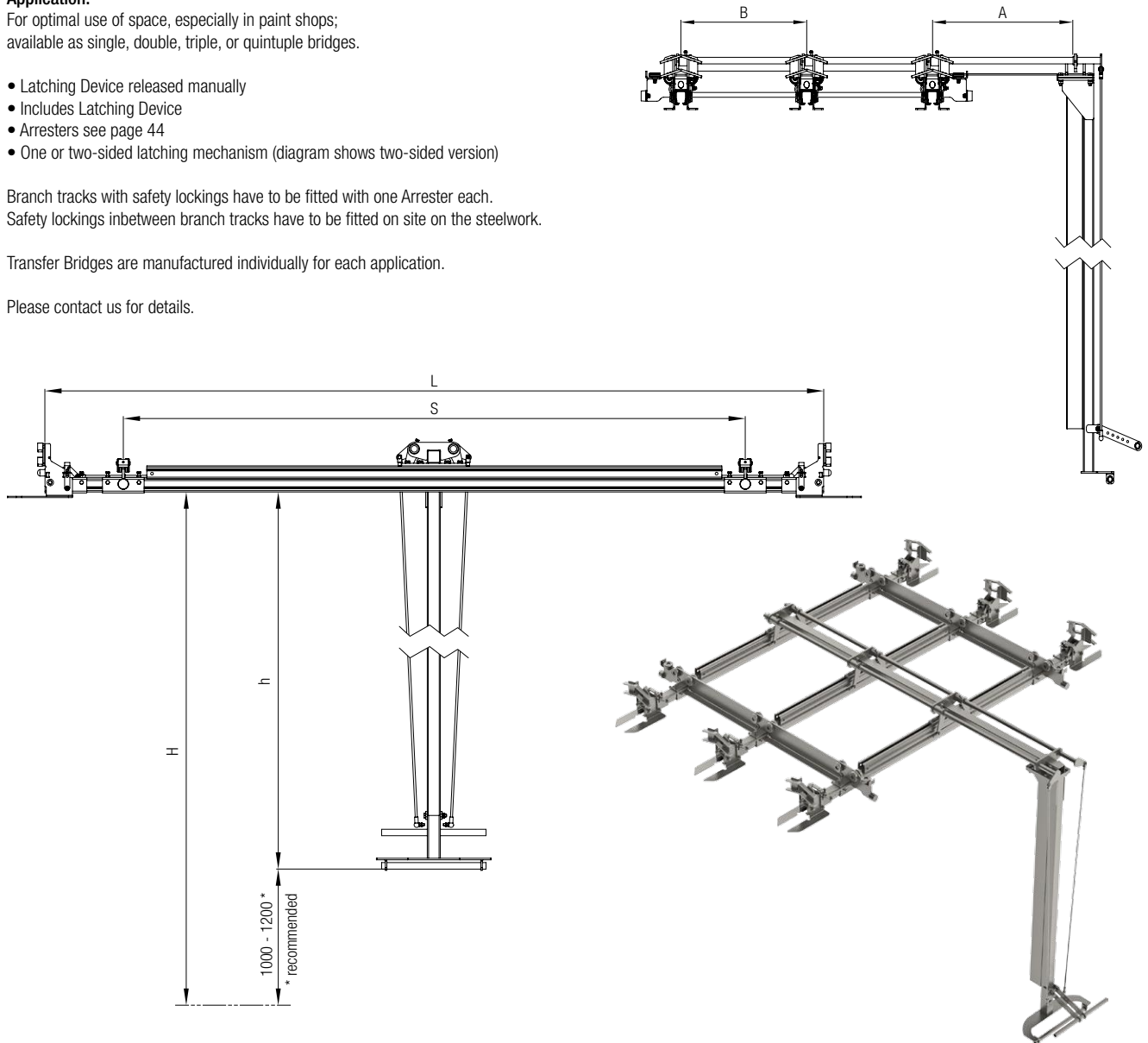

Rail Dimension (Branch Track/Main Track)	C40/C50, C50/C63, C63/80		
No. of Bridges	1, 2, 3, 5		
Latching Mechanism	One or Two-sided		
	Min.	Max.	Step Size
Bridge Length L (mm)	1500	3500	250
	3500	6000	500
Bridge Distance B (mm)	250	1000	50
Track Gauge S (mm)	Ideal Track Gauge will be calculated by us unless stated otherwise		
Branch Track Height H (mm)	–	4500	–
Operating Unit Height h (mm)	–	–	200
Operating Height (mm)	1000 (recommended)	1200 (recommended)	
Operating Unit Overhang A (mm)	$\frac{1}{2}$ Bridge Distance + 50	–	100
Max. Load in total (kg)	1000		

Overhead Monorail Systems Program 1400

Arresters

Used to position equipment transfer bridges on branch tracks.

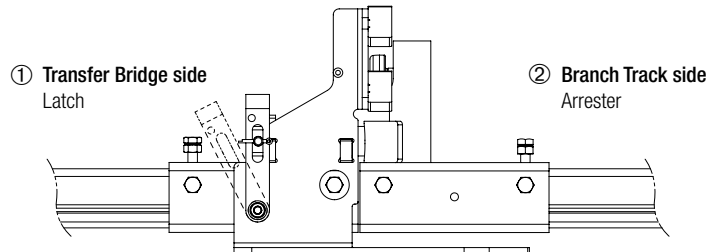

Single order of Pos. 2 if more than one branch track is to be connected to a transfer bridge.

Function:

Diagram 1 shows how the transfer bridge moves towards the branch track / Arrester.

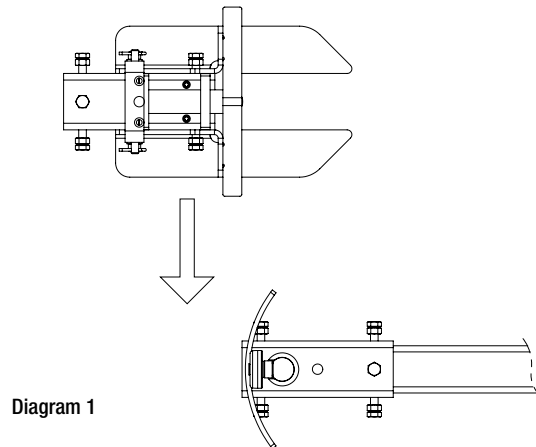
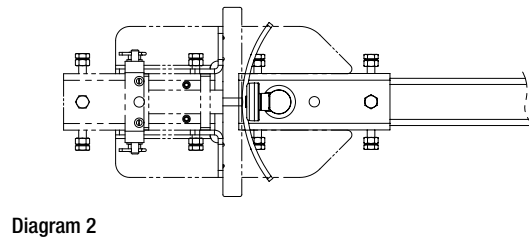

Diagram 2 shows the transfer bridge and the branch track interlocked.



Pos.	Part No.			
	40 x 40	50 x 50	63 x 63	80 x 80
① Latch	145963	146963	147963	148963
② Arrester	145964	146964	147964	148964

Overhead Monorail Systems Program 1400

Lifting and Lowering Stations

Preferred Use:

Lifting and lowering material, e.g. in degreasing / immersing baths, as well as in electroplating plants and paint shops, at loading and unloading stations, for machine tending and work station supply. Available in rail sizes 40, 50, 63 and 80.

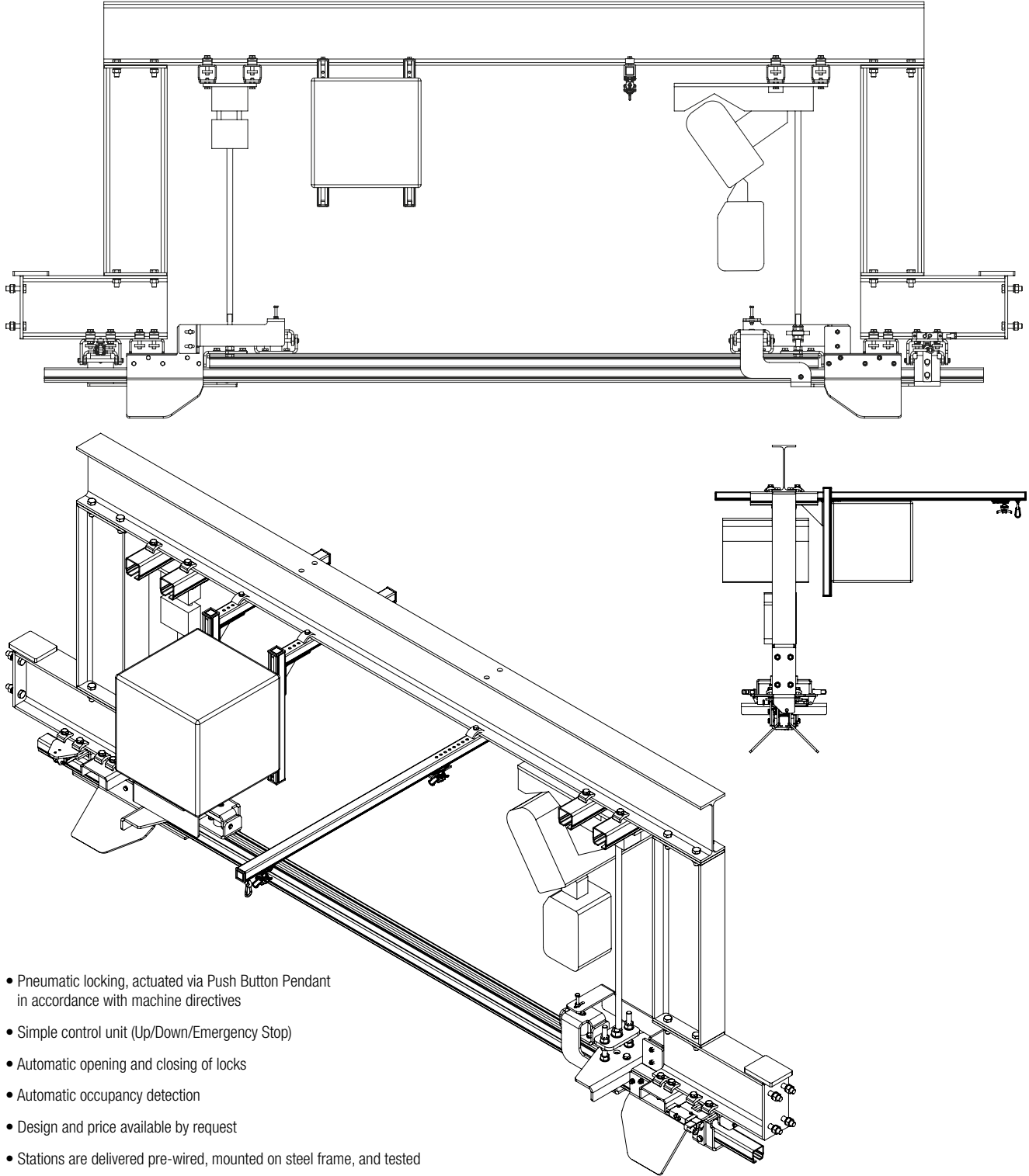

- Pneumatic locking, actuated via Push Button Pendant in accordance with machine directives
- Simple control unit (Up/Down/Emergency Stop)
- Automatic opening and closing of locks
- Automatic occupancy detection
- Design and price available by request
- Stations are delivered pre-wired, mounted on steel frame, and tested

Note:

Lifting and Lowering Stations are manufactured individually for each application. Maximum load capacity depending on configuration. Please contact us for details.

Project Planning Program 1400

Rail Mounting

When planning an Overhead Monorail System, the following has to be taken into account:

Position of rail joints

When the rail profiles are fully utilized, the spacing "x" must not exceed 200 mm.

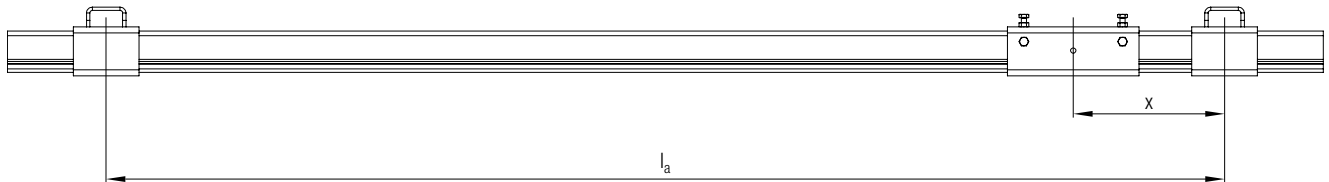

Mounting Curved Rail Segments

Curves and curve segments must be mounted at the crest of the curve.

When using curves with large radiuses, support distances " l_a " must be observed.

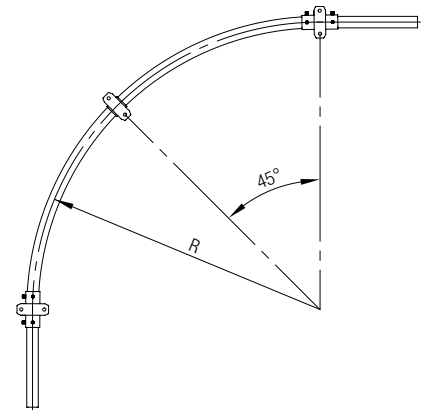

Choosing Suspension Trolleys

Suspension Trolleys with two rollers

These are applicable only when transported goods can be run individually, and the transported goods are allowed to buffer against each other.

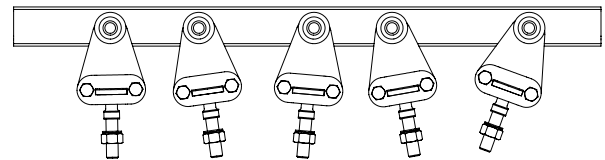

Suspension Trolleys with four rollers

Suspension Trolleys with four rollers are preferably used for smaller transported goods are allowed to buffer against each other safely.

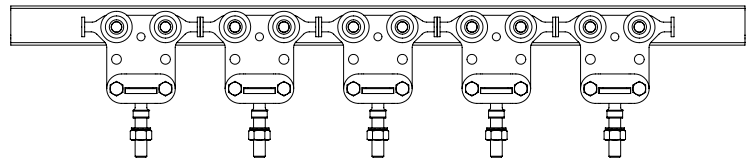

Suspension Trolleys with Traverses

We recommend using Suspension Trolleys with Traverses because they ensure safe transport. They offer optimal running characteristics when going through switches etc. and good utilization of the rails' load capacities. Multiple Trolleys can be moved in groups (depending on rail characteristics).

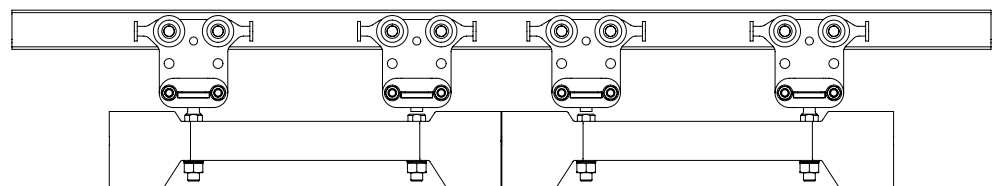

Note: Observe the accident prevention regulations for handling suspended loads.

Project Planning Program 1400

Determining the Valid Support Distance (Simplified Calculation Method)

Technical Data / Calculation Assumptions:

1. Beam on two supports, uniform load symmetrical to middle of the beam.

2. Valid deflection consisting of the distributed load plus net weight of the rail:

$$d_{zul} = \frac{l_A}{500}$$

3. Valid tension, without consideration of tension of flanges:

$$\sigma_{zul} = 100 \frac{N}{mm^2}$$

There are different kinds of load forces within an Overhead Monorail System.

A distinction is made between distributed loads and point loads. A distributed load occurs when several Suspension Trolleys are accumulated in one track section in short distances. A point load occurs if the load is distributed in greater distances on individual Suspension Trolleys. Thus, support distances can vary in different parts of the track system. Calculation of the valid support distances should be done by verifying the static values of the rails from case to case. We recommend contracting us to do the project planning for optimal results.

Load Diagram for Point Loads

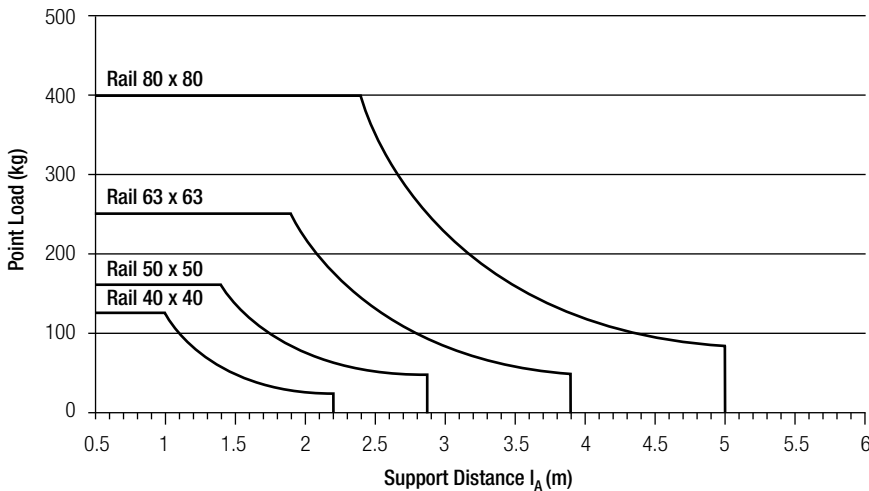

Note:

Overhead Monorail Systems Program 1400 are not designated for use with hoisting gears. In this case, different calculation bases apply, depending on the application.

Proof of structural strength must be provided by the customer.

Load Diagram for Distributed Loads (max. 1000 kg)

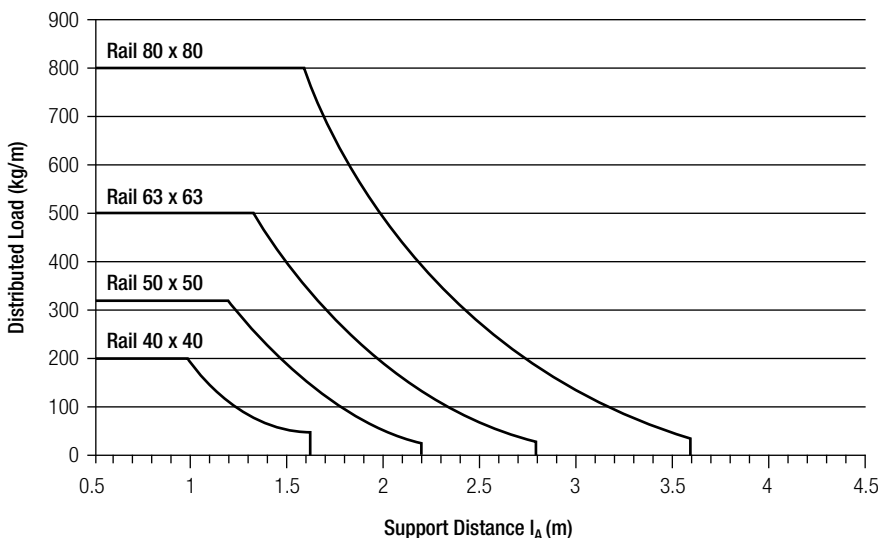

Example:

Weight of transported material = 50 kg
Weight of Suspension Trolley = 10 kg
Total Load = 60 kg

Suspension Trolleys with traverse length "L" = 300 mm are to be used.

The distributed load "F" is calculated as follows:

$$q = \frac{\text{Total load (kg)}}{\text{Length (m)}} = \frac{60 \text{ kg}}{0.3 \text{ m}} = 200 \frac{\text{kg}}{\text{m}}$$

According to the diagram support distances " l_A " are:

- 1.0 m for C-Rail 145005 or
- 1.45 m for C-Rail 146005 or
- 2.0 m for C-Rail 147005 and
- 2.66 m for C-Rail 148005.

With temperatures higher than 60°C, load carrying capacity is reduced:

- from 60° C to 100° C: approx. 15%
- from 100° C to 200° C: approx. 25%
- from 200° C to 250° C: approx. 40%

Project Planning Program 1400

Permissible Travel Speed (m/min) of Suspension Trolleys with Pendulum Bolts and End Stops inside the Rail

When Suspension Trolleys hit End Stops located inside the rail (also applies for Latches, Back-Stops, or the like), the inertia of the suspended loads cause high strain on the pendulum bolts. If the permissible strain is exceeded, bolts can break, causing the load to drop. Thus, depending on the distance of the mass of the load to its' pivotal point (e.g. an eyelet), the mass of the load itself, rail size, and size of the pendulum bolt, the following permissible travel speeds must be observed:

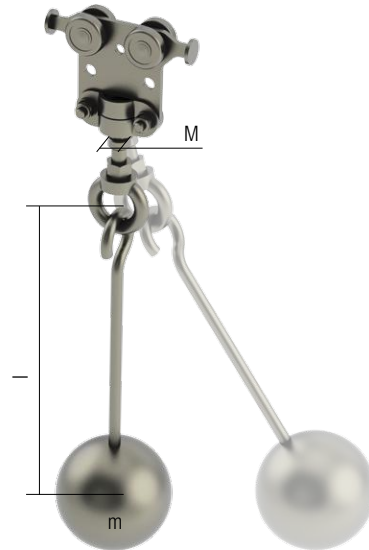

Permissible Travel Speed V_{zul} (m/min)

Rail Size		C40/C50					C63/C80					C63/C80				
Thread Size M		M12/M16					M16					M24				
l in m		0.1	0.16	0.25	0.4	≥ 0.63	0.1	0.16	0.25	0.4	≥ 0.63	0.1	0.16	0.25	0.4	≥ 0.63
m in kg	10	47	59	60	60	60	47	59	60	60	60	48	60	60	60	60
	12.5															
	16															
	20															
	25															
	31.5															
	40	45	55	56	40	49	45	56	38	47	57					
	50															
	63															
	80	37	46	48	54	40	49	51	56	38	47	57				
	100	32	40	48	48	40	49	51	56	38	47	57				
	125	29	36	43	54	40	49	51	56	38	47	57				
	160	27	32	39	48	40	49	51	56	38	47	57				
	200					40	49	51	56	38	47	57				
	250					40	49	51	56	38	47	57				
315					40	49	51	56	38	47	57					
400					40	49	51	56	38	47	57					
500					40	49	51	56	38	47	57					

Project Planning Program 1400

Permissible Travel Speed (m/min) of Traverse Trolleys with End Stops inside the Rail

When Traverse Trolleys hit End Stops located inside the rail (also applies for Latches, Back-Stops, or the like), the inertia of the suspended loads cause high strain on the pendulum bolts. If the permissible strain is exceeded, bolts can break, causing the load to drop. Thus, depending on the distance of the mass of the load to its' pivotal point (e.g. an eyelet), the mass of the load itself, rail size, and size of the pendulum bolt, the following permissible travel speeds must be observed:

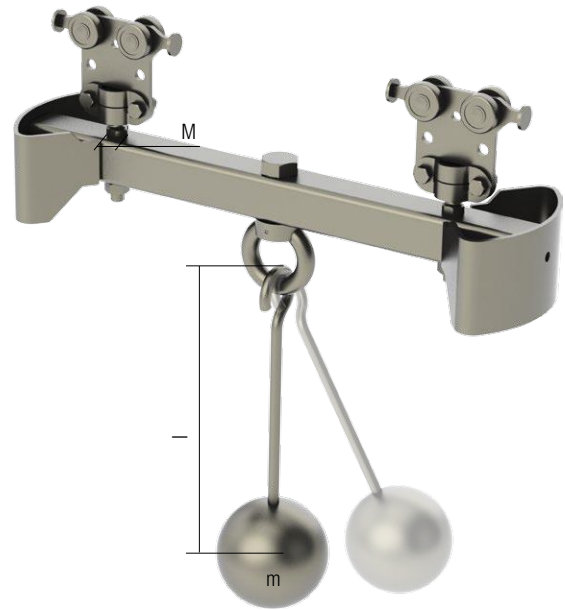

Permissible Travel Speed V_{zul} (m/min)

Rail Size		C40						C40/C50					C63/C80												
Thread Size M		M12						M16					M16						M24						
l in m		0*	0.1	0.16	0.25	0.4	≥ 0.63	0*	0.1	0.16	0.25	≥ 0.4	0*	0.1	0.16	0.25	0.4	0.63	≥ 1	0*	0.1	0.16	0.25	0.4	≥ 0.63
m in kg	10	13						22					21							37					
	12.5	11						20					19							33					
	16	10						18					17							29					
	20	9	45	58	60	60	60	16	45	58	60	60	15	45	58	60	60	60	60	26	45	58	60	60	60
	25	8						14					13							24					
	31.5	7						13					12							21					
	40	6						11					10							19					
	50	6						10					9							17					
	63	5	42					9					8							15					
	80	4	33	53				8					7							13					
	100	4	26	42				7					7							12					
	125	4	20	32	50			6					6							11					
	160	3	15	23	37	59		6	40				5	36	57					9					
	200	3	10	17	26	42		5	32	51			5	28	45					8					
	250							4	25	40			4	22	35	55				7					
	315							4	19	31	48		4	17	26	41				7					
400												3	12	19	29	47			6	41					
500												3	8	13	20	32	50		5	33	53				
630																			5	26	41				
800																			4	19	31	49			
1000																			4	15	23	36	58		

* load rigidly coupled to traverse



Service

Industry-specific competence

The scope and depth of Conductix-Wampfler services are tailored to the requirements and desires of our customers.

From project planning to long-term service contracts, most anything is possible.

The more complicated the system design and your expectations for lifetime and operational reliability, the more important regular service by our competent service team is.

Project planning

- Determining application parameters in discussion with the customer
- Selection of a suitable conveyor system
- Layout according to customer requirements, including all interfaces defined for material flow
- Software-supported process simulation

Assembly / installation

- Assembly of the overall system
- Complete installation
- Setup of the control system

Commissioning

- Commissioning performed by trained specialists
- Test operation and error case simulation
- Acceptance by customer
- Training and instruction on site



Service and maintenance

- Regular maintenance and inspection increase the lifetime of the system and ensure many years of availability
- Conductix-Wampfler service contracts: the "all-inclusive package"



From project planning, through pre-assembly, to installation on site, Conductix-Wampfler specialists are there for the customer - anywhere in the world!

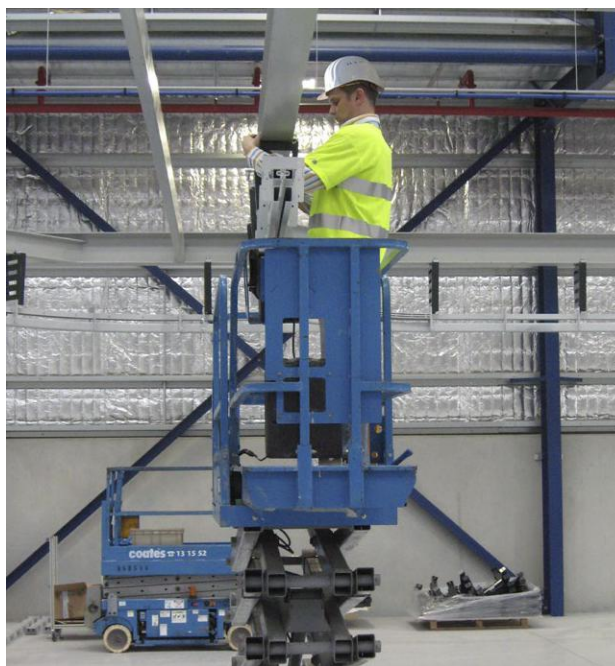

Your applications – our Solutions

Overhead Monorail Systems are just one component of the many solutions from the broad spectrum of Conductix-Wampfler energy, data, and handling systems. Which solution is the right one for your application always depends on the specific application situation. A combination of multiple Conductix-Wampfler products often provides very attractive advantages. Consulting and engineering competence are at your command in our companies and representatives around the world – as well as our solutions!



Cable reels

Motorized and spring cable reels from Conductix-Wampfler have their place wherever energy, data and media must travel a wide variety of distances in a short time – in any direction, quickly and safely.



Festoon systems

Conductix-Wampfler festoon systems are a fixed part of any industrial application: reliable and robust and available in an enormous variety of dimensions and variants.

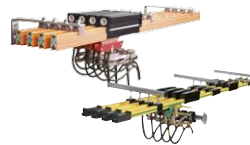

Conductor rails

Whether they're a box conductor rail or an extendible single-pole system, familiar Conductix-Wampfler conductor rails get people and material moving reliably.



Non-insulated conductor rails

Extremely robust, non-insulated conductor rails with copper head or stainless steel support surface are the ideal basis for harsh use e.g. in steel plants or ports.



Energy chains

The jack-of-all-trades when it comes to energy, data and media transfer. With the breadth of their product range, energy chains have a permanent place in industrial applications.



Slip ring bodies

Wherever things have to be smooth and round, tried and trusted slip ring bodies from Conductix-Wampfler provide interruption-free energy and data transmission. The focus here is on flexibility and reliability!



Inductive Power Transfer IPT®

The contact-free system for energy and data transmission. For high speeds absolutely free of wear.



Take-up reels and spring balancers

Whether for hoses or cables, as classic take-up reel or high-precision positioning aids for tools – take-up reels and spring balancers from Conductix-Wampfler take the load off you.



Jib booms

Installed with tool transporters, trolleys or complete media feed – safety and flexibility are brought together here when handling tough tasks.



Conveyor systems

Whether manual, semiautomatic or with Power & Free – a high degree of individuality is guaranteed when it comes to layout requirements and the place of use.

www.conductix.com

Conductix-Wampfler

has just one critical mission:
To provide you with energy and
data transmission systems that
will keep your operations up
and running 24/7/365.

To contact your nearest
sales office, please refer to:

[www.conductix.com/
contact-search](http://www.conductix.com/contact-search)



DELACHAUX GROUP