



# Container Weighing System

The Container Weighing System is designed to measure the load in each twistlock of single- and twinlift spreaders. (For tandem lift, one system per spreader is used).

Each sensor measures the load of a twistlock which is then sent into a central data processing unit from where the information is sent to the crane PLC and to the TOS.

The system also provides various signals to improve operational safeties and it allows to monitor twistlock and spreader life cycles.

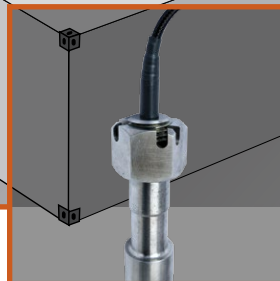
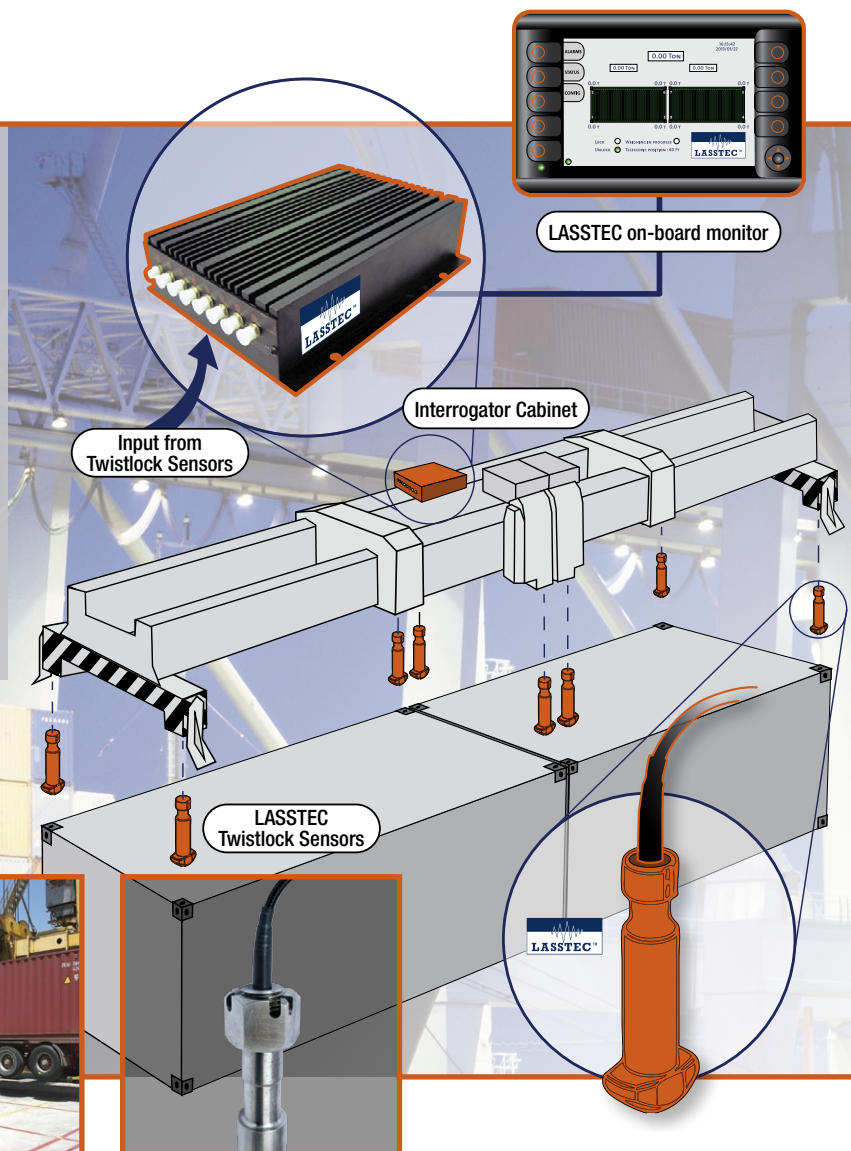

# Features & Specifications

- The system can be integrated into new and existing installations without modifying the spreaders.
- The sensor is inserted into a small hole drilled into the center of the twistlock. The hole is so small that it does not affect the structure of the twistlock.
- The sensors are totally insensitive to repetitive shock loads, vibrations, EMI, humidity and they resist very high overloads.
- Major spreader makers endorse the system and provide their twistlocks with the holes drilled.
- The data is processed on the spreader and sent through the spreader communication channel or sent parallel to the crane PLC and to the TOS.
- Monitors in the crane cabin can be added on an optional basis.
- No re-calibration is required throughout the life of the sensors.
- The sensors can be installed into the twistlocks by the customers.
- The system meets the new IMO (International Maritime Organization) requirements.

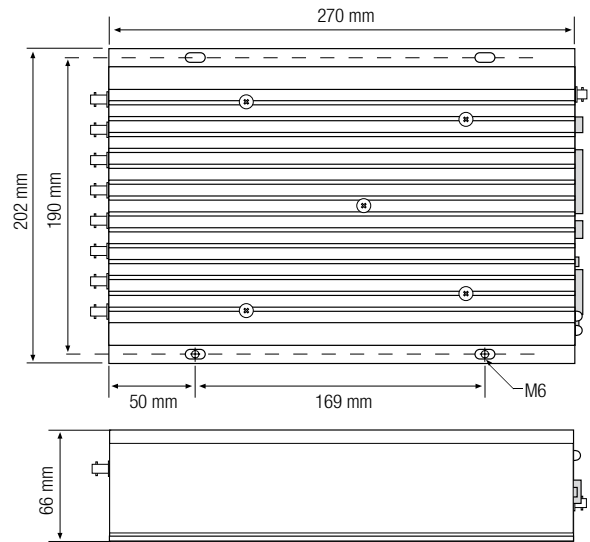

Technical Data	
Max. capacity reading per twistlock	100'000 kg
Load sampling rate per twistlock	50 Hz
Accuracy per twistlock	± 200 kg at F.S.
Interrogator Output Signals	CANopen DS301
	RS485 with Modbus protocol
	Profibus Module (optional)
Interrogator Output Data	Date and Time, Container size
	Load of each twistlock, Total load (Real time weight)
	Stabilized Container weight
	Load eccentricity (in X and y-axis)
	Peak load for each twistlock when lifting container, Total peak load
Alarm Data	Consult Conductix-Wampfler
Interrogator power source	24 VDC, 1 A (min 22.5 V DC/ max. 28.5 V DC)
Interrogator protection	IP55
Interrogator operating temperature range	-30°C to +60°C
Interrogator Humidity resistance	Max 90% at 40°C without condensation
Interrogator shock & vibration resistance	According to IEC 60068-2-6
Interrogator EMC resistance	EN 61000-6-2, EN 61000-6-3,
	EN 61000-4-2, DIN 40839-T1
Functionality indications with built-in LEDs	Power On/Off
	State of Interrogator functioning
Menu driven software and PC Interface	RS232 for calibration and Interrogator diagnostic
Interrogator weight	2 kg
Signals required from the spreader	Twistlocks locked
	Twistlocks unlocked
	Spreader in 20, 30, 40 and 45 ft positions
	Spreader in Twinlift mode

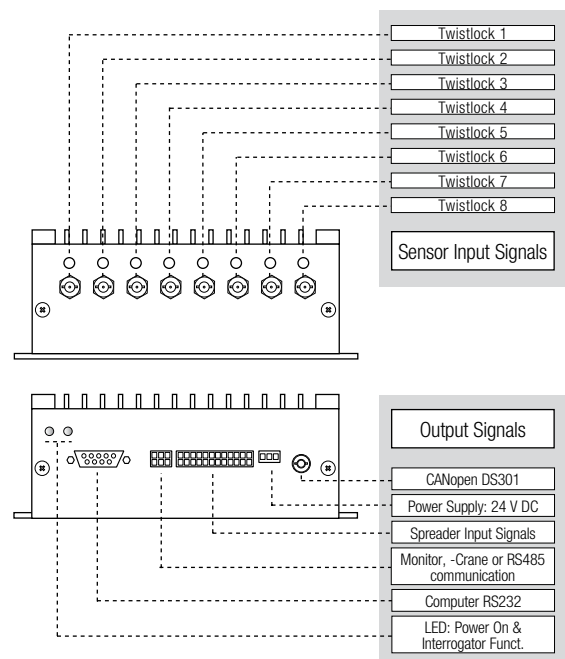

## Use LASSTEC to...

- Measure exact container weights in single and twinlift modes without interrupting the load cycle of the crane.
- Determine load eccentricity of single-, twinlift and Mobile Harbour Crane applications.
- Ensure all twistlocks are engaged when lifting a container.
- Prevent hoisting if one or more container corners are still locked to the stack on the vessel.
- Instant snag load detection.
- Detect and prevent accidental lifting of a road trailer still connected to a container in stacking yard applications.
- Monitor and record twistlock load cycles to optimize replacement intervals.
- Provide spreader and crane life cycle management and track overload situations.