

ME Series 1000M Ethernet Slip Rings

ME series(Ethernet/Gigabit slip ring) have been developed to provide reliable products to allow transfer of the 1000M/Gbit/Gigabit Ethernet protocol through a rotating interface. The innovative designs meet the challenge of matching impedance, controlling crosstalk and managing losses, and it works well at Gbit/1000M speed on CAT5/CAT6, Wide range of product solutions are offered with combinations of data and power in multiple mechanical configurations to meet your application needs.



Features

- Support GBit,10M/100M/1000M transmitting.
- Configured for Ethernet transmission
- RJ45 connector for direct plug-and-play
- High performance contact technology
- Available with multiple Ethernet, power and signal combinations

ME Series Models

Model#	ID(mm)	OD(mm)	100/1000M Ethernet	Mixed Power /Signal Circuits
ME1221	0	22	1	1~28
ME1222	0	22	2	1~20
ME2131	12.7	35	1	1~16
ME2132	12.7	35	2	1~12
ME2121	12.7	56	1	1~34
ME2122	12.7	56	2	1~32
ME2201	20	69	1	1~34
ME2202	20	69	2	1~32
ME2251	25.4	86	1	1~46
ME2252	25.4	86	2	1~38
ME2381	38.1	99	1	1~46
ME2382	38.1	99	2	1~38
ME2501	50	119	1	1~46
ME2502	50	119	2	1~38

60% of MOFLON's sales are customized solutions, please contact customer service for special requirements.

ME1221 100M/1000M Ethernet Slip Rings

1 channel 1000M Ethernet+ 1~16 power and signal channel

ME1221, support 1 channel 1000M ethernet slip rings, with compact OD 22mm, flange mounting, are standard, off-the-shelf, color-coded lead wires are used on both the stator and rotor for simplified electrical connections.

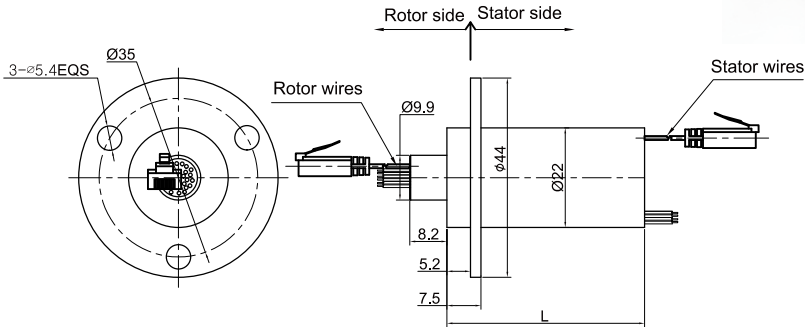

Part# Explanation

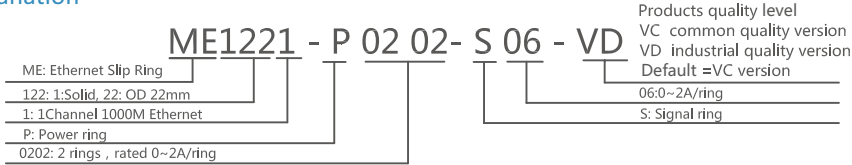

Specifications

Ethernet Specification			Mechanical Data	
Parameter	Value		Parameter	Value
1000M Ethernet	1 channel 1000M Ethernet		Working Life	See Product Quality Level Table
Connector	RJ45		Rotating Speed	See Product Quality Level Table
Ber Error Rate	10E-11		Working Temperature	-30°C~80°C
Electrical Data			Operating Humidity	0~85% RH
Parameter	Value		Contact Material	See Product Quality Level Table
	Power	Signal	Housing Material	Aluminium Alloy
Rated Voltage	0~440VAC/VDC	0~440VAC/VDC	Torque	0.1N.m, +0.03N.m/6 rings
Insulation Resistance	≥1000MΩ/500VDC	≥1000MΩ/500VDC	Protection Grade	IP51
Lead Wires	AWG28#Teflon	AAWG28# Teflon		
Lead Length	Standard 300mm(adjustable)			
Dielectric Strength	500VAC@50Hz,60s			
Electrical Noise	<0.01Ω			

Part# List

ME1221 Series Ethernet Slip Ring				
Part#	1000M Ethernet	4A	Signal or 2A	Length (mm)
ME1221-S16	1	0	16	43.6
ME1221-P0304-S10	1	3	10	43.6
ME1221-P0604-S04	1	6	4	43.6
ME1221-S28	1	0	28	57.3

Note:N channels 5A rings parallel can be used as 1 channel N*5A current. For example: 2 rings 5A parallel could be used as 1 wires 10A

Product Quality Level Table

Products Level Code	Max Rotating Speed	Working Life	Contact Material
VC	150RPM	10 Million Revs.	Precious Metal
VD	600RPM	20 Million Revs	Gold-plated

Lead Wires Color Code

Ring	1	2	3	4	5	6	7	8	9	10	11	12
Color	BLK	RED	YLW	GRN	BLU	WHT	BLK	RED	YLW	GRN	BLU	WHT

(6 wires for 1 group color, from 7-12, repeat the same color as 1...6, indicated with number code pipe)

ME1222 100M/1000M Ethernet Slip Rings

2 channels 1000M Ethernet+ 1~16 power and signal channel

ME1222, support 2 channels 1000M ethernet slip rings, with compact OD 22mm, flange mounting, are standard, off-the-shelf, color-coded lead wires are used on both the stator and rotor for simplified electrical connections.

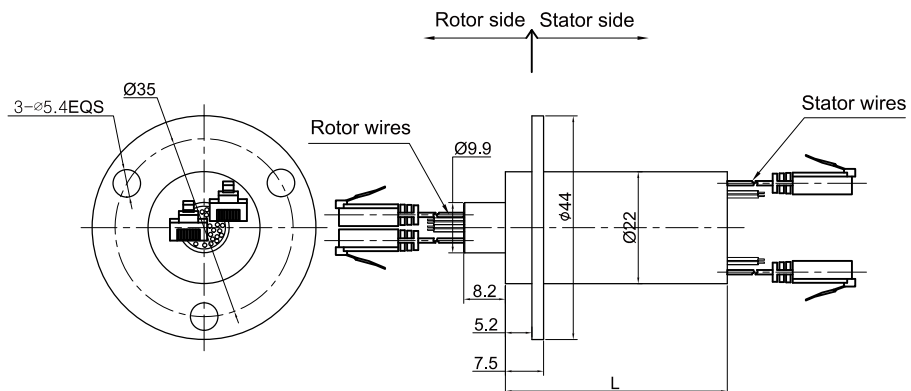

Part# Explanation

ME: Ethernet Slip Ring	ME1222	-	P	02	02-	S	06	-	VD	Products quality level VC common quality version VD industrial quality version Default =VC version
122: 1:Solid, 22: OD 22mm										06:0~2A/ring
2: 2 channels 1000M Ethernet										S: Signal ring
P: Power ring										
0202: 2 rings , rated 0~2A/ring										

Specifications

Ethernet Specification			
Parameter	Value		
1000M Ethernet	2 channels 1000M Ethernet		
Connector	RJ45		
Ber Error Rate	10E-11		
Electrical Data			
Parameter	Value		
	Power	Signal	
Rated Voltage	0~440VAC/VDC	0~440VAC/VDC	
Insulation Resistance	≥1000MΩ/500VDC	≥1000MΩ/500VDC	
Lead Wires	AWG28#Teflon	AWG28#Teflon	
Lead Length	Standard 300mm(adjustable)		
Dielectric Strength	500VAC@50Hz , 60s		
Electrical Noise	<0.01Ω		
Mechanical Data			
Parameter	Value		
Working Life	See Product Quality Level Table		
Rotating Speed	See Product Quality Level Table		
Working Temperature	-30°C~80°C		
Operating Humidity	0~85% RH		
Contact Material	See Product Quality Level Table		
Housing Material	Aluminium Alloy		
Torque	0.1N.m ; +0.03N.m/6 rings		
Protection Grade	IP51		

Part# List

ME1222 Series Ethernet Slip Ring				
Part#	1000M Ethernet	4A	Signal or 2A	Length (mm)
ME1222-S08	2	0	8	43.6
ME1222-P0304-S02	2	3	2	43.6
ME1222-S20	2	0	20	57.3

Note: N channels 5A rings parallel can be used as 1 channel N*5A current. For example: 2 rings 5A parallel could be used as 1 wires 10A

Product Quality Level Table

Products Level Code	Max Rotating Speed	Working Life	Contact Material
VC	150RPM	10 Million Revs.	Precious Metal
VD	600RPM	20 Million Revs	Gold-plated

Lead Wires Color Code

Ring	1	2	3	4	5	6	7	8	9	10	11	12
Color	BLK	RED	YLW	GRN	BLU	WHT	BLK	RED	YLW	GRN	BLU	WHT

(6 wires for 1 group color, from 7-12, repeat the same color as 1...6, indicated with number code pipe)

Options for custom slip ring

Note: Below special demands can be customized. According, the delivery date will be extended 3 to 15 days; also the cost will be increased 30% to 50%. Most of our basic parts are standard and modular, which can save the cost and lead time.

- ① Cable exit way and cable length can be customized for both rotor and stator.
- ② Because of the structure limitation, length/height/OD can be customized on your request.
- ③ Support current or signal up to 200 rings.
- ④ Aviation plug, terminal and heat-shrink tube are optional.
- ⑤ Hybrid slip ring for Yaskawa/Panasonic/Siemens servo control signal, power line and encoder line.
- ⑥ Support mixed high speed data transmission (including Ethernet, USB, RS232, RS485, Profibus, CanBUS, CANOPEN, DeviceNET, CC-LINK, ProfiNET, EtherCAT, etc.)
- ⑦ Can combine temperature control signal with thermocouple signal.
- ⑧ Special environment can be customized, such as quakeproof, high temperature, etc.
- ⑨ Hybrid Pneumatic/hydraulic and electric slip ring can be mixed.
- ⑩ High temperature can up to 500 degrees.
- ⑪ High pressure can up to 110KV
- ⑫ Rotating speed can up to 10000RPM
- ⑬ Maximum current can up to 5000 amperes.
- ⑭ Military grade
- ⑮ Optional for underwater IP65, IP68.
- ⑯ Optional for stainless steel housing

Technical support: technical@moflon.com

ME2131 100M/1000M Ethernet Slip Rings

1 channel 1000M Ethernet+ 1~16 power and signal channel

ME2131, support 1 channel 1000M ethernet slip rings, with through bore size 12.7mm(0.5"), overall diameter 33mm, are standard, off-the-shelf, color-coded lead wires are used on both the stator and rotor for simplified electrical connections.

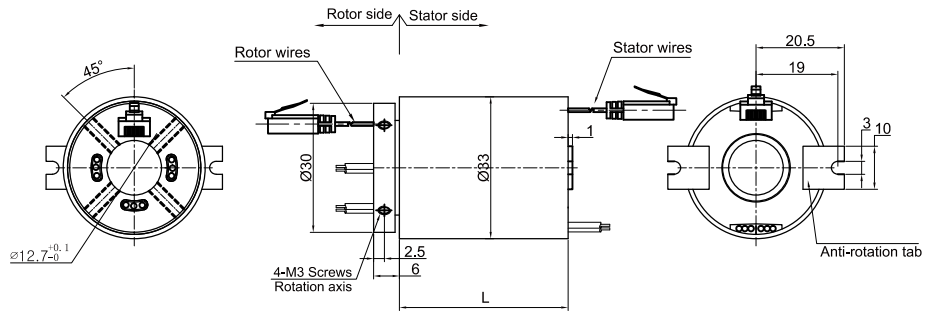

Part# Explanation

ME: Ethernet Slip Ring	ME2131	-	P	02	05-	S	06	-	VD	Products quality level
213: ID 12.7mm, OD 35										VC common quality version
1: 1 Channel 1000M Ethernet										VD industrial quality version
P: Power ring										Default =VC version
0205: 2 rings, rated 0~2A/ring										06:0~2A/ring
										S: Signal ring

Specifications

Ethernet Specification	
Parameter	Value
1000M Ethernet	1 channel 1000M Ethernet
Connector	RJ45
Ber Error Rate	10E-11
Electrical Data	
Parameter	Value
	Power
Rated Voltage	0~440VAC/VDC
Insulation Resistance	≥1000MΩ/500VDC
Lead Wires	AWG22#Teflon
Lead Length	Standard 300mm(adjustable)
Dielectric Strength	500VAC@50Hz, 60s
Electrical Noise	<0.01Ω
	Signal
Rated Voltage	0~440VAC/VDC
Insulation Resistance	≥1000MΩ/500VDC
Lead Wires	AWG22#Teflon
Mechanical Data	
Parameter	Value
Working Life	See Product Quality Level Table
Rotating Speed	See Product Quality Level Table
Working Temperature	-30°C~80°C
Operating Humidity	0~85% RH
Contact Material	See Product Quality Level Table
Housing Material	Aluminium Alloy
Torque	0.1N.m ; +0.03N.m/6 rings
Protection Grade	IP51

Part# List

ME2131 Series Ethernet Slip Ring			
Part#	1000M Ethernet	Signal 5A	Length (mm)
ME2131-S04	1	4	39.2
ME2131-S10	1	10	53

Note:1) N channels 5A rings parallel can be used as 1 channel N*5A current. For example: 2 rings 5A parallel could be used as 1 wires 10A.
2) Circuit number and current strength can be customized, please contact customer service for more details.

Product Quality Level Table

Products Level Code	Max Rotating Speed	Working Life	Contact Material
VC	150RPM	20 Million Revs	Precious Metal
VD	600RPM	80 Million Revs	Gold-plated

Lead Wires Color Code

Ring	1	2	3	4	5	6	7	8	9	10	11	12
Color	BLK	RED	YLW	GRN	BLU	WHT	BLK	RED	YLW	GRN	BLU	WHT

(6 wires for 1 group color, from 7-12, repeat the same color as 1..6, indicated with number code pipe)

Options for custom slip ring

Note: Below special demands can be customized. According, the delivery date will be extended 3 to 15 days; also the cost will be increased 30% to 50%. Most of our basic parts are standard and modular, which can save the cost and lead time.

- ① Bore diameter can be customized, cable exit way and cable length can be customized for both rotor and stator.
- ② Because of the structure limitation, length/height/OD can be customized on your request.
- ③ Support current or signal up to 200 rings.
- ④ Aviation plug, terminal and heat-shrink tube are optional.
- ⑤ Hybrid slip ring for Yaskawa/Panasonic/Siemens servo control signal, power line and encoder line.
- ⑥ Support mixed high speed data transmission (including Ethernet, USB, RS232, RS485, Profibus, CanBUS, CANOPEN, DeviceNET, CC-LINK, ProfiNET, EtherCAT, etc.)
- ⑦ Can combine temperature control signal with thermocouple signal.
- ⑧ Special environment can be customized, such as quakeproof, high temperature, etc.
- ⑨ Hybrid Pneumatic/hydraulic and electric slip ring can be mixed.
- ⑩ High temperature can up to 500 degrees.
- ⑪ High pressure can up to 110KV
- ⑫ Rotating speed can up to 10000RPM
- ⑬ Maximum current can up to 5000 amperes.
- ⑭ Military grade
- ⑮ Optional for underwater IP65, IP68.
- ⑯ Optional for stainless steel housing

Technical support: technical@moflon.com

ME2132 100M/1000M Ethernet Slip Rings

2 channels 1000M Ethernet+ 1~16 power and signal channel

ME2132, support 2 channels 1000M ethernet slip rings, with through bore size 12.7mm(0.5"), overall diameter 33mm, are standard, off-the-shelf, Color-coded lead wires are used on both the stator and rotor for simplified electrical connections.

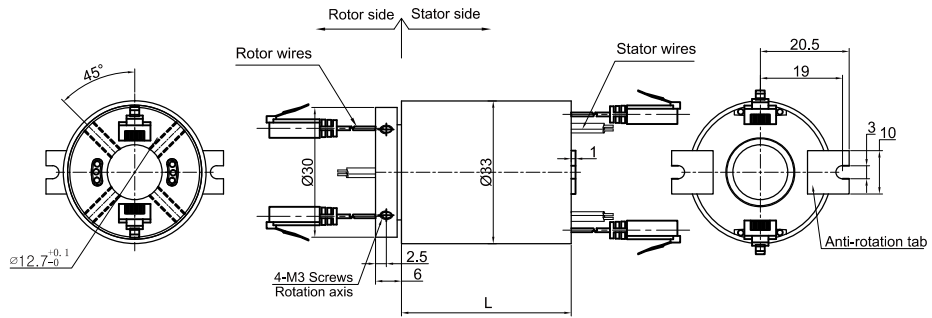

Part# Explanation

ME: Ethernet Slip Ring	ME2132	-	P	02	05-	S	06	-	VD	Products quality level
213: ID 12.7mm, OD 35										VC common quality version
2: 2 Channels 1000M Ethernet										VD industrial quality version
P: Power ring										Default =VC version
0205: 2 rings , rated 0~2A/ring										06:0~2A/ring
										S: Signal ring

Specifications

Ethernet Specification			
Parameter	Value		
1000M Ethernet	2 channels 1000M Ethernet		
Connector	RJ45		
Bit Error Rate	10E-11		
Electrical Data			
Parameter	Value		
	Power	Signal	
Rated Voltage	0~440VAC/VDC	0~440VAC/VDC	
Insulation Resistance	≥1000MΩ/500VDC	≥1000MΩ/500VDC	
Lead Wires	AWG22#Teflon	AWG22#Teflon	
Lead Length	Standard 300mm(adjustable)		
Dielectric Strength	500VAC@50Hz , 60s		
Electrical Noise	<0.01Ω		
Mechanical Data			
Parameter	Value		
Working Life	See Product Quality Level Table		
Rotating Speed	See Product Quality Level Table		
Working Temperature	-30°C~80°C		
Operating Humidity	0~85% RH		
Contact Material	See Product Quality Level Table		
Housing Material	Aluminium Alloy		
Torque	0.1N.m ; +0.03N.m/6 rings		
Protection Grade	IP51		

Part# List

ME2132 Series Ethernet Slip Ring			
Part#	1000M Ethernet	Signal 5A	Length (mm)
ME2132-S02	2	2	53
ME2132-S08	2	8	66.8

Note:1) N channels 5A rings parallel can be used as 1 channel N*5A current. For example: 2 rings 5A parallel could be used as 1 wires 10A.
2) Circuit number and current strength can be customized, please contact customer service for more details.

Product Quality Level Table

Products Level Code	Max Rotating Speed	Working Life	Contact Material
VC	150RPM	20 Million Revs	Precious Metal
VD	600RPM	80 Million Revs	Gold-plated

Lead Wires Color Code

Ring	1	2	3	4	5	6	7	8	9	10	11	12
Color	BLK	RED	YLW	GRN	BLU	WHT	BLK	RED	YLW	GRN	BLU	WHT

(6 wires for 1 group color, from 7-12, repeat the same color as 1...6, indicated with number code pipe)

Options for custom slip ring

Note: Below special demands can be customized. According, the delivery date will be extended 3 to 15 days; also the cost will be increased 30% to 50%. Most of our basic parts are standard and modular, which can save the cost and lead time.

- ① Bore diameter can be customized, cable exit way and cable length can be customized for both rotor and stator.
 - ② Because of the structure limitation, length/height/OD can be customized on your request.
 - ③ Support current or signal up to 200 rings.
 - ④ Aviation plug, terminal and heat-shrink tube are optional.
 - ⑤ Hybrid slip ring for Yaskawa/Panasonic/Siemens servo control signal, power line and encoder line.
 - ⑥ Support mixed high speed data transmission (including Ethernet, USB, RS232, RS485, Profibus, CanBUS, CANOPEN, DeviceNET, CC-LINK, ProfiNET, EtherCAT, etc.)
 - ⑦ Can combine temperature control signal with thermocouple signal.
 - ⑧ Special environment can be customized, such as quakeproof, high temperature, etc.
 - ⑨ Hybrid Pneumatic/hydraulic and electric slip ring can be mixed.
 - ⑩ High temperature can up to 500 degrees.
 - ⑪ High pressure can up to 110KV
 - ⑫ Rotating speed can up to 10000RPM
 - ⑬ Maximum current can up to 5000 amperes.
 - ⑭ Military grade
 - ⑮ Optional for underwater IP65, IP68.
 - ⑯ Optional for stainless steel housing
- Technical support: technical@moflon.com

ME2121 100M/1000M Ethernet Slip Rings

1 channel 1000M Ethernet+ 1~16 power and signal channel

ME2121, support 2 channels 1000M ethernet slip rings, with through bore size 12.7mm(0.5"), overall diameter 56mm, are standard, off-the-shelf, Color-coded lead wires are used on both the stator and rotor for simplified electrical connections.

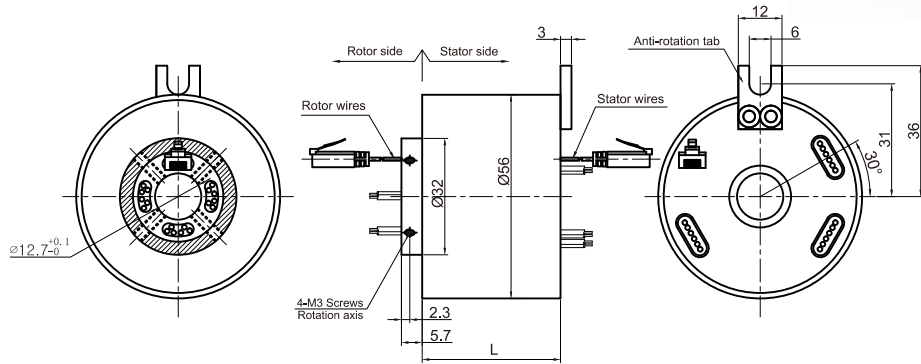

Part# Explanation

ME2121 - P 02 10- S 06 - VD		Products quality level
ME: Ethernet Slip Ring		VC common quality version
212: ID 12.7mm, OD 56		VD industrial quality version
1: 1 Channel 1000M Ethernet		Default = VC version
P: Power ring		06: 0~2A/ring
0210: 2 rings , rated 0~2A/ring		S: Signal ring

Specifications

Ethernet Specification		
Parameter	Value	
1000M Ethernet	1 channel 1000M Ethernet	
Connector	RJ45	
Ber Error Rate	10E-11	
Electrical Data		
Parameter	Value	
	Power	Signal
Rated Voltage	0~440VAC/VDC	0~440VAC/VDC
Insulation Resistance	≥1000MΩ/500VDC	≥1000MΩ/500VDC
Lead Wires	AWG16#Teflon/PVC/Silicon	AWG22#Teflon
Lead Length	Standard 300mm(adjustable)	
Dielectric Strength	500VAC@50Hz , 60s	
Electrical Noise	<0.01Ω	
Mechanical Data		
Parameter	Value	
Working Life	See Product Quality Level Table	
Rotating Speed	See Product Quality Level Table	
Working temperature	-30°C~80°C	
Operating Humidity	0~85% RH	
Contact Material	See Product Quality Level Table	
Housing Material	Aluminium Alloy	
Torque	0.1N.m ; +0.03N.m/6 rings	
Protection Grade	IP51	

Part# List

ME2121 Series Ethernet Slip Ring											
Part#	1000M Ethernet	10A	20A	Signal 5A	Length (mm)	Part#	1000M Ethernet	10A	20A	Signal 5A	Length (mm)
ME2121-S04	1	0	0	4	54.8	ME2121-P0210-S14	1	2	0	14	88.4
ME2121-P0410	1	4	0	0	54.8	ME2121-P0410-S12	1	4	0	12	88.4
ME2121-P0420	1	0	4	0	71.5	ME2121-P0610-S10	1	6	0	10	88.4
ME2121-S10	1	0	0	10	71.5	ME2121-P0810-S08	1	8	0	8	88.4
ME2121-P0210-S08	1	2	0	8	71.5	ME2121-P1010-S06	1	10	0	6	88.4
ME2121-P0410-S06	1	4	0	6	71.5	ME2121-P1210-S04	1	12	0	4	88.4
ME2121-P0610-S04	1	6	0	4	71.5	ME2121-S22 *	1	0	0	22	105.2
ME2121-P1010	1	10	0	0	71.5	ME2121-S28 *	1	0	0	28	125
ME2121-S16	1	0	0	16	88.4	ME2121-S34 *	1	0	0	34	141.8

Note:1) Please contact customer service for drawing(marked by asterisks "**").

2) According to your own needs, 10A, 20A and 5A can be combined freely. Please contact customer service if you need over 2 channels Ethernet.

3) N channels 10A rings parallel can be used as 1 channel N*10A current. For example: 2 rings 10A parallel could be used as 1 wires 20A

Product Quality Level Table

Products Level Code	Max Rotating Speed	Working Life	Contact Material
VC	150RPM	20 Million Revs	Precious Metal
VD	600RPM	80 Million Revs	Gold-plated

Lead Wires Color Code

Ring	1	2	3	4	5	6	7	8	9	10	11	12
Color	BLK	RED	YLW	GRN	BLU	WHT	BLK	RED	YLW	GRN	BLU	WHT

(6 wires for 1 group color, from 7-12, repeat the same color as 1...6, indicated with number code pipe)

Options for custom slip ring

Note: Below special demands can be customized. According, the delivery date will be extended 3 to 15 days; also the cost will be increased 30% to 50%. Most of our basic parts are standard and modular, which can save the cost and lead time.

- ① Bore diameter can be customized,cable exit way and cable length can be customized for both rotor and stator.
- ② Because of the structure limitation, length/height/OD can be customized on your request.
- ③ Support current or signal up to 200 rings.
- ④ Aviation plug, terminal and heat-shrink tube are optional.
- ⑤ Hybrid slip ring for Yaskawa/Panasonic/Siemens servo control signal, power line and encoder line.
- ⑥ Support mixed high speed data transmission (including Ethernet, USB, RS232, RS485, Profibus, CanBUS, CANOPEN, DeviceNET, CC-LINK, ProfiNET, EtherCAT, etc.)
- ⑦ Can combine temperature control signal with thermocouple signal.
- ⑧ Special environment can be customized, such as quakeproof, high temperature, etc.
- ⑨ Hybrid Pneumatic/hydraulic and electric slip ring can be mixed.
- ⑩ High temperature can up to 500 degrees.
- ⑪ High pressure can up to 110KV
- ⑫ Rotating speed can up to 10000RPM
- ⑬ Maximum current can up to 5000 amperes.
- ⑭ Military grade
- ⑮ Optional for underwater IP65, IP68.
- ⑯ Optional for stainless steel housing

Technical support: technical@moflon.com

ME2122 100M/1000M Ethernet Slip Rings

2 channels 1000M Ethernet+ 1~16 power and signal channel

ME2122, support 2 channels 1000M ethernet slip rings, with through bore size 12.7mm(0.5"), overall diameter 56mm, are standard, off-the-shelf, Color-coded lead wires are used on both the stator and rotor for simplified electrical connections.

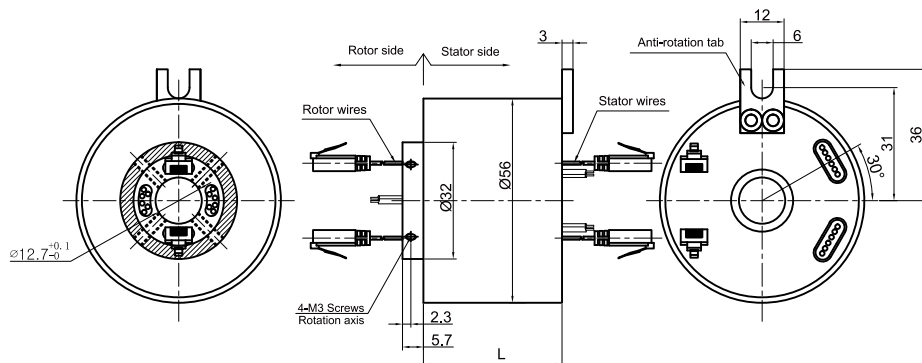

Part# Explanation

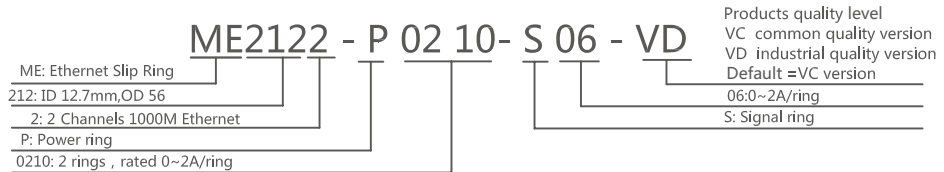

Specifications

Ethernet Specification			
Parameter	Value		
1000M Ethernet	2 channels 1000M Ethernet		
Connector	RJ45		
Ber Error Rate	10E-11		
Electrical Data			
Parameter	Value		
	Power	Signal	
Rated Voltage	0~440VAC/VDC	0~440VAC/VDC	
Insulation Resistance	$\geq 1000\text{M}\Omega/500\text{VDC}$	$\geq 1000\text{M}\Omega/500\text{VDC}$	
Lead Wires	AWG16#Teflon	AWG22#Teflon	
Lead Length	Standard 300mm(adjustable)		
Dielectric Strength	500VAC@50Hz, 60s		
Electrical Noise	<0.01 Ω		
Mechanical Data			
Parameter	Value		
Working Life	See Product Quality Level Table		
Rotating Speed	See Product Quality Level Table		
Working temperature	-30°C~80°C		
Operating Humidity	0~85% RH		
Contact Material	See Product Quality Level Table		
Housing Material	Aluminium Alloy		
Torque	0.1N.m ; +0.03N.m/6 rings		
Protection Grade	IP51		

Part# List

ME2122 Series Ethernet Slip Ring											
Part#	1000M Ethernet	10A	20A	Signal 5A	Length (mm)	Part#	1000M Ethernet	10A	20A	Signal 5A	Length (mm)
ME2122-S02	2	0	0	2	71.5	ME2122-S14	2	0	0	14	105.2
ME2122-P0210	2	2	0	0	71.5	ME2122-P0410-S10	2	4	0	10	105.2
ME2122-P0420	2	0	4	0	88.4	ME2122-P0610-S08	2	6	0	8	105.2
ME2122-S08	2	0	0	8	88.4	ME2122-P1010-S04	2	10	0	4	105.2
ME2122-P0810	2	8	0	0	88.4	ME2122-S20	2	0	0	20	122
ME2122-P0210-S06	2	2	0	6	88.4	ME2122-S26	2	0	0	26	138.8
ME2122-P0410-S04	2	4	0	4	88.4	ME2122-S32	2	0	0	32	155.6

Note: 1) N channels 10A rings parallel can be used as 1 channel N*10A current. For example: 2 rings 10A parallel could be used as 1 wires 20A

2) According to your own needs, 10A, 20A and 5A can be combined freely. Please contact customer service if you need over 2 channels Ethernet.

Product Quality Level Table

Products Level Code	Max Rotating Speed	Working Life	Contact Material
VC	150RPM	20 Million Revs	Precious Metal
VD	600RPM	80 Million Revs	Gold-plated

Lead Wires Color Code

Ring	1	2	3	4	5	6	7	8	9	10	11	12
Color	BLK	RED	YLW	GRN	BLU	WHT	BLK	RED	YLW	GRN	BLU	WHT

(6 wires for 1 group color, from 7-12, repeat the same color as 1...6, indicated with number code pipe)

Options for custom slip ring

Note: Below special demands can be customized. According, the delivery date will be extended 3 to 15 days; also the cost will be increased 30% to 50%. Most of our basic parts are standard and modular, which can save the cost and lead time.

- ① Bore diameter can be customized, cable exit way and cable length can be customized for both rotor and stator.
- ② Because of the structure limitation, length/height/OD can be customized on your request.
- ③ Support current or signal up to 200 rings.
- ④ Aviation plug, terminal and heat-shrink tube are optional.
- ⑤ Hybrid slip ring for Yaskawa/Panasonic/Siemens servo control signal, power line and encoder line.
- ⑥ Support mixed high speed data transmission (including Ethernet, USB, RS232, RS485, Profibus, CanBUS, CANOPEN, DeviceNET, CC-LINK, ProfiNET, EtherCAT, etc.)
- ⑦ Can combine temperature control signal with thermocouple signal.
- ⑧ Special environment can be customized, such as quakeproof, high temperature, etc.
- ⑨ Hybrid Pneumatic/hydraulic and electric slip ring can be mixed.
- ⑩ High temperature can up to 500 degrees.
- ⑪ High pressure can up to 110KV
- ⑫ Rotating speed can up to 10000RPM
- ⑬ Maximum current can up to 5000 amperes.
- ⑭ Military grade
- ⑮ Optional for underwater IP65, IP68.
- ⑯ Optional for stainless steel housing

Technical support: technical@moflon.com

ME2201 100M/1000M Ethernet Slip Rings

1 channel 1000M Ethernet+ 1~16 power and signal channel

ME2201, support 1 channel 1000M ethernet slip rings, with through bore size 20mm, overall diameter 69mm, are standard, off-the-shelf, Color-coded lead wires are used on both the stator and rotor for simplified electrical connections.

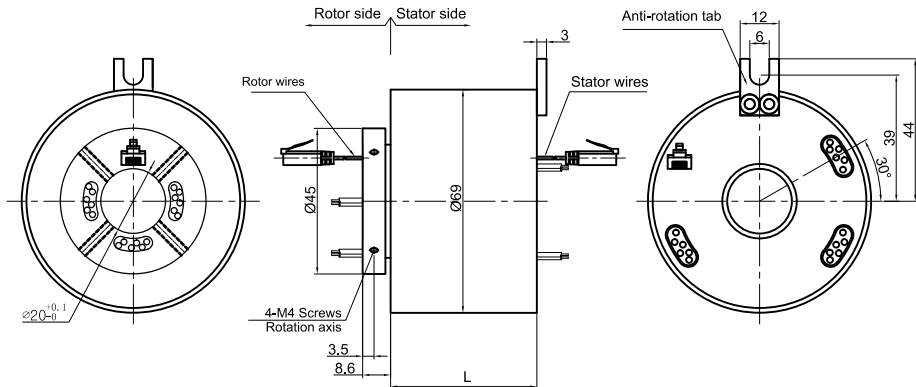

Part# Explanation

ME2201 - P 02 10- S 06 - VD		Products quality level
ME: Ethernet Slip Ring		VC common quality version
220: ID 20mm, OD 69		VD industrial quality version
1: 1 Channel 1000M Ethernet		Default =VC version
P: Power ring		06:0~2A/ring
0210: 2 rings , rated 0~2A/ring		S: Signal ring

Specifications

Ethernet Specification		
Parameter	Value	
1000M Ethernet	1 channel 1000M Ethernet	
Connector	RJ45	
Ber Error Rate	10E-11	
Electrical Data		
Parameter	Value	
	Power	Signal
Rated Voltage	0~440VAC/VDC	0~440VAC/VDC
Insulation Resistance	$\geq 1000\text{M}\Omega/500\text{VDC}$	$\geq 1000\text{M}\Omega/500\text{VDC}$
Lead Wires	AWG16#Teflon/PVC/Silicon	AWG22#Teflon
Lead Length	Standard 300mm(adjustable)	
Dielectric Strength	500VAC@50Hz , 60s	
Electrical Noise	<0.01 Ω	
Mechanical Data		
Parameter	Value	
Working Life	See Product Quality Level Table	
Rotating Speed	See Product Quality Level Table	
Working temperature	-30°C~80°C	
Operating Humidity	0~85% RH	
Contact Material	See Product Quality Level Table	
Housing Material	Aluminium Alloy	
Torque	0.1N.m ; +0.03N.m/6 rings	
Protection Grade	IP51	

Part# List

ME2201 Series Ethernet Slip Ring											
Part#	1000M Ethernet	10A	20A	Signal 5A	Length (mm)	Part#	1000M Ethernet	10A	20A	Signal 5A	Length (mm)
ME2201-S04	1	0	0	4	65.6	ME2201-P0410-S12	1	4	0	12	106.4
ME2201-P0410	1	4	0	0	65.6	ME2201-P0610-S10	1	6	0	10	106.4
ME2201-P0420	1	0	4	0	86	ME2201-P0810-S08	1	8	0	08	106.4
ME2201-S10	1	0	0	10	86	ME2201-P1010-S06	1	10	0	06	106.4
ME2201-P0210-S08	1	2	0	8	86	ME2201-P1210-S04	1	12	0	4	106.4
ME2201-P0410-S06	1	4	0	6	86	ME2201-S22	1	0	0	22	126.8
ME2201-P0610-S04	1	6	0	4	86	ME2201-S28	1	0	0	28	150.2
ME2201-S16	1	0	0	16	106.4	ME2201-S34	1	0	0	34	170.6
ME2201-P0210-S14	1	2	0	14	106.4						

Note: 1) N channels 10A rings parallel can be used as 1 channel N*10A current. For example: 2 rings 10A parallel could be used as 1 wires 20A

2) According to your own needs, 10A, 20A and 5A can be combined freely. Please contact customer service if you need over 2 channels Ethernet.

Product Quality Level Table

Products Level Code	Max Rotating Speed	Working Life	Contact Material
VC	150RPM	20 Million Revs	Precious Metal
VD	600RPM	80 Million Revs	Gold-plated

Lead Wires Color Code

Ring	1	2	3	4	5	6	7	8	9	10	11	12
Color	BLK	RED	YLW	GRN	BLU	WHT	BLK	RED	YLW	GRN	BLU	WHT

(6 wires for 1 group color, from 7-12, repeat the same color as 1...6, indicated with number code pipe)

Options for custom slip ring

Note: Below special demands can be customized. According, the delivery date will be extended 3 to 15 days; also the cost will be increased 30% to 50%. Most of our basic parts are standard and modular, which can save the cost and lead time.

- ① Bore diameter can be customized, cable exit way and cable length can be customized for both rotor and stator.
- ② Because of the structure limitation, length/height/OD can be customized on your request.
- ③ Support current or signal up to 200 rings.
- ④ Aviation plug, terminal and heat-shrink tube are optional.
- ⑤ Hybrid slip ring for Yaskawa/Panasonic/Siemens servo control signal, power line and encoder line.
- ⑥ Support mixed high speed data transmission (including Ethernet, USB, RS232, RS485, Profibus, CanBUS, CANOPEN, DeviceNET, CC-LINK, ProfiNET, EtherCAT, etc.)
- ⑦ Can combine temperature control signal with thermocouple signal.
- ⑧ Special environment can be customized, such as quakeproof, high temperature, etc.
- ⑨ Hybrid Pneumatic/hydraulic and electric slip ring can be mixed.
- ⑩ High temperature can up to 500 degrees.
- ⑪ High pressure can up to 110KV
- ⑫ Rotating speed can up to 10000RPM
- ⑬ Maximum current can up to 5000 amperes.
- ⑭ Military grade
- ⑮ Optional for underwater IP65, IP68.
- ⑯ Optional for stainless steel housing

Technical support: technical@moflon.com

ME2202 100M/1000M Ethernet Slip Rings

2 channels 1000M Ethernet+ 1~16 power and signal channel

ME2202, support 2 channels 1000M ethernet slip rings, with through bore size 20mm, overall diameter 69mm, are standard, off-the-shelf, Color-coded lead wires are used on both the stator and rotor for simplified electrical connections.

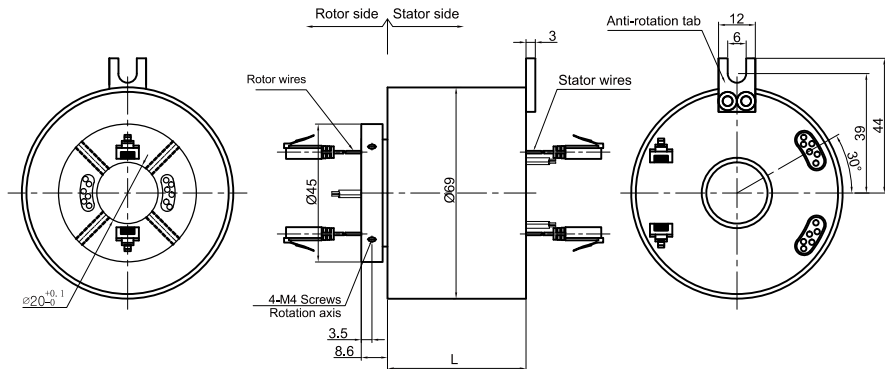

Part# Explanation

ME: Ethernet Slip Ring	220: ID 20mm, OD 69	2: 2 channels 1000M Ethernet	P: Power ring	0210: 2 rings , rated 0~2A/ring	S 06	VD	Products quality level VC common quality version VD industrial quality version Default =VC version
					06:0~2A/ring		S: Signal ring

Specifications

Ethernet Specification			
Parameter	Value		
1000M Ethernet	2 channels 1000M Ethernet		
Connector	RJ45		
Ber Error Rate	10E-11		
Electrical Data			
Parameter	Value		
	Power	Signal	
Rated Voltage	0~440VAC/VDC	0~440VAC/VDC	
Insulation Resistance	$\geq 1000\text{M}\Omega/500\text{VDC}$	$\geq 1000\text{M}\Omega/500\text{VDC}$	
Lead Wires	AWG16#Teflon/PVC/Silicon	AWG22#Teflon	
Lead Length	Standard 300mm(adjustable)		
Dielectric Strength	500VAC@50Hz , 60s		
Electrical Noise	<0.01 Ω		
Mechanical Data			
Parameter	Value		
Working Life	See Product Quality Level Table		
Rotating Speed	See Product Quality Level Table		
Working temperature	-30°C~80°C		
Operating Humidity	0~85% RH		
Contact Material	See Product Quality Level Table		
Housing Material	Aluminium Alloy		
Torque	0.1N.m ; +0.03N.m/6 rings		
Protection Grade	IP51		

Part# List

ME2202 Series Ethernet Slip Ring											
Part#	1000M Ethernet	10A	20A	Signal 5A	Length (mm)	Part#	1000M Ethernet	10A	20A	Signal 5A	Length (mm)
ME2202-S02	2	0	0	2	86	ME2202-S14	2	0	0	14	126.8
ME2202-P0210	2	2	0	0	86	ME2202-P0410-S10	2	4	0	10	126.8
ME2202-P0420	2	0	4	0	106.4	ME2202-P0610-S08	2	6	0	8	126.8
ME2202-S08	2	0	0	8	106.4	ME2202-P1010-S04	2	10	0	04	126.8
ME2202-P0810	2	8	0	0	106.4	ME2202-S20	2	0	0	20	150.2
ME2202-P0210-S06	2	2	0	6	106.4	ME2202-S26	2	0	0	26	170.6
ME2202-P0410-S04	2	4	0	4	106.4	ME2202-S32	2	0	0	32	191

Note: 1) N channels 10A rings parallel can be used as 1 channel N*10A current. For example: 2 rings 10A parallel could be used as 1 wires 20A

2) According to your own needs, 10A, 20A and 5A can be combined freely. Please contact customer service if you need over 2 channels Ethernet.

Product Quality Level Table

Products Level Code	Max Rotating Speed	Working Life	Contact Material
VC	150RPM	20 Million Revs	Precious Metal
VD	600RPM	80 Million Revs	Gold-plated

Lead Wires Color Code

Ring	1	2	3	4	5	6	7	8	9	10	11	12
Color	BLK	RED	YLW	GRN	BLU	WHT	BLK	RED	YLW	GRN	BLU	WHT

(6 wires for 1 group color, from 7-12, repeat the same color as 1...6, indicated with number code pipe)

Options for custom slip ring

Note: Below special demands can be customized. According, the delivery date will be extended 3 to 15 days; also the cost will be increased 30% to 50%. Most of our basic parts are standard and modular, which can save the cost and lead time.

- ① Bore diameter can be customized, cable exit way and cable length can be customized for both rotor and stator.
- ② Because of the structure limitation, length/height/OD can be customized on your request.
- ③ Support current or signal up to 200 rings.
- ④ Aviation plug, terminal and heat-shrink tube are optional.
- ⑤ Hybrid slip ring for Yaskawa/Panasonic/Siemens servo control signal, power line and encoder line.
- ⑥ Support mixed high speed data transmission (including Ethernet, USB, RS232, RS485, Profibus, CanBUS, CANOPEN, DeviceNET, CC-LINK, ProfiNET, EtherCAT, etc.)
- ⑦ Can combine temperature control signal with thermocouple signal.
- ⑧ Special environment can be customized, such as quakeproof, high temperature, etc.
- ⑨ Hybrid Pneumatic/hydraulic and electric slip ring can be mixed.
- ⑩ High temperature can up to 500 degrees.
- ⑪ High pressure can up to 110KV
- ⑫ Rotating speed can up to 10000RPM
- ⑬ Maximum current can up to 5000 amperes.
- ⑭ Military grade
- ⑮ Optional for underwater IP65, IP68.
- ⑯ Optional for stainless steel housing

Technical support: technical@moflon.com

ME2251 100M/1000M Ethernet Slip Rings

1 channel 1000M Ethernet+ 1~16 power and signal channel

ME2251, support 1 channel 1000M ethernet slip rings, with through bore size 25.4mm, overall diameter 86mm, are standard, off-the-shelf, Color-coded lead wires are used on both the stator and rotor for simplified electrical connections.

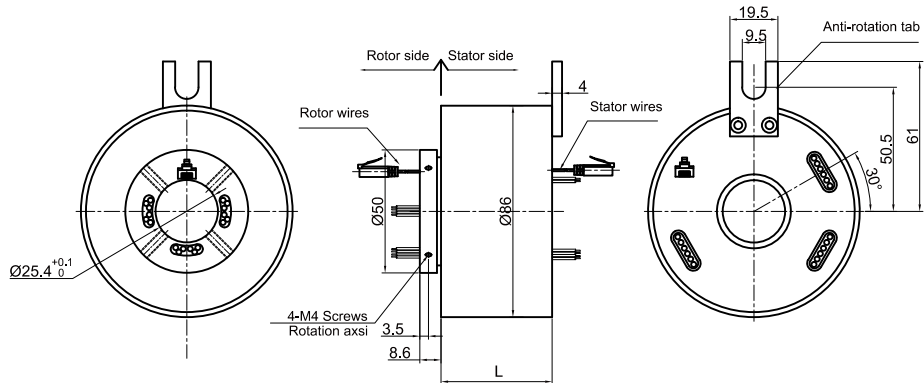
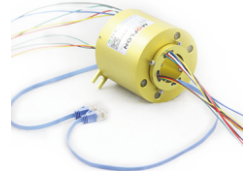

Part# Explanation

ME: Ethernet Slip Ring	ME2251	-	P	02	10	-	S	06	-	VD	Products quality level
225: ID 25.4mm, OD 86											VC common quality version
1: 1 channel 1000M Ethernet											VD industrial quality version
P: Power ring											Default =VC version
0210: 2 rings , rated 0~2A/ring											06:0~2A/ring
											S: Signal ring

Specifications

Ethernet Specification		
Parameter	Value	
1000M Ethernet	1 channel 1000M Ethernet	
Connector	RJ45	
Ber Error Rate	10E-11	
Electrical Data		
Parameter	Value	
	Power	Signal
Rated Voltage	0~440VAC/VDC	0~440VAC/VDC
Insulation Resistance	≥1000MΩ/500VDC	≥1000MΩ/500VDC
Lead Wires	AWG16#Teflon/PVC/Silicon	AWG22#Teflon
Lead Length	Standard 300mm(adjustable)	
Dielectric Strength	500VAC@50Hz , 60s	
Electrical Noise	<0.01Ω	
Mechanical Data		
Parameter	Value	
Working Life	See Product Quality Level Table	
Rotating Speed	See Product Quality Level Table	
Working temperature	-30°C~80°C	
Operating Humidity	0~85% RH	
Contact Material	See Product Quality Level Table	
Housing Material	Aluminium Alloy	
Torque	0.1N.m ; +0.03N.m/6 rings	
Protection Grade	IP51	

Part# List

ME2251 Series Ethernet Slip Ring											
Part#	1000M Ethernet	10A	20A	Signal 5A	Length (mm)	Part#	1000M Ethernet	10A	20A	Signal 5A	Length (mm)
ME2251-S04	1	0	0	4	65.6	ME2251-P0810-S08	1	8	0	8	106.4
ME2251-P0410	1	4	0	0	65.6	ME2251-P1010-S06	1	10	0	6	106.4
ME2251-P0420	1	0	4	0	86	ME2251-S22	1	0	0	22	126.8
ME2251-S10	1	0	0	10	86	ME2251-P0410-S18	1	4	0	18	126.8
ME2251-P0210-S08	1	2	0	8	86	ME2251-P2210	1	22	0	0	126.8
ME2251-P0410-S06	1	4	0	6	86	ME2251-S28	1	0	0	28	147.2
ME2251-P0610-S04	1	6	0	4	86	ME2251-P0610-S22	1	6	0	22	147.2
ME2251-S16	1	0	0	16	106.4	ME2251-P0610-S34	1	6	0	34	191
ME2251-P1610	1	16	0	0	106.4	ME2251-S40	1	0	0	40	191
ME2251-P0410-S12	1	4	0	12	106.4	ME2251-P0610-S40	1	6	0	40	211.4
ME2251-P0610-S10	1	6	0	10	106.4	ME2251-S46	1	0	0	46	211.4

Note: 1) N channels 10A rings parallel can be used as 1 channel N*10A current. For example: 2 rings 10A parallel could be used as 1 wires 20A

2) According to your own needs, 10A, 20A and 5A can be combined freely. Please contact customer service if you need over 2 channels Ethernet.

Product Quality Level Table

Products Level Code	Max Rotating Speed	Working Life	Contact Material
VC	150RPM	20 Million Revs	Precious Metal
VD	600RPM	80 Million Revs	Gold-plated

Lead Wires Color Code

Ring	1	2	3	4	5	6	7	8	9	10	11	12
Color	BLK	RED	YLW	GRN	BLU	WHT	BLK	RED	YLW	GRN	BLU	WHT

(6 wires for 1 group color, from 7-12, repeat the same color as 1...6, indicated with number code pipe)

Options for custom slip ring

Note: Below special demands can be customized. According, the delivery date will be extended 3 to 15 days; also the cost will be increased 30% to 50%. Most of our basic parts are standard and modular, which can save the cost and lead time.

- ① Bore diameter can be customized, cable exit way and cable length can be customized for both rotor and stator.
- ② Because of the structure limitation, length/height/OD can be customized on your request.
- ③ Support current or signal up to 200 rings.
- ④ Aviation plug, terminal and heat-shrink tube are optional.
- ⑤ Hybrid slip ring for Yaskawa/Panasonic/Siemens servo control signal, power line and encoder line.
- ⑥ Support mixed high speed data transmission (including Ethernet, USB, RS232, RS485, Profibus, CanBUS, CANOPEN, DeviceNET, CC-LINK, ProfiNET, EtherCAT, etc.)
- ⑦ Can combine temperature control signal with thermocouple signal.
- ⑧ Special environment can be customized, such as quakeproof, high temperature, etc.
- ⑨ Hybrid Pneumatic/hydraulic and electric slip ring can be mixed.
- ⑩ High temperature can up to 500 degrees.
- ⑪ High pressure can up to 110KV
- ⑫ Rotating speed can up to 10000RPM
- ⑬ Maximum current can up to 5000 amperes.
- ⑭ Military grade
- ⑮ Optional for underwater IP65, IP68.
- ⑯ Optional for stainless steel housing

Technical support: technical@moflon.com

ME2252 100M/1000M Ethernet Slip Rings

2 channels 1000M Ethernet+ 1~16 power and signal channel

ME2252, support 2 channels 1000M ethernet slip rings, with through bore size 25.4mm, overall diameter 86mm, are standard, off-the-shelf, Color-coded lead wires are used on both the stator and rotor for simplified electrical connections.

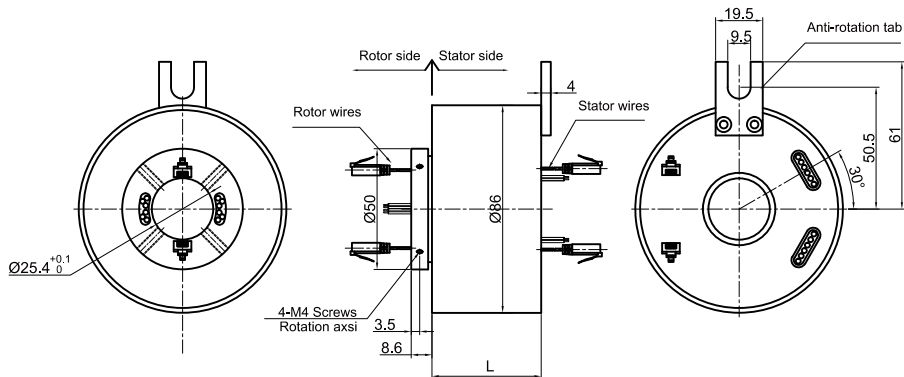

Part# Explanation



Specifications

Ethernet Specification		
Parameter	Value	
1000M Ethernet	2 channel 1000M Ethernet	
Connector	RJ45	
Ber Error Rate	10E-11	
Electrical Data		
Parameter	Value	
	Power	Signal
Rated Voltage	0~440VAC/VDC	0~440VAC/VDC
Insulation Resistance	≥1000MΩ/500VDC	≥1000MΩ/500VDC
Lead Wires	AWG16#Teflon	AWG22#Teflon
Lead Length	Standard 300mm(adjustable)	
Dielectric Strength	500VAC@50Hz , 60s	
Electrical Noise	<0.01Ω	
Mechanical Data		
Parameter	Value	
Working Life	See Product Quality Level Table	
Rotating Speed	See Product Quality Level Table	
Working Temperature	-30°C~80°C	
Operating Humidity	0~85% RH	
Contact Material	See Product Quality Level Table	
Housing Material	Aluminium Alloy	
Torque	0.1N.m ; +0.03N.m/6 rings	
Protection Grade	IP51	

Part# List

ME2252-2 Series Ethernet Slip Ring											
Part#	1000M Ethernet	10A	20A	Signal 5A	Length (mm)	Part#	1000M Ethernet	10A	20A	Signal 5A	Length (mm)
ME2252-S02	2	0	0	2	86	ME2252-P1010-S04	2	10	0	4	126.8
ME2252-P0210	2	2	0	0	86	ME2252-P1410	2	14	0	0	126.8
ME2252-S08	2	0	0	8	106.4	ME2252-S20	2	0	0	20	147.2
ME2252-P0810	2	8	0	0	106.4	ME2252-P0410-S16	2	4	0	16	147.2
ME2252-P0420	2	0	4	0	106.4	ME2252-P1010-S10	2	10	0	10	147.2
ME2252-P0410-S04	2	4	0	4	106.4	ME2252-P2010	2	20	0	0	147.2
ME2252-S14	2	0	0	14	126.8	ME2252-P0610-S26	2	6	0	26	191
ME2252-P0410-S10	2	4	0	10	126.8	ME2252-S32	2	0	0	32	191
ME2252-P0610-S08	2	6	0	8	126.8	ME2252-P0610-S32	2	6	0	32	211.4
ME2252-P0810-S06	2	8	0	6	126.8	ME2252-S38	2	0	0	38	211.4

Note: 1) N channels 10A rings parallel can be used as 1 channel N*10A current. For example: 2 rings 10A parallel could be used as 1 wires 20A

2) According to your own needs, 10A, 20A and 5A can be combined freely. Please contact customer service if you need over 2 channels Ethernet.

Product Quality Level Table

Products Level Code	Max Rotating Speed	Working Life	Contact Material
VC	150RPM	20 Million Revs	Precious Metal
VD	600RPM	80 Million Revs	Gold-plated

Lead Wires Color Code

Ring	1	2	3	4	5	6	7	8	9	10	11	12
Color	BLK	RED	YLW	GRN	BLU	WHT	BLK	RED	YLW	GRN	BLU	WHT

(6 wires for 1 group color, from 7-12, repeat the same color as 1...6, indicated with number code pipe)

Options for custom slip ring

Note: Below special demands can be customized. According, the delivery date will be extended 3 to 15 days; also the cost will be increased 30% to 50%. Most of our basic parts are standard and modular, which can save the cost and lead time.

- ① Bore diameter can be customized, cable exit way and cable length can be customized for both rotor and stator.
- ② Because of the structure limitation, length/height/OD can be customized on your request.
- ③ Support current or signal up to 200 rings.
- ④ Aviation plug, terminal and heat-shrink tube are optional.
- ⑤ Hybrid slip ring for Yaskawa/Panasonic/Siemens servo control signal, power line and encoder line.
- ⑥ Support mixed high speed data transmission (including Ethernet, USB, RS232, RS485, Profibus, CanBUS, CANOPEN, DeviceNET, CC-LINK, ProfiNET, EtherCAT, etc.)
- ⑦ Can combine temperature control signal with thermocouple signal.
- ⑧ Special environment can be customized, such as quakeproof, high temperature, etc.
- ⑨ Hybrid Pneumatic/hydraulic and electric slip ring can be mixed.
- ⑩ High temperature can up to 500 degrees.
- ⑪ High pressure can up to 110KV
- ⑫ Rotating speed can up to 10000RPM
- ⑬ Maximum current can up to 5000 amperes.
- ⑭ Military grade
- ⑮ Optional for underwater IP65, IP68.
- ⑯ Optional for stainless steel housing

Technical support: technical@moflon.com

ME2381 100M/1000M Ethernet Slip Rings

1 channel 1000M Ethernet+ 1~16 power and signal channel

ME2381, support 1 channel 1000M ethernet slip rings, with through bore size 38.1mm, overall diameter 99mm, are standard, off-the-shelf, Color-coded lead wires are used on both the stator and rotor for simplified electrical connections.

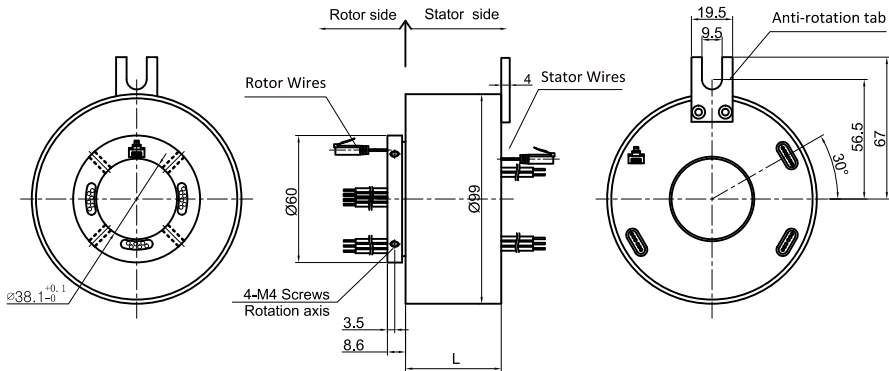
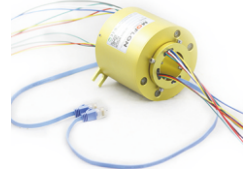

Part# Explanation

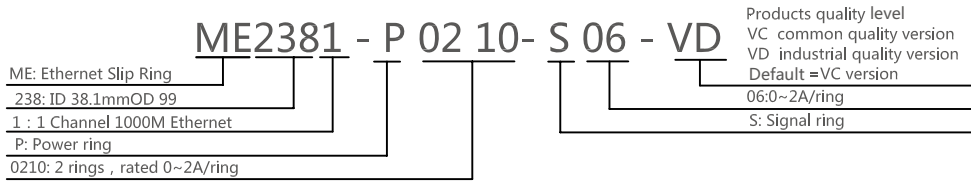

Specifications

Ethernet Specification	
Parameter	Value
1000M Ethernet	1 channel 1000M Ethernet
Connector	RJ45
Ber Error Rate	10E-11
Electrical Data	
Parameter	Value
	Power
Rated Voltage	0~440VAC/VDC
Insulation Resistance	≥1000MΩ/500VDC
Lead Wires	AWG16#Teflon
Lead Length	Standard 300mm(adjustable)
Dielectric Strength	500VAC@50Hz , 60s
Electrical Noise	<0.01Ω
	Signal
	0~440VAC/VDC
	≥1000MΩ/500VDC
	AWG22#Teflon
Mechanical Data	
Parameter	Value
Working Life	See Product Quality Level Table
Rotating Speed	See Product Quality Level Table
Working Temperature	-30°C~80°C
Operating Humidity	0~85% RH
Contact Material	See Product Quality Level Table
Housing Material	Aluminium Alloy
Torque	0.1N.m ; +0.03N.m/6 rings
Protection Grade	IP51

Part# List

ME2381 Series Ethernet Slip Ring											
Part#	1000M Ethernet	10A	20A	Signal 5A	Length (mm)	Part#	1000M Ethernet	10A	20A	Signal 5A	Length (mm)
ME2381-S04	1	0	0	4	65.6	ME2381-P0810-S08	1	8	0	8	106.4
ME2381-P0410	1	4	0	0	65.6	ME2381-P1010-S06	1	10	0	6	106.4
ME2381-P0420	1	0	4	0	86	ME2381-S22	1	0	0	22	126.8
ME2381-S10	1	0	0	10	86	ME2381-P0410-S18	1	4	0	18	126.8
ME2381-P0210-S08	1	2	0	8	86	ME2381-P2210	1	22	0	0	126.8
ME2381-P0410-S06	1	4	0	6	86	ME2381-S28	1	6	0	28	147.2
ME2381-P0610-S04	1	6	0	4	86	ME2381-P0610-S22	1	6	0	22	147.2
ME2381-S16	1	0	0	16	106.4	ME2381-P0610-S34	1	6	0	34	191
ME2381-P1610	1	16	0	0	106.4	ME2381-S40	1	0	0	40	191
ME2381-P0410-S12	1	4	0	12	106.4	ME2381-P0610-S40	1	6	0	40	211.4
ME2381-P0610-S10	1	6	0	10	106.4	ME2381-S46	1	0	0	46	211.4

Note: 1) N channels 10A rings parallel can be used as 1 channel N*10A current. For example: 2 rings 10A parallel could be used as 1 wires 20A

2) According to your own needs, 10A, 20A and 5A can be combined freely. Please contact customer service if you need over 2 channels Ethernet.

Product Quality Level Table

Products Level Code	Max Rotating Speed	Working Life	Contact Material
VC	150RPM	20 Million Revs	Precious Metal
VD	600RPM	80 Million Revs	Gold-plated

Lead Wires Color Code

Ring	1	2	3	4	5	6	7	8	9	10	11	12
Color	BLK	RED	YLW	GRN	BLU	WHT	BLK	RED	YLW	GRN	BLU	WHT

(6 wires for 1 group color, from 7-12, repeat the same color as 1...6, indicated with number code pipe)

Options for custom slip ring

Note: Below special demands can be customized. According, the delivery date will be extended 3 to 15 days; also the cost will be increased 30% to 50%. Most of our basic parts are standard and modular, which can save the cost and lead time.

- ① Bore diameter can be customized, cable exit way and cable length can be customized for both rotor and stator.
- ② Because of the structure limitation, length/height/OD can be customized on your request.
- ③ Support current or signal up to 200 rings.
- ④ Aviation plug, terminal and heat-shrink tube are optional.
- ⑤ Hybrid slip ring for Yaskawa/Panasonic/Siemens servo control signal, power line and encoder line.
- ⑥ Support mixed high speed data transmission (including Ethernet, USB, RS232, RS485, Profibus, CanBUS, CANOPEN, DeviceNET, CC-LINK, ProfiNET, EtherCAT, etc.)
- ⑦ Can combine temperature control signal with thermocouple signal.
- ⑧ Special environment can be customized, such as quakeproof, high temperature, etc.
- ⑨ Hybrid Pneumatic/hydraulic and electric slip ring can be mixed.
- ⑩ High temperature can up to 500 degrees.
- ⑪ High pressure can up to 110KV
- ⑫ Rotating speed can up to 10000RPM
- ⑬ Maximum current can up to 5000 amperes.
- ⑭ Military grade
- ⑮ Optional for underwater IP65, IP68.
- ⑯ Optional for stainless steel housing

Technical support: technical@moflon.com

ME2382 100M/1000M Ethernet Slip Rings

2 channels 1000M Ethernet+ 1~16 power and signal channel

ME2382, support 2 channels 1000M ethernet slip rings, with through bore size 38.1mm, overall diameter 99mm, are standard, off-the-shelf, Color-coded lead wires are used on both the stator and rotor for simplified electrical connections.

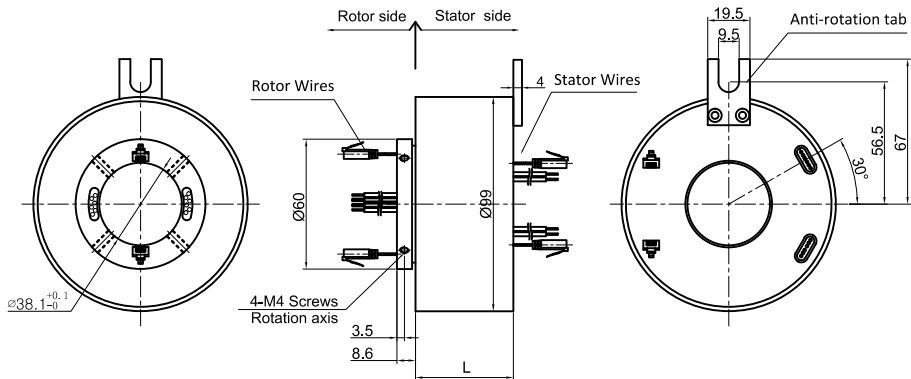

Part# Explanation

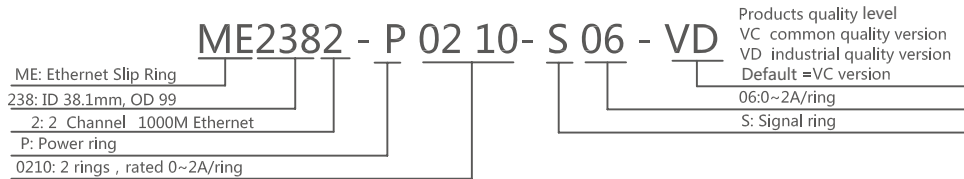

Specifications

Ethernet Specification			
Parameter	Value		
1000M Ethernet	2 channels 1000M Ethernet		
Connector	RJ45		
Ber Error Rate	10E-11		
Electrical Data			
Parameter	Value		
	Power	Signal	
Rated Voltage	0~440VAC/VDC	0~440VAC/VDC	
Insulation Resistance	≥1000MΩ/500VDC	≥1000MΩ/500VDC	
Lead Wires	AWG16#Teflon	AWG22#Teflon	
Lead Length	Standard 300mm(adjustable)		
Dielectric Strength	500VAC@50Hz, 60s		
Electrical Noise	<0.01Ω		
Mechanical Data			
Parameter	Value		
Working Life	See Product Quality Level Table		
Rotating Speed	See Product Quality Level Table		
Working Temperature	-30°C~80°C		
Operating Humidity	0~85% RH		
Contact Material	See Product Quality Level Table		
Housing Material	Aluminium Alloy		
Torque	0.1N.m ; +0.03N.m/6 rings		
Protection Grade	IP51		

Part# List

ME2382 Series Ethernet Slip Ring											
Part#	1000M Ethernet	10A	20A	Signal 5A	Length (mm)	Part#	1000M Ethernet	10A	20A	Signal 5A	Length (mm)
ME2382-S02	2	0	0	2	86	ME2382-P1010-S04	2	10	0	4	126.8
ME2382-P0210	2	2	0	0	86	ME2382-P1410	2	14	0	0	126.8
ME2382-S08	2	0	0	8	106.4	ME2382-S20	2	0	0	20	147.2
ME2382-P0810	2	8	0	0	106.4	ME2382-P0410-S16	2	4	0	16	147.2
ME2382-P0420	2	0	4	0	106.4	ME2382-P1010-S10	2	10	0	10	147.2
ME2382-P0410-S04	2	4	0	4	106.4	ME2382-P2010	2	20	0	0	147.2
ME2382-S14	2	0	0	14	126.8	ME2382-P0610-S26	2	6	0	26	191
ME2382-P0410-S10	2	4	0	10	126.8	ME2382-S32	2	0	0	32	191
ME2382-P0610-S08	2	6	0	8	126.8	ME2382-P0610-S32	2	6	0	32	211.4
ME2382-P0810-S06	2	8	0	6	126.8	ME2382-S38	2	0	0	38	211.4

Note: 1) N channels 10A rings parallel can be used as 1 channel N*10A current. For example: 2 rings 10A parallel could be used as 1 wires 20A

2) According to your own needs, 10A, 20A and 5A can be combined freely. Please contact customer service if you need over 2 channels Ethernet.

Product Quality Level Table

Products Level Code	Max Rotating Speed	Working Life	Contact Material
VC	150RPM	20 Million Revs	Precious Metal
VD	600RPM	80 Million Revs	Gold-plated

Lead Wires Color Code

Ring	1	2	3	4	5	6	7	8	9	10	11	12
Color	BLK	RED	YLW	GRN	BLU	WHT	BLK	RED	YLW	GRN	BLU	WHT

(6 wires for 1 group color, from 7-12, repeat the same color as 1...6, indicated with number code pipe)

Options for custom slip ring

Note: Below special demands can be customized. According, the delivery date will be extended 3 to 15 days; also the cost will be increased 30% to 50%. Most of our basic parts are standard and modular, which can save the cost and lead time.

- ① Bore diameter can be customized, cable exit way and cable length can be customized for both rotor and stator.
- ② Because of the structure limitation, length/height/OD can be customized on your request.
- ③ Support current or signal up to 200 rings.
- ④ Aviation plug, terminal and heat-shrink tube are optional.
- ⑤ Hybrid slip ring for Yaskawa/Panasonic/Siemens servo control signal, power line and encoder line.
- ⑥ Support mixed high speed data transmission (including Ethernet, USB, RS232, RS485, Profibus, CanBUS, CANOPEN, DeviceNET, CC-LINK, ProfiNET, EtherCAT, etc.)
- ⑦ Can combine temperature control signal with thermocouple signal.
- ⑧ Special environment can be customized, such as quakeproof, high temperature, etc.
- ⑨ Hybrid Pneumatic/hydraulic and electric slip ring can be mixed.
- ⑩ High temperature can up to 500 degrees.
- ⑪ High pressure can up to 110KV
- ⑫ Rotating speed can up to 10000RPM
- ⑬ Maximum current can up to 5000 amperes.
- ⑭ Military grade
- ⑮ Optional for underwater IP65, IP68.
- ⑯ Optional for stainless steel housing

Technical support: technical@moflon.com

ME2501 100M/1000M Ethernet Slip Rings

1 channel 1000M Ethernet+ 1~16 power and signal channel

ME2501, support 1 channel 1000M ethernet slip rings, with through bore size 50mm, overall diameter 119mm, are standard, off-the-shelf, Color-coded lead wires are used on both the stator and rotor for simplified electrical connections.

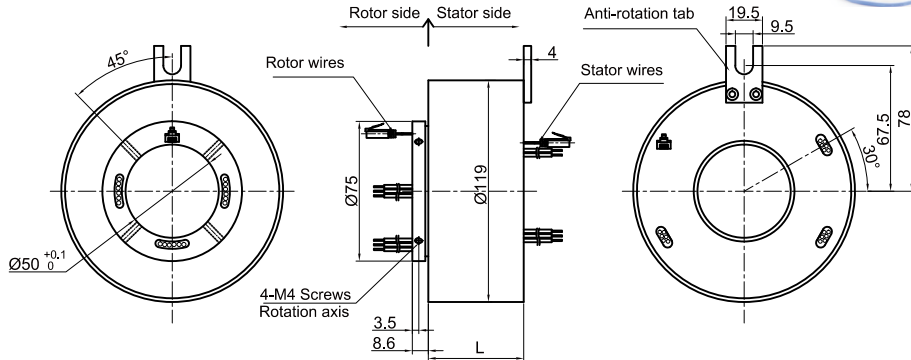

Part# Explanation

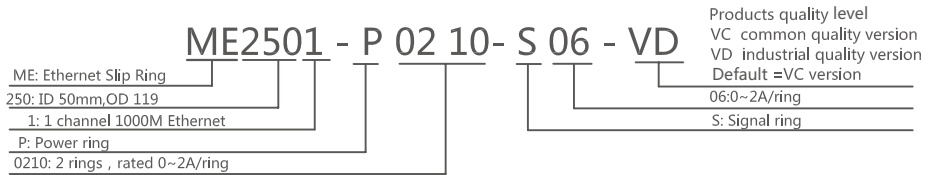

Specifications

Ethernet Specification		
Parameter	Value	
1000M Ethernet	1 channel 1000M Ethernet	
Connector	RJ45	
Ber Error Rate	10E-11	
Electrical Data		
Parameter	Value	
	Power	Signal
Rated Voltage	0~440VAC/VDC	0~440VAC/VDC
Insulation Resistance	≥1000MΩ/500VDC	≥1000MΩ/500VDC
Lead Wires	AWG16#Teflon	AWG22#Teflon
Lead Length	Standard 300mm(adjustable)	
Dielectric Strength	500VAC@50Hz , 60s	
Electrical Noise	<0.01Ω	
Mechanical Data		
Parameter	Value	
Working Life	See Product Quality Level Table	
Rotating Speed	See Product Quality Level Table	
Working Temperature	-30°C~80°C	
Operating Humidity	0~85% RH	
Contact Material	See Product Quality Level Table	
Housing Material	Aluminium Alloy	
Torque	0.1N.m ; +0.03N.m/6 rings	
Protection Grade	IP51	

Part# List

ME2501 Series Ethernet Slip Ring											
Part#	1000M Ethernet	10A	20A	Signal 5A	Length (mm)	Part#	1000M Ethernet	10A	20A	Signal 5A	Length (mm)
ME2501-S04	1	0	0	4	74	ME2501-P1010-S06	1	10	0	6	120
ME2501-P0410	1	4	0	0	74	ME2501-S22	1	0	0	22	142.4
ME2501-P0420	1	0	4	0	96.8	ME2501-P0410-S18	1	4	0	18	142.4
ME2501-S10	1	0	0	10	96.8	ME2501-P1010-S12	1	10	0	12	142.4
ME2501-P0210-S08	1	2	0	8	96.8	ME2501-P2210	1	22	0	0	142.4
ME2501-P0410-S06	1	4	0	6	96.8	ME2501-P0610-S22	1	6	0	22	165.2
ME2501-P0610-S04	1	6	0	4	96.8	ME2501-P0610-S34	1	6	0	34	214.8
ME2501-P1010	1	10	0	0	96.8	ME2501-P1210-S28	1	12	0	28	214.8
ME2501-S16	1	0	0	16	120	ME2501-S40	1	0	0	40	214.8
ME2501-P1610	1	16	0	0	120	ME2501-P0610-S40	1	6	0	40	237.6
ME2501-P0410-S12	1	4	0	12	120	ME2501-S46	1	0	0	46	237.6
ME2501-P0810-S08	1	8	0	8	120						

Note: 1) N channels 10A rings parallel can be used as 1 channel N*10A current. For example: 2 rings 10A parallel could be used as 1 wires 20A

2) According to your own needs, 10A, 20A and 5A can be combined freely. Please contact customer service if you need over 2 channels Ethernet.

Product Quality Level Table

Products Level Code	Max Rotating Speed	Working Life	Contact Material
VC	150RPM	20 Million Revs	Precious Metal
VD	600RPM	80 Million Revs	Gold-plated

Lead Wires Color Code

Ring	1	2	3	4	5	6	7	8	9	10	11	12
Color	BLK	RED	YLW	GRN	BLU	WHT	BLK	RED	YLW	GRN	BLU	WHT

(6 wires for 1 group color, from 7-12, repeat the same color as 1...6, indicated with number code pipe)

Options for custom slip ring

Note: Below special demands can be customized. According, the delivery date will be extended 3 to 15 days; also the cost will be increased 30% to 50%. Most of our basic parts are standard and modular, which can save the cost and lead time.

- ① Bore diameter can be customized, cable exit way and cable length can be customized for both rotor and stator.
 - ② Because of the structure limitation, length/height/OD can be customized on your request.
 - ③ Support current or signal up to 200 rings.
 - ④ Aviation plug, terminal and heat-shrink tube are optional.
 - ⑤ Hybrid slip ring for Yaskawa/Panasonic/Siemens servo control signal, power line and encoder line.
 - ⑥ Support mixed high speed data transmission (including Ethernet, USB, RS232, RS485, Profibus, CanBUS, CANOPEN, DeviceNET, CC-LINK, ProfiNET, EtherCAT, etc.)
 - ⑦ Can combine temperature control signal with thermocouple signal.
 - ⑧ Special environment can be customized, such as quakeproof, high temperature, etc.
 - ⑨ Hybrid Pneumatic/hydraulic and electric slip ring can be mixed.
 - ⑩ High temperature can up to 500 degrees.
 - ⑪ High pressure can up to 110KV
 - ⑫ Rotating speed can up to 10000RPM
 - ⑬ Maximum current can up to 5000 amperes.
 - ⑭ Military grade
 - ⑮ Optional for underwater IP65, IP68.
 - ⑯ Optional for stainless steel housing
- Technical support: technical@moflon.com

ME2502 100M/1000M Ethernet Slip Rings

2 channels 1000M Ethernet+ 1~16 power and signal channel

ME2502, support 2 channels 1000M ethernet slip rings, with through bore size 50mm, overall diameter 119mm, are standard, off-the-shelf, Color-coded lead wires are used on both the stator and rotor for simplified electrical connections.

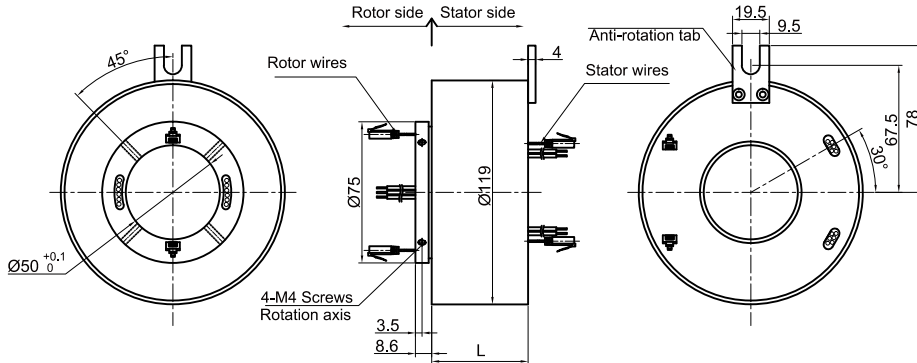

Part# Explanation

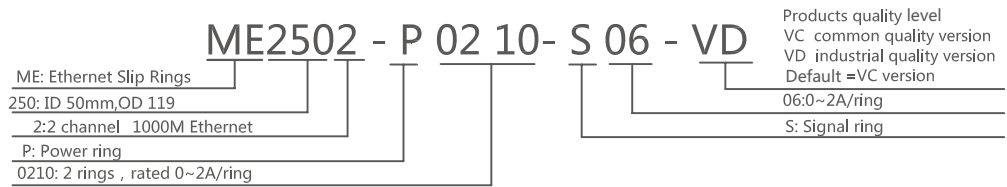

Specifications

Ethernet Specification	
Parameter	Value
1000M Ethernet	2 channel 1000M Ethernet
Connector	RJ45
Ber Error Rate	10E-11
Electrical Data	
Parameter	Value
	Power
Rated Voltage	0~440VAC/VDC
Insulation Resistance	≥1000MΩ/500VDC
Lead Wires	AWG16#Teflon/PVC/Silicon
Lead Length	Standard 300mm(adjustable)
Dielectric Strength	500VAC@50Hz, 60s
Electrical Noise	<0.01Ω
	Signal
	0~440VAC/VDC
	≥1000MΩ/500VDC
	AWG22#Teflon
Mechanical Data	
Parameter	Value
Working Life	See Product Quality Level Table
Rotating Speed	See Product Quality Level Table
Working Temperature	-30°C~80°C
Operating Humidity	0~85% RH
Contact Material	See Product Quality Level Table
Housing Material	Aluminium Alloy
Torque	0.1N.m ; +0.03N.m/6 rings
Protection Grade	IP51

Part# List

ME2502 Series Ethernet Slip Ring											
Part#	1000M Ethernet	10A	20A	Signal 5A	Length (mm)	Part#	1000M Ethernet	10A	20A	Signal 5A	Length (mm)
ME2502-S02	2	0	0	2	96.8	ME2502-S20	2	0	0	20	165.2
ME2502-P0210	2	2	0	0	96.8	ME2502-P0410-S16	2	4	0	16	165.2
ME2502-S08	2	0	0	8	120	ME2502-P1010-S10	2	10	0	10	165.2
ME2502-P0810	2	8	0	0	120	ME2502-P1410-S06	2	14	0	6	165.2
ME2502-P0420	2	0	4	0	120	ME2502-P2010	2	20	0	0	165.2
ME2502-P0410-S04	2	4	0	4	120	ME2502-P0610-S26	2	6	0	26	214.8
ME2502-S14	2	0	0	14	142.4	ME2502-P1210-S20	2	12	0	20	214.8
ME2502-P0610-S08	2	6	0	8	142.4	ME2502-S32	2	0	0	32	214.8
ME2502-P0410-S10	2	4	0	10	142.4	ME2502-P0610-S32	2	6	0	32	237.6
ME2502-P0810-S06	2	8	0	6	142.4	ME2501-P1210-S26	2	12	0	26	237.6
ME2502-P1410	2	14	0	0	142.4	ME2502-S38	2	0	0	38	237.6

Note: 1) N channels 10A rings parallel can be used as 1 channel N*10A current. For example: 2 rings 10A parallel could be used as 1 wires 20A

2) According to your own needs, 10A, 20A and 5A can be combined freely. Please contact customer service if you need over 2 channels Ethernet.

Product Quality Level Table

Products Level Code	Max Rotating Speed	Working Life	Contact Material
VC	150RPM	20 Million Revs	Precious Metal
VD	600RPM	80 Million Revs	Gold-plated

Lead Wires Color Code

Ring	1	2	3	4	5	6	7	8	9	10	11	12
Color	BLK	RED	YLW	GRN	BLU	WHT	BLK	RED	YLW	GRN	BLU	WHT

(6 wires for 1 group color, from 7-12, repeat the same color as 1...6, indicated with number code pipe)

Options for custom slip ring

Note: Below special demands can be customized. According, the delivery date will be extended 3 to 15 days; also the cost will be increased 30% to 50%. Most of our basic parts are standard and modular, which can save the cost and lead time.

- ① Bore diameter can be customized, cable exit way and cable length can be customized for both rotor and stator.
- ② Because of the structure limitation, length/height/OD can be customized on your request.
- ③ Support current or signal up to 200 rings.
- ④ Aviation plug, terminal and heat-shrink tube are optional.
- ⑤ Hybrid slip ring for Yaskawa/Panasonic/Siemens servo control signal, power line and encoder line.
- ⑥ Support mixed high speed data transmission (including Ethernet, USB, RS232, RS485, Profibus, CanBUS, CANOPEN, DeviceNET, CC-LINK, ProfiNET, EtherCAT, etc.)
- ⑦ Can combine temperature control signal with thermocouple signal.
- ⑧ Special environment can be customized, such as quakeproof, high temperature, etc.
- ⑨ Hybrid Pneumatic/hydraulic and electric slip ring can be mixed.
- ⑩ High temperature can up to 500 degrees.
- ⑪ High pressure can up to 110KV
- ⑫ Rotating speed can up to 10000RPM
- ⑬ Maximum current can up to 5000 amperes.
- ⑭ Military grade
- ⑮ Optional for underwater IP65, IP68.
- ⑯ Optional for stainless steel housing

Technical support: technical@moflon.com