

Industrial Spring Reels







CONDUCTIX
wampfler





Ⓞ DELACHAUX GROUP

Contents



Extension reels				
For compressed air and cold water				
 <p>TF1KP TF2KP TF3KP</p> <ul style="list-style-type: none"> - Plastic casing - Polyurethane hose 	 <p>TF3K</p> <ul style="list-style-type: none"> - Steel casing - SBR hose 	 <p>T02K T03K T04K</p> <ul style="list-style-type: none"> - Steel open reel - Polyurethane or SBR hose 	 <p>T05K T06K</p> <ul style="list-style-type: none"> - Steel open reel - Polyurethane or SBR hose 	 <p>T04K inox</p> <ul style="list-style-type: none"> - Stainless steel 316L - Antistatic hose
p.6		p.7		p.9

Extension reels			
For electric cables			
 <p>LF1KP LF2KP LF3KP</p> <ul style="list-style-type: none"> - H05VV-F cable - Core section up to 2.5 mm² 	 <p>LF3K</p> <ul style="list-style-type: none"> - H07RN-F cable - Core section up to 2.5 mm² 	 <p>L02K L03K</p> <ul style="list-style-type: none"> - H07RN-F cable - Core section up to 4 mm² 	 <p>L04K</p> <ul style="list-style-type: none"> - H07RN-F cable - Core section up to 6 mm²
p.10	p.11	p.12	p.13

Extension reels				
For grounding	For electric vehicles charging		For emergency response vehicles	
 <p>MT2K MT3K MF3K</p> <ul style="list-style-type: none"> - MALT cable - Core section up to 25 mm² 	 <p>M02K M03K M04K</p> <ul style="list-style-type: none"> - MALT cable - Core section up to 35 mm² 	 <p>L03K.X.VE</p> <ul style="list-style-type: none"> - Open steel reel - OLFLEX cable 	 <p>L03K/X</p> <ul style="list-style-type: none"> - Open steel reel - GPM cable 	 <p>RETTREEL</p> <ul style="list-style-type: none"> - Motorized open steel reel - H07RN-F or GPM-RF cable
p.14	p.15	p.16	p.17	p.18

Automatic reels		Manual rewind reels	Signalling reels
For electric cables		For cable and hose storage	
 <p>ESB</p> <ul style="list-style-type: none"> - C800 cable - Core section up to 3 mm² 	 <p>Cable C800</p> <ul style="list-style-type: none"> - Super-flexible cable, PVC sheath - Rated voltage 0.6/1 kV 	 <p>SR-Express</p> <ul style="list-style-type: none"> - Polyurethane cables - Core section up to 6 mm² 	 <p>MAP</p> <ul style="list-style-type: none"> - Completely steel made
p.19-20		p.21-24	p.25
			 <p>PN</p> <ul style="list-style-type: none"> - Steel casing - Water repellent banners
			p.26

Our products meet your expectations

A solution for each application

The spring reels in this catalog cover all the following industrial applications:

- Power or fluid supply to moving equipment and tools
- Battery charging for electric cars and ERV
- Protection against safety and security hazards due to electrostatic discharge and leakage currents
- Workstation-level support to industry and assembly workers
- Temporary marking and access prevention to dangerous areas in civil works, in plants, for maintenance operations

For demanding professionals

Our reels are reliable and sturdy, easy to install and to maintain. They are genuine industrial equipment designed to improve safety and work conditions in assembly, maintenance, car and trains repair shops, construction sites, airports...



Immediate improvements

- Enhance Safety at work: the risk of tripping and falling is reduced to a minimum as cables and hoses don't lay on the ground
- Reduce Maintenance costs: hoses and cables are coiled properly and protected from crunching and puncturing, their lifetime is increased
- Save space and time: the power tools are easily accessed and always ready to work
- Improve efficiency: our products are designed and built for very high reliability and utter safety



Extension reels

Supply energy to your hand power tools. Manual cable/hose extension reels with a ratchet system to hold the working position.



Automatic reels

Supply energy to all types of moving equipment. No manual operation required: unwinding and winding are fully automatic!



Manual rewind reels

Clean and compact storage for your cables and hoses. Mandatory for your 5S implementation!



Signalling reels

On construction sites, in workshops, around places accessible to the public, wherever a markup of security must be quickly operational!

Compliance

All our reels comply with the current European standards and bear our **CE** mark.

Availability

Most of our extension reels, manual rewind reels and signalling reels are available from stock and ship within 48 hours (TBC for volume order).

SR-Express automatic reels are built from standard components stock and shipped within 48h.

Packing and shipping

Our reels are packed individually in solid carton boxes. Depending on quantity, we group the cartons on wood pallets for shipment or ship the cartons individually.

Large size SR-Express and T05K/T06K reels are shipped in open wood crates.

Connections

On demand, we can equip our reels with plugs and connectors. Request our quotation!

Cables

We offer a large range of power, control, fiber optics and mixed cables, round and flat, designed especially for reeling applications and field proven.



Extension reel applications

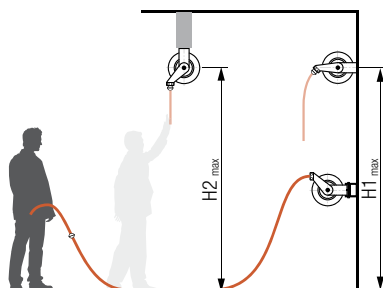

- Wall mounting: authorized for all extension reels w/ or w/o options up to $H1 = 2.5\text{ m}$
- Ceiling mounting: possible only for extension reels without swivel bracket and up to $H2 = 2.5\text{ m}$

Please consult us for other installations.

Automatic reel applications

- Retrieve application
- Reel installed on the moving machine
 - Cable laying on the ground

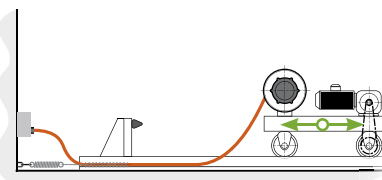

- Supported stretch application
- Reel installed on the moving machine
 - Cable supported (e.g. rollers)

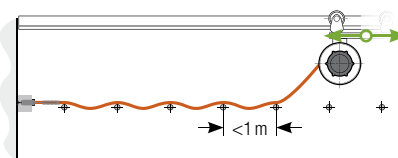

- Lift application
- Reel mounted stationary

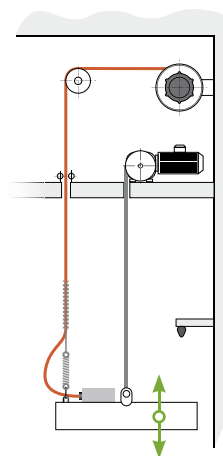

Extension reels for compressed air and cold water

TF1KP | TF2KP | TF3KP

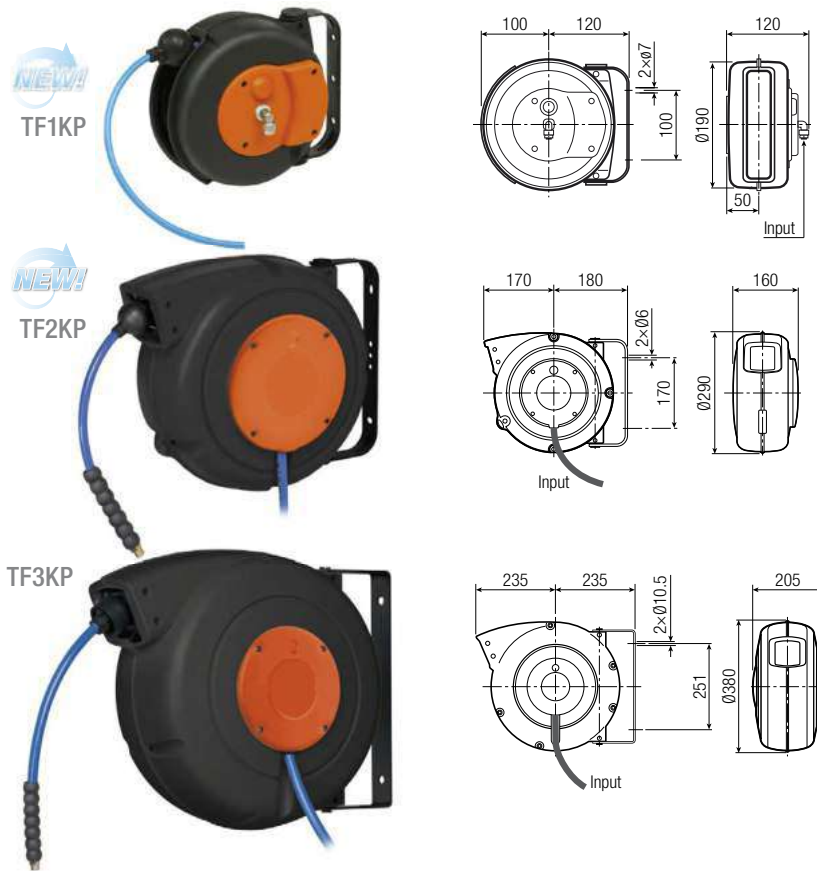

Technical details

- Impact-resistant plastic casing
- Steel swivel bracket
- Polyurethane hose
- Input hose 1.5m length
- Ratchet lock
- Adjustable hose stop
- Hose roller guide



TF1KP specifics

- Input hose fitting : quick connect
- Large fixed hose guide

Reels Order No.	Model	ID × OD	Hose		Fittings		Temperature [°C]	Weight [kg]	Dimensions L × l × H [cm]
			Total length [m]	Max. pressure [bar]	Input	Hose end			
3191054	TF1KP 060806 AC/EA	6 × 8	6.5	12	Ø6×8	1/4" M	-5 / +40	2.0	24 × 19.5 × 12
3191055	TF2KP 081210 AC/EA	8 × 12	10	15	hose 1.5 m w/o fitting	1/4" M	-5 / +50	4.0	34 × 34 × 16
3191056	TF3KP 101516 AC/EA	10 × 15	16			3/8" M		7.0	
3191057	TF3KP 121711 AC/EA	12.5 × 17	11			1/2" M		7.0	

TF3K

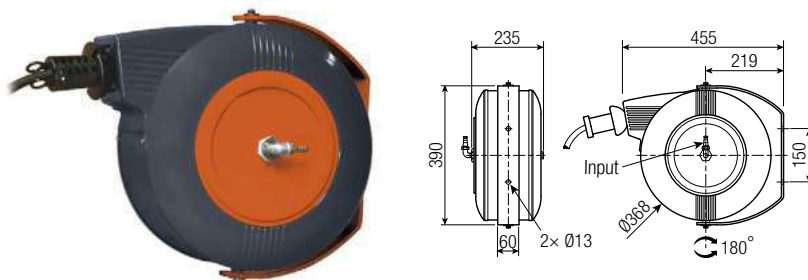

Technical details

- Steel casing, steel swivel bracket, epoxy paint finish
- SBR hose
- Ratchet lock
- Adjustable hose stop
- Hose roller guide
- Input: barbed hose fitting (not assembled, hose Inner Diameter in table below)



Reels Order No.	Model	ID × OD	Hose		Fittings		Temperature [°C]	Weight [kg]	Dimensions L × l × H [cm]
			Total length [m]	Max. pressure [bar]	Input	Hose end			
3192503	TF3K 071310 AC/EA	7 × 13	10	15	ID7	not supplied	-5 / +60	19	51 × 44 × 34
3192502	TF3K 071320 AC/EA	7 × 13	20		ID7			21	
3192505	TF3K 101710 AC/EA	10 × 17	10		ID10			20	

Extension reels for compressed air and cold water

T02K | T03K | T04K

T02K



SP2

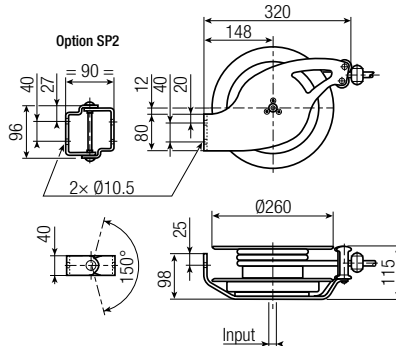

Technical details

- Steel drum, steel bracket, epoxy paint finish
- SBR Hose
- Ratchet lock
- Adjustable hose stop
- 3-position adjustable cable roller guide
- Input: barbed hose fitting (assembled, hose Inner Diameter in table below)



T03K



SP3

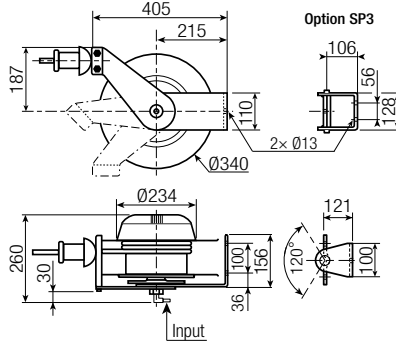

T02K specifics

- Polyurethane hose
- Hose roller guide
- Input: 3/8" female fitting

Options

- Swivel brackets SP

T04K



SP4

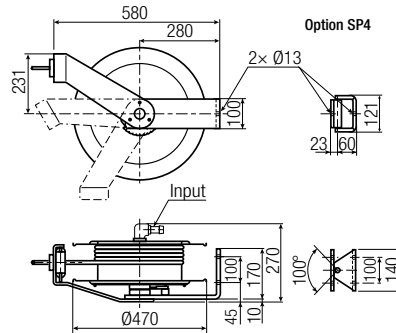

Reels		Hose			Fittings		Temperature			
Order No.	Model	ID × OD	Total length [m]	Max. pressure [bar]	Input	Hose end	[°C]	[kg]	L × l × H [cm]	
3192464	T02K 081312 AC/EA	8 × 13	12	20	3/8" F	not supplied	-5 / +40	7	36 × 35 × 25.5	
3192477	T03K 071320 AC/EA	7 × 13	20	15	ID7		16	48 × 41 × 41.5		
3192480	T03K 091610 AC/EA	9 × 16	10		ID9		16			
3192479	T03K 091615 AC/EA	9 × 16	15		ID9		17			
3192476	T03K 101715 AC/EA	10 × 17	15		ID10		17			
3192478	T03K 132110 AC/EA	13 × 21	10		ID13		17			
3139274	T04K 071330 AC/EA	7 × 13	30		ID7		25		62 × 62 × 41	
3192511	T04K 091625 AC/EA	9 × 16	25		ID9		25			
3192510	T04K 132120 AC/EA	13 × 21	20		ID13		26			
3139277	T04K 162610 AC/EA	16 × 26	10		ID16		25			
3139278	T04K 192910 AC/EA	19 × 29	10		ID19		25			
Options										
3192291	Swivel bracket SP2 for model 2K							1.7	11 × 10 × 6	
3187823	Swivel bracket SP3 for model 3K							2.5	20 × 15 × 10	
3187801	Swivel bracket SP4 for model 4K							4.0	20 × 15 × 10	

Extension reels for compressed air and cold water

T05K | T06K



Technical specifications

- Zinc plated steel drum
- Additional clear varnish protection
- Epoxy coated steel fixing bracket
- SBR hose
- Ratchet lock
- Adjustable hose stop
- Hose roller guide
- Input: barbed hose fitting (hose Inner Diameter in table below, ID > 19mm not assembled)



Options

- Swivel brackets SP

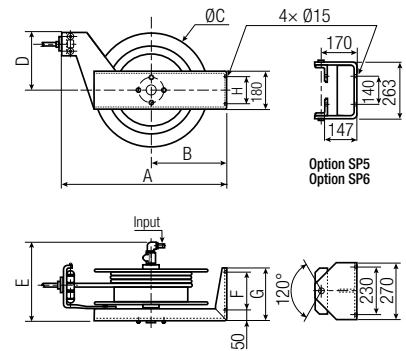

Model	A	B	ØC	D	E	F	G	H
T05K	770	360	540	275	385	180	250	130
T06K	870	405	630	340	435	200	300	140

Reels Order No.	Model	ID × OD	Hose		Fittings		Temperature [°C]	Temperature [kg]	L × l × H [cm]
			Total length [m]	Max. pressure [bar]	Input	Hose end			
3117753	T05K 091640 AC/EA	9 × 16	40	15	not supplied	-5 / +60	60	open wood crate	
3117754	T05K 101730 AC/EA	10 × 17	30						ID9
3117755	T05K 132130 AC/EA	13 × 21	30						ID10
3117758	T06K 132140 AC/EA	13 × 21	40						ID13
3117756	T05K 162620 AC/EA	16 × 26	20						ID13
3117759	T06K 162630 AC/EA	16 × 26	30						ID16
3117757	T05K 192915 AC/EA	19 × 29	15						ID16
3117760	T06K 192920 AC/EA	19 × 29	20						ID19
3117761	T06K 192925 AC/EA	19 × 29	25						ID19
3117762	T06K 253520 AC/EA	25 × 35	20						ID19
									ID25
Options									
3139458	Swivel bracket SP5 for model 5K							8.5	
3139456	Swivel bracket SP6 for model 6K							8.5	

Extension reels for compressed air and cold water

T04K/X inox



Technical details

- 316L stainless steel drum and swivel bracket
- Smooth surfaces, deburred (or rounded) edges
- Antistatic hose for breathing air
- For hoses ID10, ID13 and ID19mm
- Service pressure: max. 10 bar
- Ratchet lock
- Adjustable hose stop
- Hose roller guide
- Working temperature: -20°C/+60°C

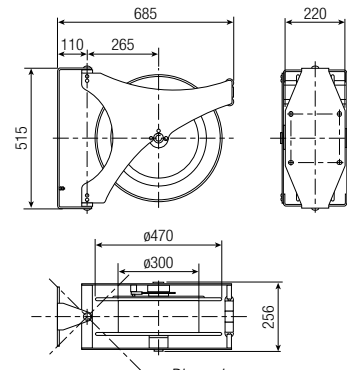

Dimensions are non committing

MAP/X inox | Manual rewind reel



Technical details

- 316L stainless steel drum and bracket
- Smooth surfaces, softened edges
- Antistatic hose for breathing air
- Fore hose ID13 (1/2")
- Service pressure: max. 10 bar
- Working temperature: -20°C /+60°C

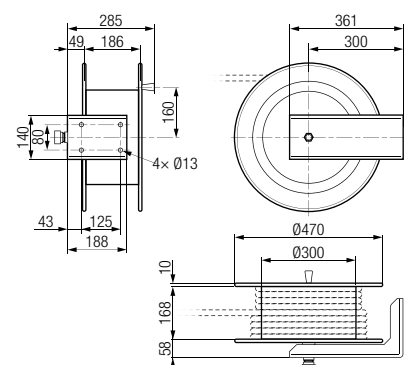

Dimensions are non committing

Extension reels for electric cables

LF1KP | LF2KP | LF3KP

NEW!
LF1KP

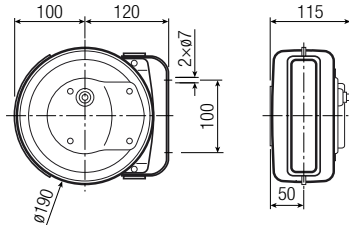

NEW!
LF2KP

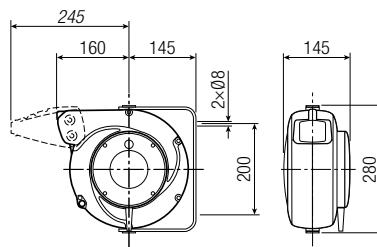

NEW!
LF3KP

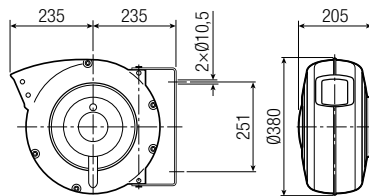

Technical details

- Impact-resistant, plastic casing
- Steel swivel bracket
- Thermal protection (depending on model)
- Ratchet lock
- Adjustable cable stop
- Cable roller guide (except LF1KP)
- Working temperature
-5°C / +50°C



Option

- Cable guide nozzle for model LF2KP ²⁾



Reels Order No.	Model	Cable		kW (20°C) ¹⁾		Max. Voltage AC/DC [V]	Thermal protection	⚖️ [kg]	📦 L x l x H [cm]
		No. of cores x S [mm ²]	Travel length [m]	⌚	⌚				
3191027	LF1KP 020107 VV	2 x 1	7.0	230V	1.1	1.6	•	3.0	24 x 19.5 x 12
3191028	LF1KP 031505 VV	3 G1.5	5.0		1.4	1.9			
3191030	LF2KP 030112 VV	3 G1	12.5	230V	0.9	1.4	•		
3191041	LF2KP 031510 VV	3 G1.5	10.0		1.2	1.8		•	
3191042	LF2KP 032507 VV	3 G2.5	7.0	400V	1.9	2.5	•		
3191043	LF2KP 041508 VV	4 G1.5	8.0		1.4	1.9			
3191044	LF2KP 042505 VV	4 G2.5	5.5	400V	2.0	2.7	•		
3191045	LF2KP 051505 VV	5 G1.5	5.5		1.4	1.9			
3191046	LF2KP 071506 VV	7 G1.5	5.5	400V	4.5 A		•		
3191047	LF2KP 080106 VV	8 G1	5.5		3.0 A				
3191049	LF3KP 031525 VV	3 G1.5	25.0	230V	1.1	1.8	•	9.0	43 x 40 x 21
3191051	LF3KP 032520 VV	3 G2.5	20.0		2.0	3.0			
3191052	LF3KP 051520 VV	5 G1.5	20.0	400V	1.5	2.2			
3191053	LF3KP 052515 VV	5 G2.5	15.0		2.0	3.0			

Option

3191048	Cable guide nozzle for model LF2KP ²⁾	Individual sachet
---------	--	-------------------

¹⁾ For 100% service duty applications or long periods in static operation: consult us.

²⁾ Optional cable guide nozzle increases IP to IP43

Extension reels for electric cables

LF3K



Technical details

- Steel casing, steel swivel bracket, epoxy paint finish
- Ratchet lock
- Adjustable cable stop
- Cable roller guide
- Input: 0.5 m long feeding cable

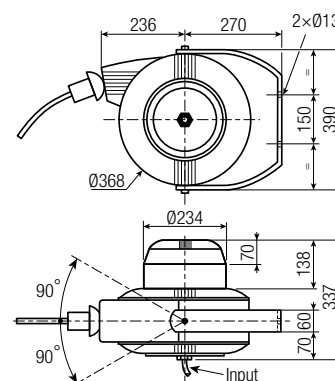

Reels Order No.	Model	Cable		Max amperage [A] ¹⁾		Max voltage AC/DC [V]	⏰ [kg]	📦 L x l x H [cm]
		No. of cores x S [mm ²]	Travel length [m]	⊙	⊚			
3139332	LF3K 031515 RN	3 G 1.5	15	16	22	400	23	56 x 46 x 42
3192483	LF3K 031520 RN		20				24	
3192484	LF3K 041515 RN	4 G 1.5	15				25	
3192485	LF3K 041520 RN		20				26	
3192486	LF3K 051518 RN	5 G 1.5	18	24	30		26	
3192488	LF3K 032516 RN	3 G 2.5	16				24	
3192489	LF3K 032520 RN		20				25	
3192490	LF3K 042515 RN	4 G 2.5	15				25	
3192501	LF3K 052513 RN	5 G 2.5	13			27		

¹⁾ For 100% service duty applications or long periods in static operation: consult us.

Extension reels for electric cables

L02K | L03K

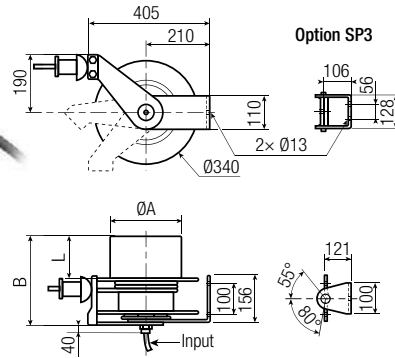
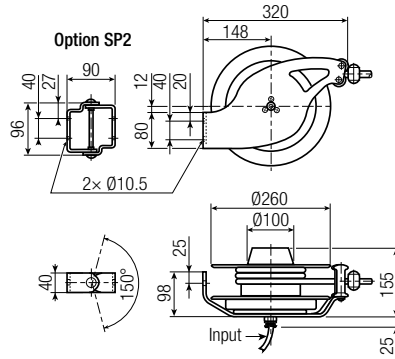

Technical details

- Steel drum, steel bracket, epoxy paint finish
- Ratchet lock
- Adjustable cable stop
- 3-position adjustable cable roller guide (fixed on L02K)
- Input: 0.5 m long feeding cable

Options

- Swivel brackets SP



Reels		Cable					Max amperage [A] ¹⁾		Max V AC/DC [V]	Weight [kg]	Dimensions L x l x H [cm]
Order No.	Model	ØA [mm]	B [mm]	L [mm]	No. of cores x S [mm ²]	Travel length [m]	⌚	⌚			
3192293	L02K 031512 RN	-	-	-	3 G 1.5	12	9	12	750	7.5	36 x 35 x 25
3192467	L03K 031516 RN	234	225	78		16	16	22	400	18	48 x 41 x 41.5
3192468	L03K 031520 RN					20			400	19	
3192295	L02K 041512 RN	-	-	-	4 G 1.5	12	9	12	750	8	36 x 35 x 25
3192469	L03K 041520 RN	234	225	78		20	16	22	400	20	48 x 41 x 41.5
3192463	L02K 051512 RN	-	-	-	5 G 1.5	12	9	12	750	8.5	36 x 35 x 25
3192470	L03K 051520 RN	234	225	78		20	16	22	400	20	48 x 41 x 41.5
3095725	L03K 071520 RN	220	285	140	7 G 1.5	20	9	12	750	22	48 x 41 x 41.5
3192294	L02K 032512 RN	-	-	-	3 G 2.5	12	13	16	750	8.5	36 x 35 x 25
3192471	L03K 032516 RN	234	225	78		16	24	30	400	19	48 x 41 x 41.5
3192472	L03K 032520 RN					20			400	20	
3192462	L02K 042510 RN	-	-	-	4 G 2.5	10	13	16	750	8.5	36 x 35 x 25
3192473	L03K 042516 RN	234	225	78		16	24	30	400	20	48 x 41 x 41.5
3192474	L03K 042520 RN					20			400	21	
3192475	L03K 052513 RN					13			400	20	
3139341	L03K 040415 RN	220	285	140	4 G 4	15	27	34	750	22	
Options											
3192291	Swivel bracket SP2 for model 2K								1.7	11 x 10 x 6	
3187823	Swivel bracket SP3 for model 3K								2.5	20 x 15 x 10	

¹⁾ For 100% service duty applications or long periods in static operation: consult us.

Extension reels for electric cables

L04K



SP4



Technical details

- Steel drum, steel bracket, epoxy paint finish
- Ratchet lock
- Adjustable cable stop
- 3-position adjustable cable roller guide



Options

- Other cable length on request
- Swivel bracket SP4

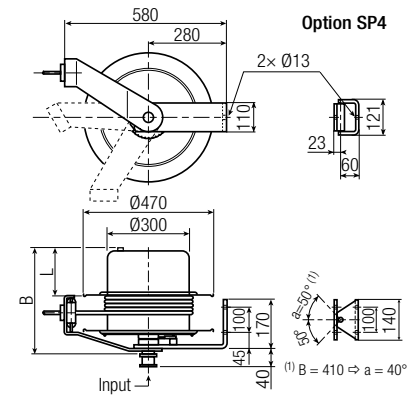

Reels		Cable				Max amperage [A] ¹⁾		Max voltage	⚖️ [kg]	📦 L × l × H [cm]	
Order No.	Model	B [mm]	L [mm]	No. of cores × S [mm ²]	Travel length [m]	⊙	⊚	AC/DC [V]			
3088407	L04K 051525 RN	345	125	5 G 1.5	25	16	22	500	27	62 × 62 × 41	
3139273	L04K 121515 RN	395	175	12 G 1.5	15	9	11		29		
3139292	L04K 032530 RN	345	125	3 G 2.5	30	19	24	750	32		
3192508	L04K 042525 RN			4 G 2.5	25	24	30		500		28
3094418	L04K 052520 RN			5 G 2.5	20	44	50	500	28		
3139344	L04K 052530 RN			5 G 2.5	30				19		24
3056750	L04K 050420 RN	395	175	5 G 4	20	34	40	30			
3139268	L04K 040615 RN	345	125	4 G 6	15	44	50	500	29		
3139269	L04K 050620 RN	395	175	5 G 6	20						

Option

3187801	Swivel bracket SP4 for model 4K	4	20 × 15 × 10
---------	---------------------------------	---	--------------

¹⁾ For 100% service duty applications or long periods in static operation: consult us.

Extension reels for grounding

MT2K | MT3K | MF3K



MT2K
MT3K



MF3K

Technical details

- Steel casing, steel swivel bracket, epoxy paint finish
- Insulating fixing washers
- Cable: single copper core, flexible cable with thick green/yellow PVC outer sheath
- Ratchet lock
- Adjustable cable stop
- Cable roller guide
- Equipped with a 'petroleum' 100A clamp according to NFN88070 (09/11/1972)



Accessories

- Self-opening safety clamp 100A

Option

- ATEX clamp to replace standard one (consult us)

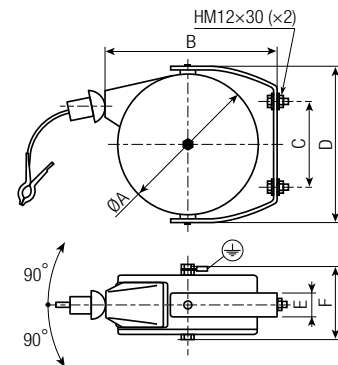

Model	ØA	B	C	D	E	F
MT2K	196	245	100	230	30	145
MT3K	303	368	220	340	40	184
MF3K	368	355	150	390	60	215

Reels Order No.	Model	Cable			⏰ [kg]	📦 L x l x H [cm]
		No. of cores x S [mm²]	Travel length [m]			
3193346	MT2K 010410 MA	1 x 4	10		10	24 x 24 x 26
3192944	MT3K 010415 MA	1 x 4	15		19	
3192945	MT3K 011012 MA	1 x 10	12		22	36 x 36 x 23
3192506	MF3K 011022 MA	1 x 10	22		25	
3192507	MF3K 012520 MA	1 x 25	20		25	56 x 46 x 42

Accessories | For models MTK - MFK - MOK

3138441	Clamp 100A Embossed brass
3138442	Safety clamp 100A Embossed brass For core section up to 10 mm²

Extension reels for grounding

M02K | M03K | M04K

M02K

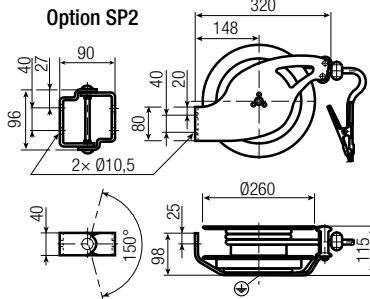

Technical details

- Steel drum, steel bracket, epoxy paint finish
- Insulating fixing washers
- Cable: single copper core, flexible cable with thick green/yellow PVC outer sheath
- Ratchet lock
- Adjustable cable stop
- 3-position adjustable cable roller guide (fixed on M02K)
- Equipped with a 'petroleum' clamp 100A according to NFN88070 (09/11/1972)



M03K

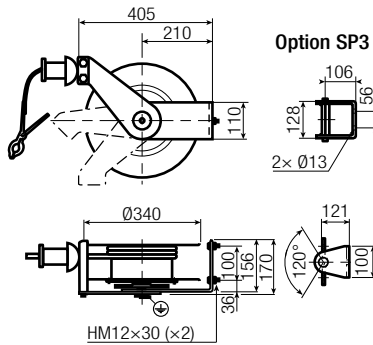

Accessories (see p.14)

- Self-opening safety clamp 100A

Options

- Swivel brackets SP
- ATEX clamp to replace standard one (consult us)

M04K

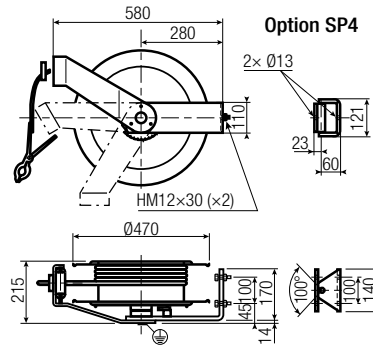

Reels		Cable		⚖️ [kg]	📦 L x l x H [cm]
Order No.	Model	No. of cores x S [mm²]	Travel length [m]		
3192465	M02K 010612 MA	1 x 6	12	7	36 x 35 x 25
3192481	M03K 011022 MA	1 x 10	22	12	51 x 44 x 34
3192514	M04K 011030 MA	1 x 10	30	25	62 x 62 x 41
3192482	M03K 012520 MA	1 x 25	20	17	51 x 44 x 34
3192994	M04K 012525 MA	1 x 25	25	18	62 x 62 x 41
3139310	M04K 012540 MA	1 x 25	40	30	62 x 62 x 41
3192513	M04K 013520 MA	1 x 35	20	30	62 x 62 x 41
Options					
3192291	Swivel bracket SP2 for model 2K			1.7	11 x 10 x 6
3187823	Swivel bracket SP3 for model 3K			2.5	20 x 15 x 10
3187801	Swivel bracket SP4 for model 4K			4	20 x 15 x 10

Extension reels for Electric Vehicles charging

L03K.X.VE



3 VERSIONS

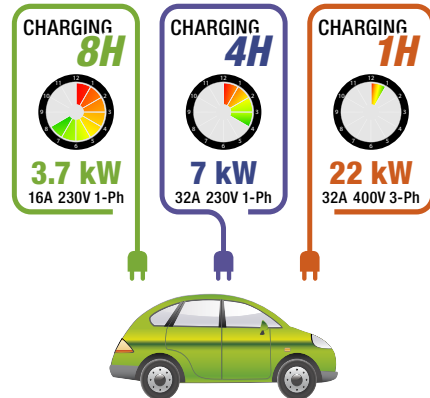

Application

- Extension spring reels for storage and protection of charging cable between the charger (station, wallbox) and the vehicle.
- Designed for Mode 3 charging according to IEC 62196-1

Technical details

- (A)** Female plug type T2 'Mennekes' with cap (vehicle connection)
- (B)** Male plug type T2 'Mennekes' (charger connection)
- Steel drum, steel bracket, epoxy paint finish
- Ratchet lock
- Adjustable cable stop
- 3-position adjustable cable roller guide
- Wall mounting

Options

- Swivel bracket SP3
- Supporting column

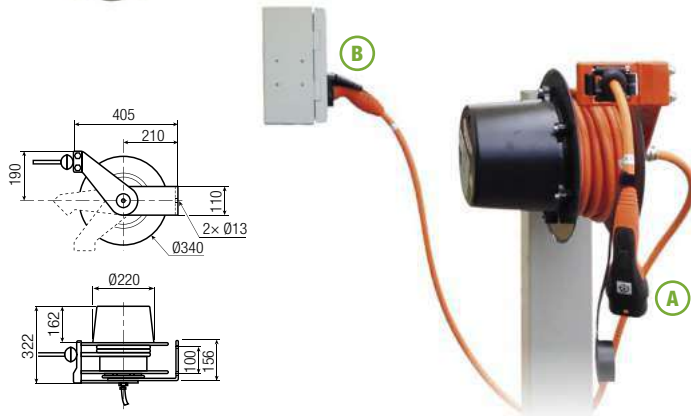

Reels			(A) Connection to the vehicle		(B) Connection to the charger			
Version	Order No.	Model	Cable	Length [m]	Cable	Length [m]	[kg]	L x l x H [cm]
3.7 kW - 16A	<i>Consult us</i>	L03K.X 032507.VE	OLFLEX	6.5	OLFLEX	1.5	17.5	47 x 40.5 x 43
		L03K.X 032510.VE	3G2.5mm ² +1x0.5mm ²	9.5	3G2.5mm ² +1x0.5mm ²		18.5	
7 kW - 32A	3189282	L03K.X 030607.VE	OLFLEX	6.5	OLFLEX	1.5	19.5	
	3188704	L03K.X 030610.VE	3G6mm ² +1x0.5mm ²	9.5	3G6mm ² +1x0.5mm ²		20.5	
22 kW - 32A	3189157	L03K.X 050607.VE	OLFLEX	6.5	OLFLEX	1.5	20.6	
	3188779	L03K.X 050610.VE	5G6mm ² +1x0.5mm ²	9.5	5G6mm ² +1x0.5mm ²		22.0	

Options			
Order No.	Description	[kg]	L x l x H [cm]
3187823	Swivel bracket SP3 for model 3K	2.5	20 x 15 x 10
3191935	Supporting column - <i>Consult us</i>		

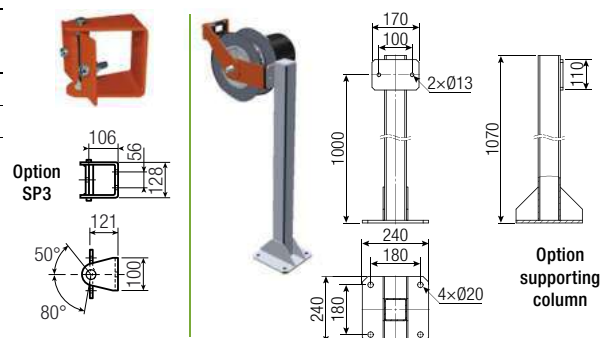

Extension reels for emergency response vehicles

L03K/X



Application

- Extension spring reel for the storage and protection of temporary auxiliary power cable for emergency vehicles when stationed in barracks.

Technical details

- Steel drum, steel bracket, epoxy paint finish
- Cable GPM 4G2.5 mm², polyurethane outer sheath
- Max. rated current: 15A (static use)
- Adjustable cable stop with impact absorber
- Cable end equipped with an immobilizer plug (depending on model)
- Ratchet lock

- 3-position adjustable cable roller guide
- Under-ceiling installation up to 5 m high
- Active travel lengths: 12 and 15 m

Options

- Swivel bracket SP3
- Slip ring type P050-25 A (*consult us*)

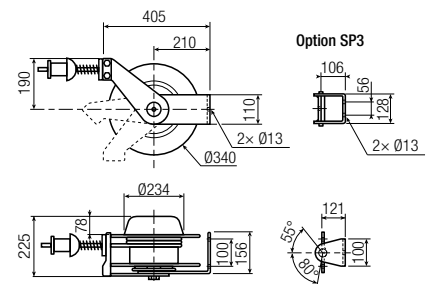

Reels		Cable		⚖️ [kg]	📦 L x l x H [cm]
Order No.	Model	Travel length [m]	No. of cores x S [mm ²]		
3169442	L03K/X 042512 w/ impact absorber cable stop	12	4 G2.5	20.5	48 x 41 x 41.5
3164926	L03K/X 042515 w/ impact absorber cable stop	15		21.5	
3171546	L03K/X 042512 w/ impact absorber cable stop & immobilizer plug	12		21.0	
3169911	L03K/X 042515 w/ impact absorber cable stop & immobilizer plug	15		22.0	
Option					
3187823	Swivel bracket SP3 for model 3K			2.5	20 x 15 x 10

MAP 206/X | Manual rewind reel



Technical details

- Equipped with 2 female sockets with cover 30 A - 230 V / 50 Hz
- IP55
- Steel drum and frame, red epoxy paint finish RAL 3020
- Cable: H07RN-F 3G2.5 mm² or 3G4 mm², 100 m long max

Option

- Cable end equipped with male plug 30 A - 230 V / 50 Hz - IP54



Extension reels for emergency response vehicles

RETTREEL

NEW!
CONSULT US



Application

- Motorized extension reel for the storage and protection of temporary auxiliary power cable for emergency vehicles when stationed in barracks.

Technical details

- Motorized reel powered and controlled by a wall box
- 230V single phase drive motor with cam limit switch (high / low adjustable stops)
- Steel drum and frame, polypropylene slip ring cover
- Epoxy paint finish
- Max. rated current: 20A (static use)
- Fixed cable roller guide
- Cable end equipped with an ejectable plug
- Reeling speed: 20 to 30 m/min
- Ceiling mounting up to 12 m high
- Active travel length: 10 m

Options

- Radio control
- Automatic ejection of the plug when the vehicle starts

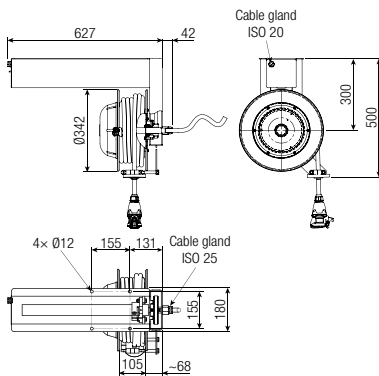

Model	Voltage	Plug configuration	Cables
PML3-20 12	12V-DC	2 Ph + 2 pilots	H07RN-F 5G 2.5 mm ²
		2 Ph + 2 aux. + 2 pilots	GPM-RF 7G 2.5 mm ²
PML3-20 24	24 V-DC	2 Ph + 2 pilots	H07RN-F 5G 2.5 mm ²
		2 Ph + 2 aux. + 2 pilots	GPM-RF 7G 2.5 mm ²
PML3-20 230	230V-AC	Ph + N + PE + 2 pilots	H07RN-F 5G 2.5 mm ²
		Ph + N + PE + 2 aux. + 2 pilots	GPM-RF 7G 2.5 mm ²
PML3-20 400	400V-AC	3 Ph + N + PE + 2 pilots	GPM-RF 7G 2.5 mm ²

PROCEDURE TO ↓	PRIOR SOLUTION SPRING REEL	RETTREEL SOLUTION MOTORIZED REEL
CONNECT THE VEHICLE TO THE POWER SOURCE	<ol style="list-style-type: none"> 1. Unwind the cable manually 2. Engage the ratchet 3. Connect the plug to the vehicle 	<ol style="list-style-type: none"> 1. Trigger the cable unwinding (descent of the plug) 2. Connect the plug to the vehicle
DISCONNECT THE VEHICLE FROM THE POWER SOURCE	<ol style="list-style-type: none"> 1. Disconnect the plug from the vehicle manually 2. Release the ratchet 3. Support the cable winding to its end 4. Start the engine (vehicle) 	<p style="text-align: center;">↔ OR ↔</p> <ol style="list-style-type: none"> 1. Disconnect the plug from the vehicle manually 2. Trigger automatic cable winding 3. Start the engine (vehicle) <p>* The ignition key automatically triggers:</p> <ul style="list-style-type: none"> - The ejection of the plug thanks to a built-in solenoid - The cable winding - The opening of the bar-rack gates (optional)

Automatic reels for electric cables

ESB

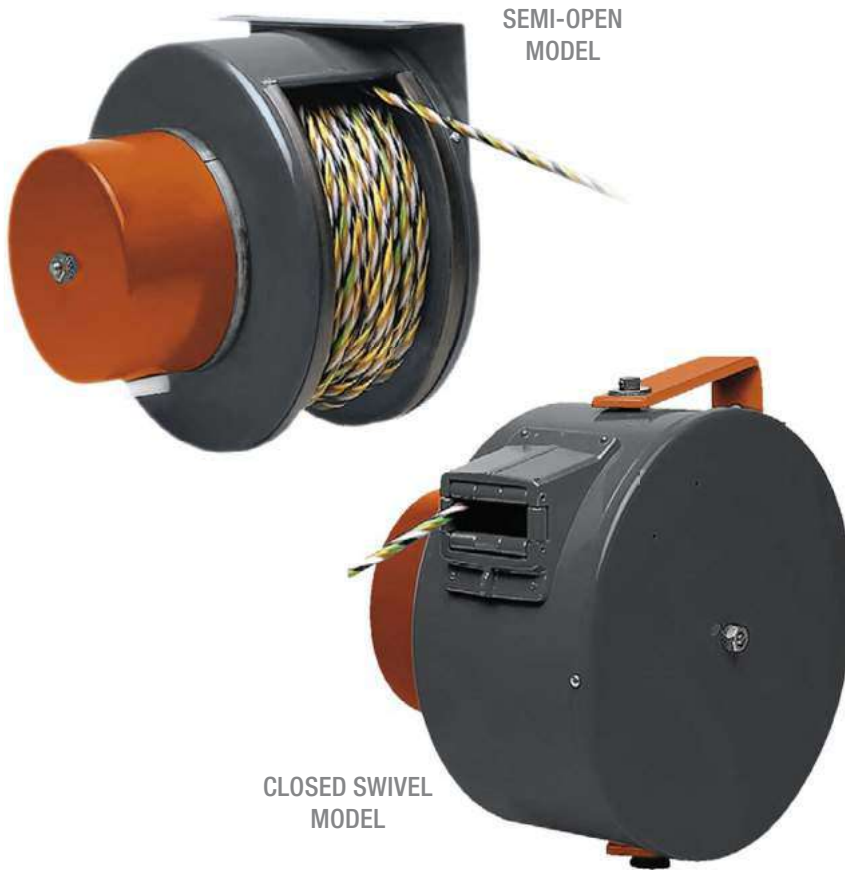

SEMI-OPEN MODEL

CLOSED SWIVEL MODEL

Technical details

- Steel casing, epoxy paint finish
- Steel swivel bracket, epoxy paint finish (closed model only)
- Super-flexible C800 cable
- Cable roller guide (closed model only)
- Slip rings
 - 20 EP: concentric circular tracks with double-piston side contact brushes
 - 20 EC | 30 EC: machined copper rings dia. 50 mm, high copper content brushes, and double brush holders



ESB | Closed swivel model

Model	A	ØB	C	D	E	F	G	H
20 EP 4	230	196	100	245	171	102	25	53
20 EC 3				310	236	167	105	
20 EC 6				310	290	221	160	
30 EC 3	348	303	232	368	275	184	110	88
30 EC 6				445	326	235	160	
30 EC 9				515	377	286	210	
30 EC 12				515	428	337	260	

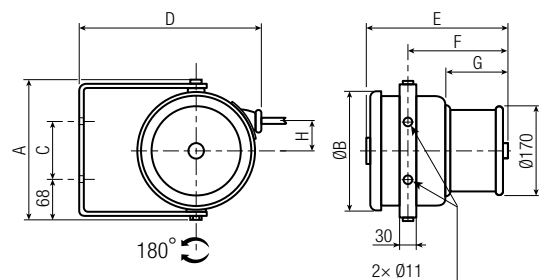

Reels Order No.	Model	Cable		Max amperage [A]		[kg]	L x l x H [cm]
		No. of cores x S [mm ²]	Travel length [m]	⊖	⊕		
3192951	20 EP 4 FP 040111 C8	4G1	11	5	5	7	24 x 24 x 25
3192952	20 EC 3 FP 040111 C8	4G1	11			8	
3192956	20 EC 6 FP 060107 C8	6G1	7			8	
3192946	30 EC 9 FP 100116 C8	10G1	16	10	10	19	42 x 42 x 46.5
3192957	30 EC 12 FP 120108 C8	12G1	8			19	
3192953	20 EC 3 FP 040208 C8	4G2	8			8	
3192954	30 EC 3 FP 040220 C8	4G2	20	15	15	19	48 x 41 x 41.5
3139227	30 EC 6 FP 060215 C8	6G2	15			19	
3192955	30 EC 3 FP 040314 C8	4G3	14			19	

Automatic reels for electric cables

ESB | Semi-open model

Model	A	B	C	D	E	F
20 EP 4	202	196	190	170	160	25
20 EC 3					236	110
20 EC 6					290	160
30 EC 3	307	303	270	210	275	110
30 EC 6					326	160
30 EC 9					377	210
30 EC 12					428	260

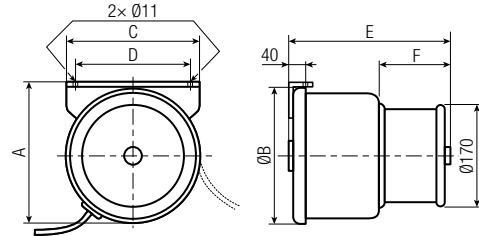

Reels Order No.	Model	Cable		Max amperage [A]		[kg]	L x l x H [cm]
		No. of cores x S [mm ²]	Travel length [m]	⊙	⊚		
3192959	20 EP 4 SO 040111 C8	4 G1	11	5	5	7	24 x 24 x 25
3192960	20 EC 6 SO 060111 C8	6 G1	11			8	
3139323	30 EC 9 SO 100120 C8	10 G1	20			19	42 x 42 x 46.5
3139381	30 EC 12 SO 120114 C8	12 G1	14	19			
3192963	20 EP 4 SO 040208 C8	4 G2	8	10	10	7	24 x 24 x 25
3192964	20 EC 3 SO 040210 C8	4 G2	10			8	
3192965	30 EC 3 SO 040224 C8	4 G2	24			19	32 x 31 x 25
3139376	30 EC 6 SO 060222 C8	6 G2	22			19	42 x 42 x 46.5
3139317	30 EC 3 SO 040320 C8	4 G3	20	15	15	19	

C800



Technical details

- Super-flexible multiconductor cable especially designed for reeling applications and machine wiring
- Short lay-length assembly to ensure high flexibility
- Clear PVC outer sheath including a tear-up yarn that makes sheath removing easier
- Supports high tensile loads
- Oil resistant
- Delivery: 50 or 100 meters long coil



Super flexible



0.6/1kV

Order No.	Number of cores x cross section [mm ²]	Outer diameter [mm]	Current carrying capacity max [A]	Permitted tensile load [kg]	[kg/m]
132250-R2X1#	2 x 1	5.7	5	4	0.046
132250-R3G1#	3 G1	6.0	5	6	0.059
132250-R4G1#	4 G1	6.8	5	8	0.075
132250-R6G1#	6 G1	8.0	5	12	0.110
132250-R8G1#	8 G1	9.7	5	16	0.157
132250-R10G1#	10 G1	10.6	5	20	0.181
132250-R12G1#	12 G1	12.2	5	24	0.232
132250-R15G1#	15 G1	12.9	5	24	0.260
132250-R3G2#	3 G2	7.1	10	12	0.093
132250-R4G2#	4 G2	8.0	10	16	0.120
132250-R5G2#	5 G2	8.7	10	20	0.149
132250-R6G2#	6 G2	9.8	10	24	0.181
132250-R4G3#	4 G3	10.4	15	24	0.199

Automatic reels for electric cables

SR-Express



SR-Express is a selection of spring cable reels from the global SR range defined to quickly and easily respond to the majority of industrial applications in energy supply for mobile devices.

The SR-Express reels are 'ready to use' with the cable installed and connected to the slip rings.

Application

- Energy and data supply to mobile industrial machineries such as overhead bridge cranes, gantries, mobile tables, aerial ladders and lifts, elevators, elevated work platforms, etc.
- **Neutral industrial environment**
- Indoor and outdoor use
- Ambient temperature range: -20 up to +60°C

Technical details

Cable drum

- Design to optimize cable arrangement during winding
- SR10 | SR20 | SR30: PA6-GF drum body, galvanized steel flanks
- SR40 | SR50: drum body and flanks made of zinc plated steel
- Lubricated for life, sealed ball bearings
- IP66 cable glands

Spring motor

- Springs made of high-performance textured steel to ensure a long service life: 100,000 spring solicitations
- SR40 | SR50: springs individually installed in cassettes for a safe and easy manipulation (replacement or reversal of winding direction)
- Springs lubricated with a corrosion resistant grease

Slip rings

- Slip rings located in a housing outside the cable drum for optimal access to connection
- Easy and reduced maintenance
- Impact-resistant, ABS-PC cover equipped with a breather to prevent condensation and with captive screws
- Protection IP65 to prevent dust and moisture entry into the slip ring housing

Slip ring	Amp. ¹⁾	Voltage max. ²⁾
B050	25 A	690 V-AC / 600 V-DC
D050	50 A	

Cables

- Halogen free, PUR cables specifically designed for reeling applications and providing excellent wear resistance and high flexibility



**Long service life
100 000 solicitations!**

Dimensions

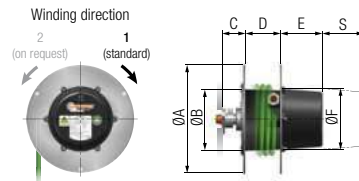

Model	ØA	ØB	C	D	ØF
SR10	320	170	73	114	220
SR20	400	220	86	129	220

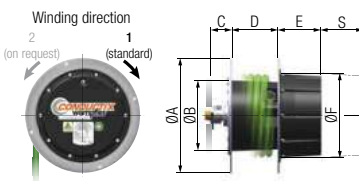

SR30	450	270	82	179	330
------	-----	-----	----	-----	-----

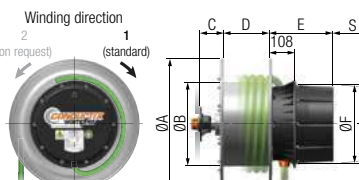

SR40	550	350	101	191	330
SR50	640	400	88	261	330

Dimensions according to slip ring type

Model	Slip ring	E	S ³⁾
SR10	4GB050	138	130
	7GB050	168	160
	4GD050	168	160
SR20	4GB050	138	130
	7GB050	168	160
	12GB050	218	210
SR30	4GD050	168	160
	4GB050	168	160
	7GB050	168	160
SR40	12GB050	218	210
	18GB050	322	315
	4GD050	168	160
SR50	7GB050	269	160
	12GB050	319	210
	18GB050	423	315
SR50	4GD050	269	160
SR50	18GB050	423	315

Mounting flanges

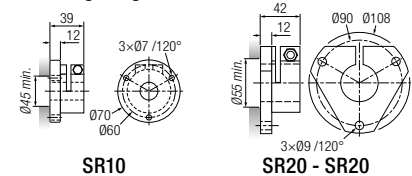

SR10

SR20 - SR20

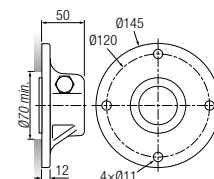

SR40 - SR50

¹⁾ Rated amperage @+30°C and 100% duty ²⁾ Altitude max. 2000m ³⁾ S: clearance required for slip ring cover removal

Automatic reels for electric cables

SR-Express | Retrieve application

- Reel mounted on the moving machine, cable laying on the ground or supported by rollers (max distance pitch 1 m)
- Max speed = 60 m/min | Max acceleration = 0.3 m/s² | Max height of reel axis above the ground = 1 m
- For other conditions, consult us.

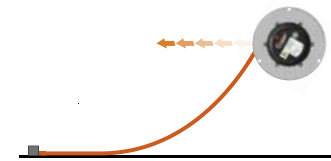

Cable Type	L ₀ [m]	L ₁ [m]	Reel		[kg]	[cm]	type	Cable grip Order No.	Spring impact absorber Order No.		
			Order No.	Model							
GPM 4G2.5mm ² OD 10.6 mm 0.17 kg/m	11	13	3183050	EXPRESS SR10.1SL.4GB050.042511.GPM	12.0	41 × 41 × 45	•	3057560	3057690		
	17	19	3183066	EXPRESS SR10.2SA.4GB050.042517.GPM	13.0	41 × 41 × 45	•				
	29	31	3183071	EXPRESS SR20.2SA.4GB050.042529.GPM	20.5	53 × 53 × 48	•				
	34	37	3183072	EXPRESS SR30.2SA.4GB050.042534.GPM	26.5	54 × 54 × 80	••				
	56	59	3183073	EXPRESS SR30.3SA.4GB050.042556.GPM	35.0	72 × 63 × 80	•••				
TXP 4G4mm ² OD 14.2 mm 0.24 kg/m	7	9	3210197	EXPRESS SR10.1SA.4GD050.040407.TXP	12.0	41 × 41 × 45	•	3056836	3057690		
	14	16	3210201	EXPRESS SR10.1SL.4GD050.040414.TXP	14.0	41 × 41 × 45	•				
	20	22	3211132	EXPRESS SR20.2SR.4GD050.040420.TXP	20.5	53 × 53 × 48	•				
	30	32	3210207	EXPRESS SR20.2SA.4GD050.040430.TXP	22.5	53 × 53 × 48	•				
	36	39	3211135	EXPRESS SR30.2SA.4GD050.040436.TXP	29.5	54 × 54 × 80	••				
TXP 4G6mm ² OD 15.7mm 0.33 kg/m	8	10	3210213	EXPRESS SR10.1SA.4GD050.040608.TXP	13.5	41 × 41 × 45	•	3056836	3057690		
	19	21	3211137	EXPRESS SR10.2SA.4GD050.040619.TXP	17.0	41 × 41 × 45	•				
	29	31	3210220	EXPRESS SR20.2SA.4GD050.040629.TXP	25.0	53 × 53 × 48	•				
	37	40	3210222	EXPRESS SR30.2SA.4GD050.040637.TXP	33.0	54 × 54 × 80	••				
	47	50	3210223	EXPRESS SR30.3SA.4GD050.040647.TXP	41.5	72 × 63 × 80	•••				
TXP 4G6mm ² OD 15.7mm 0.33 kg/m	54	58	3210224	EXPRESS SR40.2SA.4GD050.040654.TXP	69.0	72 × 63 × 80	•••	3056836	3057690		
	7	9	3183088	EXPRESS SR10.1SA.7GB050.071507.RXP	12.0	41 × 41 × 45	•			3057560	3057690
	15	17	3183089	EXPRESS SR10.2SA.7GB050.071515.RXP	13.5	41 × 41 × 45	•				
	22	24	3183090	EXPRESS SR20.2SR.7GB050.071522.RXP	20.5	53 × 53 × 48	•				
	30	32	3202410	EXPRESS SR20.2SA.7GB050.071530.RXP	22.0	53 × 53 × 48	•				
37	40	3183092	EXPRESS SR30.2SA.7GB050.071537.RXP	29.0	54 × 54 × 80	••					
RXP 7G1.5mm ² OD 12.8 mm 0.22 kg/m	54	57	3183093	EXPRESS SR30.3SA.7GB050.071554.RXP	37.5	72 × 63 × 80	•••	3057560	3057690		
	12	14	3202408	EXPRESS SR10.1SL.7GB050.072512.GPM-RF	14.0	41 × 41 × 45	•			3056836	3057690
	21	23	3183096	EXPRESS SR20.2SA.7GB050.072521.GPM-RF	21.5	53 × 53 × 48	•				
	28	30	3211072	EXPRESS SR20.2SA.7GB050.072528.GPM-RF	23.5	53 × 53 × 48	•				
	37	40	3183098	EXPRESS SR30.2SA.7GB050.072537.GPM-RF	31.0	54 × 54 × 80	••				
46	49	3211140	EXPRESS SR30.3SA.7GB050.072546.GPM-RF	38.5	72 × 63 × 80	•••					
GPM-RF 7G2.5mm ² OD 14.0 mm 0.28 kg/m	8	10	3183101	EXPRESS SR20.1SR.12GB050.121508.RXP	13.5	53 × 53 × 48	•	3056836	3057690		
	18	20	3183103	EXPRESS SR20.2SA.12GB050.121518.RXP	22.0	53 × 53 × 48	•				
	29	32	3183106	EXPRESS SR30.2SA.12GB050.121529.RXP	31.5	54 × 54 × 80	••				
	37	40	3183107	EXPRESS SR30.2SA.12GB050.121537.RXP	34.5	54 × 54 × 80	••				
	47	51	3211076	EXPRESS SR40.2SA.12GB050.121547.RXP	68.5	88 × 84 × 94	•••				
RXP 12G1.5mm ² OD 16.2 mm 0.36 kg/m	7	9	3183109	EXPRESS SR20.1SR.12GB050.122507.GPM-RF	13.5	53 × 53 × 48	•	3056836	3057690		
	18	20	3211077	EXPRESS SR20.2SR.12GB050.122518.GPM-RF	23.0	53 × 53 × 48	•				
	28	31	3183113	EXPRESS SR30.2SA.12GB050.122528.GPM-RF	32.5	54 × 54 × 80	••				
	37	41	3183114	EXPRESS SR40.2SA.12GB050.122537.GPM-RF	67.0	88 × 84 × 94	•••				
	47	51	3211143	EXPRESS SR40.2SA.12GB050.122547.GPM-RF	71.0	88 × 84 × 94	•••				
GPM-RF 12G2.5mm ² OD 16.3 mm 0.41 kg/m	10	13	3183116	EXPRESS SR30.1SR.18GB050.181510.RXP	26.0	54 × 54 × 80	••	3056836	3057690		
	22	25	3183118	EXPRESS SR30.2SA.18GB050.181522.RXP	31.5	54 × 54 × 80	••				
	28	31	3183060	EXPRESS SR30.2SA.18GB050.181528.RXP	34.5	54 × 54 × 80	••				
	37	41	3183161	EXPRESS SR40.2SA.18GB050.181537.RXP	74.0	88 × 84 × 94	•••				
	44	48	3183162	EXPRESS SR40.2SA.18GB050.181544.RXP	77.0	88 × 84 × 94	•••				
RXP 18G1.5mm ² OD 17.2 mm 0.46 kg/m	8	11	3211080	EXPRESS SR30.1SR.18GB050.182508.RXP	27.5	54 × 54 × 80	••	3057564	3057690		
	13	16	3210248	EXPRESS SR30.1SA.18GB050.182513.RXP	25.5	54 × 54 × 80	••				
	19	22	3210249	EXPRESS SR30.2SA.18GB050.182519.RXP	34.5	54 × 54 × 80	••				
	28	32	3210253	EXPRESS SR40.1SA.18GB050.182528.RXP	61.5	88 × 84 × 94	•••				
	37	42	3210254	EXPRESS SR50.2SA.18GB050.182537.RXP	88.0	88 × 84 × 94	•••				
RXP 18G2.5mm ² OD 19.8 mm 0.67 kg/m	47	52	3211145	EXPRESS SR50.2SA.18GB050.182547.RXP	95.0	88 × 84 × 94	•••	3057564	3057690		

- Cardboard box
- Cardboard pallet
- Open wooden crate

Automatic reels for electric cables

SR-Express | Lift application

- Reel mounted stationary, cable wound up vertically
- Max speed = 30 m/min | Max acceleration = 0.3 m/s²
- For other conditions, consult us.



Cable Type	L _u [m]	L _r [m]	Reel		[kg]	[cm]	type	Cable grip Order No.	Spring impact absorber Order No.
			Order No.	Model					
GPM 4G2.5mm ² OD 10.6 mm 0.17 kg/m	11	13	3183050	EXPRESS SR10.1SL.4GB050.042511.GPM	12.0	41 × 41 × 45	•	3057560 or 3057556 ¹⁾	3057690
	17	19	3183066	EXPRESS SR10.2SA.4GB050.042517.GPM	13.0	41 × 41 × 45	•		
	21	23	3183069	EXPRESS SR20.2SR.4GB050.042521.GPM	19.0	53 × 53 × 48	•		
	34	37	3203295	EXPRESS SR30.3SR.4GB050.042534.GPM	31.5	54 × 54 × 80	••		
TXP 4G4mm ² OD 14.2 mm 0.24 kg/m	7	9	3210197	EXPRESS SR10.1SA.4GD050.040407.TXP	12.0	41 × 41 × 45	•	3056836 or 3057556 ¹⁾	3057690
	12	14	3210199	EXPRESS SR10.2SA.4GD050.040412.TXP	13.5	41 × 41 × 45	•		
	20	22	3211132	EXPRESS SR20.2SR.4GD050.040420.TXP	20.5	53 × 53 × 48	•		
	29	32	3211134	EXPRESS SR30.2SR.4GD050.040429.TXP	27.5	54 × 54 × 80	••		
TXP 4G6mm ² OD 15.7mm 0.33 kg/m	8	10	3210213	EXPRESS SR10.1SA.4GD050.040608.TXP	13.5	41 × 41 × 45	•	3056836 or 3057598 ¹⁾	3057690
	14	16	3210215	EXPRESS SR20.2PA.4GD050.040614.TXP	20.5	53 × 53 × 48	•		
	18	21	3210217	EXPRESS SR30.2SR.4GD050.040618.TXP	27.0	54 × 54 × 80	••		
	26	29	3211138	EXPRESS SR30.2SR.4GD050.040626.TXP	29.5	54 × 54 × 80	••		
RXP 7G1.5mm ² OD 12.8 mm 0.22 kg/m	7	9	3183088	EXPRESS SR10.1SA.7GB050.071507.RXP	12.0	41 × 41 × 45	•	3057560 or 3057556 ¹⁾	3057690
	15	17	3183089	EXPRESS SR10.2SA.7GB050.071515.RXP	13.5	41 × 41 × 45	•		
	22	24	3183090	EXPRESS SR20.2SR.7GB050.071522.RXP	20.5	53 × 53 × 48	•		
	30	33	3183091	EXPRESS SR30.2SR.7GB050.071530.RXP	27.5	54 × 54 × 80	••		
GPM-RF 7G2.5mm ² OD 14.0 mm 0.28 kg/m	10	12	3211059	EXPRESS SR10.2SA.7GB050.072510.GPM-RF	13.5	41 × 41 × 45	•	3056836 or 3057556 ¹⁾	3057690
	14	16	3183095	EXPRESS SR20.2PA.7GB050.072514.GPM-RF	19.5	53 × 53 × 48	•		
	18	20	3211071	EXPRESS SR20.2SR.7GB050.072518.GPM-RF	20.5	53 × 53 × 48	•		
	27	30	3211139	EXPRESS SR30.2SR.7GB050.072527.GPM-RF	28.5	54 × 54 × 80	••		
RXP 12G1.5mm ² OD 16.2 mm 0.36 kg/m	8	10	3183101	EXPRESS SR20.1SR.12GB050.121508.RXP	13.5	53 × 53 × 48	•	3056836 or 3057598 ¹⁾	3057690
	15	17	3183102	EXPRESS SR20.2PA.12GB050.121515.RXP	21.0	53 × 53 × 48	•		
	21	24	3211074	EXPRESS SR30.2SR.12GB050.121521.RXP	28.5	54 × 54 × 80	••		
	26	30	3211142	EXPRESS SR40.1SA.12GB050.121526.RXP	66.0	88 × 84 × 94	•••		
GPM-RF 12G2.5mm ² OD 16.3 mm 0.41 kg/m	7	9	3183109	EXPRESS SR20.1SR.12GB050.122507.GPM-RF	18.5	53 × 53 × 48	•	3056836 or 3057598 ¹⁾	3057690
	17	20	3183110	EXPRESS SR30.2PA.12GB050.122517.GPM-RF	28.0	54 × 54 × 80	••		
	22	26	3211078	EXPRESS SR40.1SA.12GB050.122522.GPM-RF	50.5	88 × 84 × 94	•••		
	27	31	3183112	EXPRESS SR40.2PA.12GB050.122527.GPM-RF	67.5	88 × 84 × 94	•••		
RXP 18G1.5mm ² OD 17.2 mm 0.46 kg/m	10	13	3183116	EXPRESS SR30.1SR.18GB050.181510.RXP	26.0	54 × 54 × 80	••	3056836 or 3057598 ¹⁾	3057690
	16	19	3183117	EXPRESS SR30.2PA.18GB050.181516.RXP	28.5	54 × 54 × 80	••		
	20	24	3211079	EXPRESS SR40.1SA.18GB050.181520.RXP	51.0	88 × 84 × 94	•••		
	27	31	3183059	EXPRESS SR40.2PA.18GB050.181527.RXP	69.5	88 × 84 × 94	•••		
RXP 18G2.5mm ² OD 19.8 mm 0.67 kg/m	8	11	3211080	EXPRESS SR30.1SR.18GB050.182508.RXP	27.5	54 × 54 × 80	••	3057564 or 3057598 ¹⁾	3057690
	13	16	3210247	EXPRESS SR30.2PA.18GB050.182513.RXP	30.5	54 × 54 × 80	••		
	18	21	3210250	EXPRESS SR30.3PA.18GB050.182518.RXP	39.0	72 × 63 × 80	•••		
	23	27	3211081	EXPRESS SR40.2PA.18GB050.182523.RXP	73.0	88 × 84 × 94	•••		
	28	32	3210252	EXPRESS SR40.3PA.18GB050.182528.RXP	86.5	88 × 84 × 94	•••		

• Cardboard box •• Cardboard pallet ••• Open wooden crate

¹⁾ For high duty applications

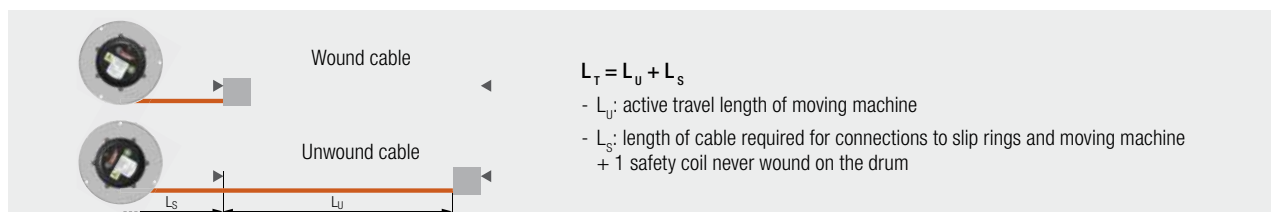

Automatic reels for electric cables

SR-Express | Options

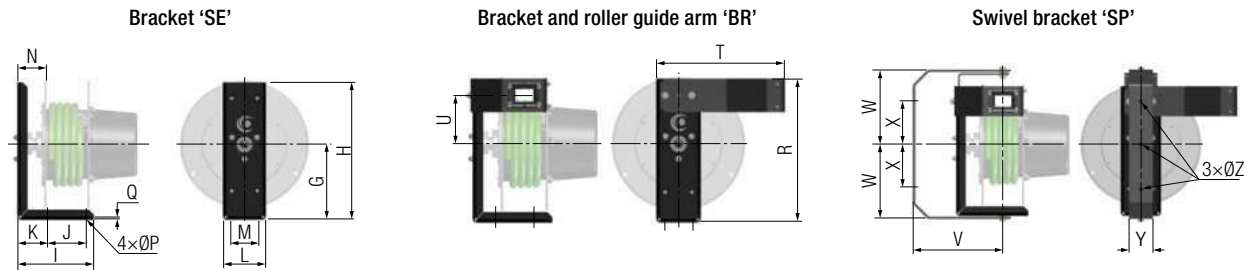

Model	G	H	I	J	K	L	M	N	ØP	Q	R	T	U	V	W	X	Y	ØZ
SR10	213	384	204	120	64	110	80	79	13	6	394	375	131	250	225	130	60	13
SR20	236	431	240	125	95	134	80	92	13	6	431	387	145	300	250	150	80	13
SR30	278	530	276	125	114	134	80	88	13	6	530	428	195	350	295	195	110	13
SR40	360	650	300	180	50	200	130	106	17	5	650	556	220	475	405	300	110	17
SR50	405	760	300	230	50	240	170	96	17	5	760	625	265	-	-	-	-	-

Order No.	Model	 [kg]
3171763	Bracket 'SE' for SR10	3.0
3171798	Bracket 'SE' for SR20	5.0
3172677	Bracket 'SE' for SR30	8.0
3171851	Bracket 'SE' for SR40	11.0
3171877	Bracket 'SE' for SR50	14.5
3171800	Bracket and roller guide arm 'BR' for SR10	5.5
3171835	Bracket and roller guide arm 'BR' for SR20	8.0
3172733	Bracket and roller guide arm 'BR' for SR30	11.5
3171872	Bracket and roller guide arm 'BR' for SR40	18.0
3182583	Bracket and roller guide arm 'BR' for SR50	23.0
3171791	Swivel bracket 'SP' for SR10	10.0
3172673	Swivel bracket 'SP' for SR20	15.0
3172691	Swivel bracket 'SP' for SR30	24.5
3173167	Swivel bracket 'SP' for SR40	38.5



Material: steel
Finish: black epoxy paint

Adapter flanges (option)

- Adapter flanges for installation in place of another type of spring reel: consult us.

SR-Express | Accessories

Cable grips and spring impact absorbers

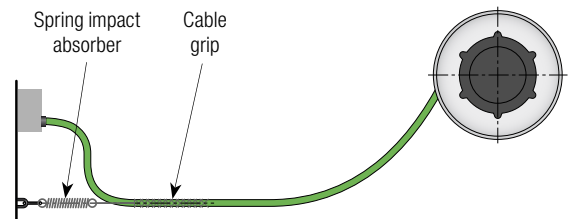

Order No.	Model	Cable OD	Use
3057560	Single-eye cable grip SB8	8 - 13 mm	All applications, normal duty
3056836	Single-eye cable grip SB13	13 - 18 mm	
3057564	Single-eye cable grip SB18	18 - 25 mm	
3057556	Double-eye cable grip DB8	8 - 15 mm	Lift applications, high duty
3057598	Double-eye cable grip DB15	15 - 25 mm	
3057690	Spring impact absorber 20 kg - cadmium plated steel		
3057692	Spring impact absorber 40 kg - cadmium plated steel		

Manual rewind reels for cable and hose storage

MAP 106 | MAP 206

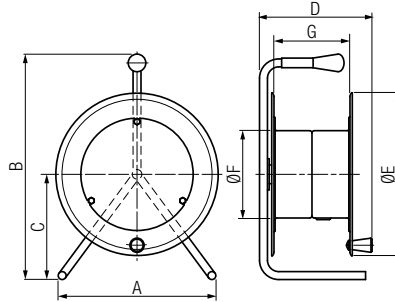

Model	A	B	C	D	ØE	ØF	G
MAP 106	280	400	185	200	288	155	130
MAP 206	340	535	240	255	442	204	175

Technical details

- Steel drum, epoxy paint finish
- Steel frame, epoxy paint finish
- Rubber handle
- Equipped with an undrilled flange closure
- Delivered without outlet



STEEL

Option

- Carrying trolley with two rubber wheels for MAP 206



Reels		Drum capacity [m] according to cable / hose outer diameter [mm]										[kg]	L x l x H [cm]
Order No.	Model	Ø5	Ø6	Ø7	Ø8	Ø10	Ø12	Ø14	Ø16	Ø18	Ø20		
3192968	MAP 106 w/o cable	185	125	95	75	40	25	-	-	-	-	4	40 x 30 x 22
3192969	MAP 206 w/o cable	600	435	330	235	160	105	80	55	40	38	9	55 x 45.5 x 27.5
Option													
3192970	Trolley for MAP 206											5	-

MAP 406 R | MAP 506 R

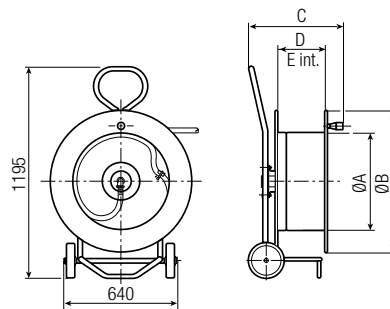

Model	ØA	ØB	C	D	E
MAP 406 R	350	600	411	156	196
MAP 506 R	550	800	530	260	310

Technical details

- Drum mounted on trolley with rubber tire wheels
- Tubular steel frame protected with epoxy paint
- Cold-formed steel sheet drum, hot dip galvanized
- Unwinding braking device
- Equipped with a ramp for attaching the cable or hose
- **Maximum load on drum: 60 kg**



STEEL

Max. load
60 kg

Reels		Drum capacity [m] according to cable / hose outer diameter [mm]										[kg]	
Order No.	Model	Ø10	Ø12	Ø14	Ø16	Ø18	Ø20	Ø22	Ø24	Ø26	Ø28		Ø30
3117657	MAP 406 R with rollers	265	180	135	100	70	60	45	45	28	26	24	33
3117659	MAP 506 R with rollers	630	400	310	230	170	150	110	95	65	65	60	43

Signalling reels

PN



Technical details

- Steel casing, epoxy paint finish
- Reel attachment: ring and 'S' hook
- Reel equipped with:
 - a steel rope with a handle at the end which can be hooked on when fully unwound
 - a water repellent banner composed of vertical red/white alternate bands

Option

- Banner reflectors (9 rectos - 9 versos)



Model	ØA	B	C	D
20 PN 12	193	210	53	145
20 PN 14	193	210	53	145
30 PN 16	303	312	88	184

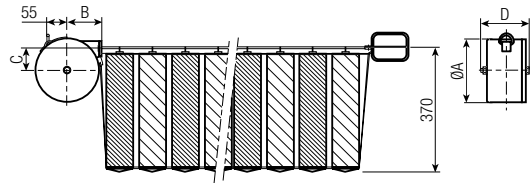

Reels			
Order No.	Model	[kg]	L x l x H [cm]
3192989	20 PN 12 with banner - L 12 m	7	24 x 24 x 25
3192990	20 PN 14 with banner - L 14 m	7.5	24 x 24 x 25
3192988	30 PN 16 with banner - L 16 m	16	36 x 36 x 23
3192991	20 PN 12 R with reflecting banner - L 12 m	7	24 x 24 x 25
3192992	20 PN 14 R with reflecting banner - L 14 m	7.5	24 x 24 x 25
3192981	30 PN 16 R with reflecting banner - L 16 m	16	36 x 36 x 23

Banners

Order No.	Model
3139084	Banner - L 12 m
3139085	Banner - L 14 m
3139086	Banner - L 16 m
3139081	Reflecting banner - L 12 m
3105771	Reflecting banner - L 14 m
3139083	Reflecting banner - L 16 m

Pit kits PN

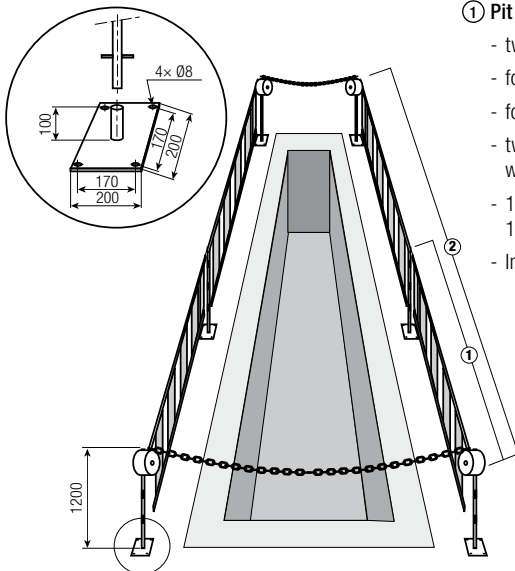

① Pit kit 14 m including:

- two 14 m retractable barrier reels
- four steel poles
- four fixing plates
- two 2.5 m lengths of red / white plastic chain
- 18 screws, 18 bushings, 18 washers
- Installation instructions

② Pit kit 28 m including:

- four 14 m retractable barrier reels
- six steel poles
- six fixing plates
- two 2.5 m lengths of red / white plastic chain
- 26 screws, 26 bushings, 26 washers
- Installation instructions



Pit kits

Order No.	Model
3139061	Pit kit - L 14 m
3139062	Pit kit - L 28 m

Your Applications - our Solutions

Industrial Spring Reels from Conductix-Wampfler represent only one of the many solutions made possible by the broad spectrum of Conductix-Wampfler components for the transport of energy, data and fluid media. The solutions we deliver for your applications are based on your specific requirements. In many cases, a combination of several different Conductix-Wampfler systems can prove advantageous. You can count on all of Conductix-Wampfler's Business Units for hands-on engineering support – coupled with the perfect solution to meet your energy management and control needs.



Festoon systems

It's hard to imagine Conductix-Wampfler cable trolleys not being used in virtually every industrial application. They're reliable and robust and available in an enormous variety of dimensions and designs.



Conductor rails

Whether they're enclosed conductor rails or expandable single-pole systems, the proven conductor rails by Conductix-Wampfler reliably move people and material.



Non-insulated conductor rails

Extremely robust, non-insulated conductor rails with copper heads or stainless steel surfaces provide the ideal basis for rough applications, for example in steel mills or shipyards.



Slip ring assemblies

Whenever things are really "moving in circles", the proven slip ring assemblies by Conductix-Wampfler ensure the flawless transfer of energy and data. Here, everything revolves around flexibility and reliability!



Motorized Cable & Hose Reels

Motorized reels by Conductix-Wampfler hold their own wherever energy, data, media and fluids have to cover the most diverse distances within a short amount of time - in all directions, fast and safe.



Spring Cable & Hose Reels

With their robust and efficient design Spring Cable and Hose Reels from Conductix-Wampfler are unbeatably reliable in supplying energy, signals, data and fluids to a vast range of tools, cranes and vehicles.



Inductive Power Transfer IPT®

The no-contact system for transferring energy and data. For all tasks that depend on high speeds and absolute resistance to wear.



Retractors and Balancers

Our wide range of high reliable retractors and balancers remove the load from your shoulders and allow you to reach top productivity.



Energy guiding chains

The "Jack of all trades" when it comes to transferring energy, data, air and fluid hoses. With their wide range, these energy guiding chains are the ideal solution for many industrial applications.



Jib booms

Complete with tool transporters, reels, or an entire media supply system – here, safety and flexibility are key to the completion of difficult tasks.



Conveyor systems

Whether manual, semiautomatic or with Power & Free – flexibility is achieved with full customization concerning layout and location.

www.conductix.com

Conductix-Wampfler

has just one critical mission:
to provide you with energy and
data transmission systems that
will keep your operations up and
running 24/7/365.

To contact your nearest sales
office, please refer to:

**[www.conductix.com/
contact-search](http://www.conductix.com/contact-search)**

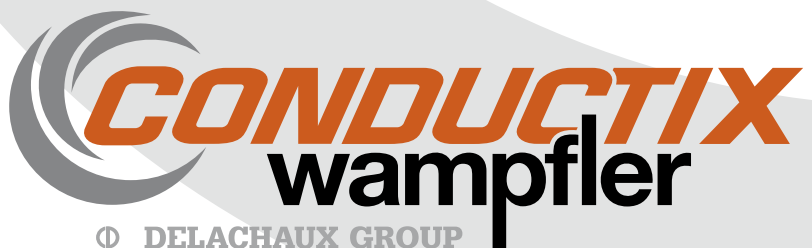

Ⓞ DELACHAUX GROUP